

ANNUAL REPORT

**2012
2013**



ANNUAL REPORT 2012 2013



Fraunhofer Institute for
Ceramic Technologies and Systems IKTS

Dresden branch of the institute
Winterbergstrasse 28, 01277 Dresden, Germany
Phone +49 351 2553-7700
Fax +49 351 2553-7600

Hermsdorf branch of the institute
Michael-Faraday-Strasse 1, 07629 Hermsdorf, Germany
Phone +49 36601 9301-0
Fax +49 36601 9301-3921

info@ikts.fraunhofer.de
www.ikts.fraunhofer.de

FOREWORD



Dear friends of IKTS,

We are glad to present you this year's annual report. We look back on an exciting and successful year again. We are pleased that we were able to increase our industrial revenues by 0.7 million euros to 12.6 million euros as compared to last year. This once again confirms that we are well positioned to fulfill our mission "research and development for the industry". Furthermore, we invested in our equipment and laboratory infrastructure to a great extent in order to better fulfill this task in future. Thus, our total operating budget has significantly grown by 4.6 million to 38.9 million euros. We could also strengthen our human resources and now are a team of 523 employees at our both branches.

We are glad that this positive development extended across all research fields. This confirms our strategy to broadly cover the field of ceramics and to give equal priority to structural as well as functional ceramics. In this connection, I would like to mention the membrane technology for liquid filtration and gas separation which belongs to the field of environmental technology and experienced particularly high growth. In order to come up with the increasing importance of the field of "environmental and engineering technology" we have established a department structure that reflects this growth. In all research fields we work along the entire value chain – from ceramic materials to systems including the manufacturing technologies as well.

As already mentioned last year, we have established a pilot plant for the development of production lines and processes for Li-ion batteries in cooperation with ThyssenKrupp System Engineering GmbH in Pleiße. On August 22, 2012, we officially opened the pilot plant in the presence of our Minister President Stanislaw Tillich. So, we were able to significantly expand our competencies in the field of electrochemistry and

storage technology. We give our special thanks to the Saxon Ministry for Science and the Arts (SMWK) and the central development agency Sächsische Aufbaubank (SAB) for supporting these activities. For a successful "energy transition" we consider the further development of storage technology as essential, since the disadvantage – that many renewable energies (wind, sun) cannot provide base load power – can only be overcome when energy storage devices are included. For this purpose, energy storage devices of different performance classes from kW to TW are required. Ceramic materials play a decisive role in all these fields so that our strategic focus is on these developments. For decentral, stationary small storage devices, we put emphasis on battery technology (Li-ion batteries, Na-based high-temperature batteries, redox-flow batteries). For energy storage in the TW-hour range, we rely on the so-called "power to gas" technology by means of which, e.g., excess wind energy can be converted into liquid fuels or

The Fraunhofer IKTS as a "one-stop shop" for ceramics

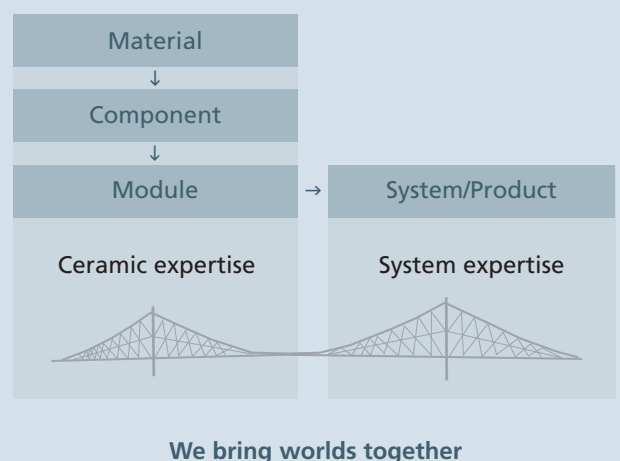



gas (wind gas) via hydrogen. So, the existing natural gas grid becomes an effective distribution and storage system. Prerequisite is an efficient hydrogen production. For this purpose, we develop fuel cells operated in electrolysis mode. Our membrane technology also plays an important role in this field so that we can make use of our competencies in a best possible manner.

In order to further expand these activities, we established the "GreenTech Campus" with support of the Thuringian Ministry of Economics, Employment and Technology (TMWAT) and the Thuringian Ministry of Education, Science and Arts (TMBWK). Here, our high-temperature batteries and membranes, in particular, are to be further developed and industry partners are to be settled. Further establishment of this campus will occupy our attention in the running year.

As special highlight of the previous year, I would like to mention our joint venture "Fuel Cell Energy Solutions GmbH" (FCES) with Fuel Cell Energy, Inc. (FCE) situated in Connecticut. Joining this joint venture, we have expanded our world leading competence in the field of solid oxide fuel cells (SOFC) to molten carbonate fuel cells (MCFC), and now, we are also able to provide fuel cell systems in the MW range. These fuel cells can achieve up to 90 % efficiency when configured to use the high-quality heat generated by the power plant in a combined heat and power (CHP) mode. These plants are suited to be powered by both natural gas and biogas. Power generation is virtually emission-free. Worldwide over 300 MW of power generation capacity have already been installed. Together with FCES GmbH we want to serve the European market and develop the next generation of MCFC systems. This example also shows that we consistently expanded our competence in the field of "energy and environmental technology".

As you can read in this annual report, we are not limited to this research field at all as we also work in the fields of tool development, mechanical engineering, automotive engineering, medicine and biotechnology, electronics and electric engineering, sensing and actuating systems, etc. In short, we stay a centipede in the field of ceramics and we are looking forward to further cooperation with you, everywhere, where ceramic materials and technologies play an important role. We would like to contribute our competencies to your projects, and we are open to new topics.

Enjoy reading this annual report!

Yours,

Alexander Michaelis

March 2013

TABLE OF CONTENTS

2 Foreword

4 Table of contents

Fraunhofer IKTS profile

6 Brief portrait

8 Fraunhofer IKTS in figures

11 Organizational chart

14 Board of trustees

15 The Fraunhofer-Gesellschaft

Retrospective

16 Events and awards

23 Participation in trade fairs

Research activities at Fraunhofer IKTS

26 **Research field: Materials**

28 MgO – Transparent ceramics with high thermal conductivity

30 Sintering of tungsten carbide ceramics

32 A ceramic foaming technology for high-temperature insulation materials

34 Metal-covered pellets – material composites for heat storage

36 Synthesis and characterization of rare earth-doped phosphors

38 **Research field: Processes and Components**

40 Ceramic matrix composites by injection molding of SiCN precursors

42 Conductive glass-carbon composites

44 Powder injection molding of translucent alumina

Research field: Environmental and Process Engineering

46 **Nanoporous Membranes**

48 Mixed matrix membranes

50 **High-Temperature Separation and Catalysis**

52 Thin asymmetric perovskite membranes for O₂ separation

54 **Biomass Technologies and Membrane Process Technology**

56 Biogas production from lignocellulosic residues

58 Practical evaluation and optimization of mixing processes

60 Membrane area and process optimized ceramic nanofiltration membranes

62	Chemical Engineering and Electrochemistry
64	Catalyst and reactor development for high-temperature catalysis
66	Research field: Sintering and Characterization
68	Hybrid heated FAST/SPS plant – Direct electrical and inductive
70	REACH – New requirements for the analysis of powders and suspensions
72	Wireless energy transfer for actuating and sensing technology
	Research field: Energy Systems
74	Materials and Components
76	Long-term stable electrodes for SOFC/SOEC operation
78	Metallization of nitride ceramics by active metal brazing
80	System Integration and Technology Transfer
82	Efficient combined heat and power applications in the MW power class
84	eneramic® – State of development and prototype testing of SOFC system
	Research field: Smart Microsystems
86	Smart Materials and Systems
88	Oxide targets for integrated thin films
90	Coating of 3D carbon fiber textiles by CVD and ALD
92	Hybrid Microsystems
94	Lead-free PV pastes with optimized rheology and contact formation
96	Force measurement by using the deformation of 3D structured ceramic bodies
98	Ceramic electronic packaging and systems integration
100	Integration of functional materials into ceramic multilayer packages
102	Subject area: Battery Technology
104	Spatially resolved in-operando temperature measurement
106	Thermal 3D modeling of lithium-ion cells
108	Material and slurry development for lithium-ion batteries
110	Electrode manufacturing for lithium-ion batteries on pilot scale
112	Ceramic materials for stationary electrical energy storage

114	Cooperation in groups, alliances and networks

119	Names, dates, events

145	Events and trade fairs 2013
147	How to reach us

BRIEF PORTRAIT

The work of the Fraunhofer Institute for Ceramic Technologies and Systems IKTS covers all aspects of technical ceramics from preliminary basic research to application. More than 140 well-equipped laboratories and pilot-scale facilities on nearly 20,000 square meters of usable floor space at the two locations Dresden and Hermsdorf are available for this. At Fraunhofer IKTS, high-performance ceramics know-how forms the basis of development work spanning the entire value chain up to prototype manufacturing. With threefold expertise – in materials know-how, production technologies, and system/product integration – chemists, physicists, and materials scientists are supported by experienced research engineers and technicians in activities focused equally on structural and functional ceramics technology platforms.

Project partners are found among both manufacturers and users of ceramics. With extensive expertise and numerous contacts, Fraunhofer IKTS serves as a “one-stop shop” for all ceramics-related problems. Our mission is to bring together different technology worlds to give our customers access to the entire range of innovative solutions provided by ceramics. Fraunhofer IKTS possesses a number of unique capabilities:

Complete production lines from material to prototype

All standard processes for mix preparation, shaping, heat treatment, and finishing of structural and functional ceramics are available. A key area of expertise in functional ceramics is paste and film technology. We manufacture functional ceramic prototypes using the hybrid and multilayer ceramics lines in our in-house clean rooms.

Multiscale development

Developments can be scaled up from laboratory to pilot scale. In our technological production chains, we can manufacture the quantities required for market introduction. Thus, we can minimize retention cost risks and time to market.

Synergies between structural and functional ceramics

By combining different technology platforms, we enable innovative ceramic products with extended functions and considerable added value to be manufactured.



Network formers

We are currently collaborating in projects with more than 450 national and international partners. Fraunhofer IKTS is also active in numerous networks and alliances, within the Fraunhofer-Gesellschaft, for example, in the Fraunhofer Group for Materials and Components – MATERIALS.

In addition, the role of spokesperson for the Fraunhofer AdvanCer Alliance, made up of seven institutes specialized in ceramics, is held by Fraunhofer IKTS. We facilitate network formation to drive product development and obtain the necessary external expertise.

This pioneering work is made possible by a wealth of experience, extensive knowledge, and constant focus on the interests of our partners.

Sustainable quality assurance management in both institute branches

For us, quality is one of the most important factors to stand out from the competition. For this reason, we merged the management systems of both institute branches in 2011. Due to the resulting synergy effects and cost savings we are now able to expand our management system to the fields of work safety and environmental protection.

Fraunhofer IKTS has already introduced and successfully established this environmental management system in Hermsdorf.

As the main focus of our research lies in the field of energy and environmental technologies, we implemented a sustainable environmental management system in Dresden in 2012, which is in accordance with DIN EN ISO 14001. This system guarantees that our processes comply to work safety and environmental standards as well as legal conditions and regulations while maintaining our competitiveness.

FRAUNHOFER IKTS IN FIGURES

Operating budget and revenues

The operating budget of Fraunhofer IKTS has increased by approx. 3 million euros to a total of 35.5 million euros: 24.9 million euros fall to the Dresden branch, and 10.6 million euros to the Hermsdorf branch. Here, we have achieved synergies by connecting both branches. Furthermore, 3.4 million euros were invested in equipment. Therefore, the total operating budget amounts to 38.9 million euros. Additionally, extensive building works have been carried out in both branches.

In total, we have earned 27.6 million euros in external funds. We are delighted to report that we were able to increase the industry revenues to 12.6 million euros. This corresponds to a share of 45.6 % of external funds. The Hermsdorf branch contributed to this success with revenues of 4.6 million euros that, once again, have been increased. With industry revenues of 8 million euros, Dresden has achieved the absolute results of last year.

A significant part of the growth is due to the acquisition of publicly funded projects, projects funded by the Fraunhofer Future Foundation and internal projects of the Fraunhofer-Gesellschaft. This preliminary research will then again result in increased industry revenues in the coming years. The revenues

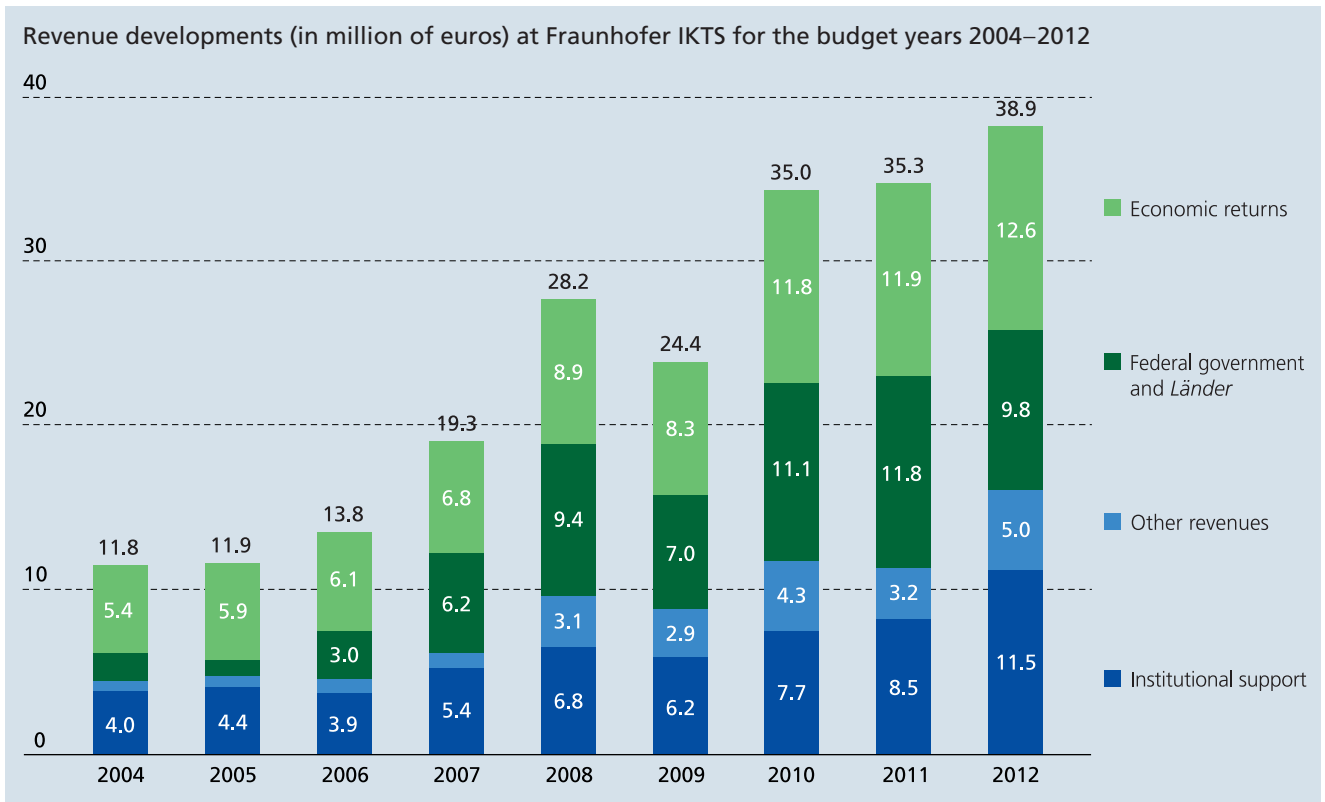

from EU projects have already been increased from 1 % to 3.3 %. For the first time, we have earned more than one million euros through EU projects.

Personnel development

Last year was marked by an increase of staff. We created 7 new jobs for scientists and 10 jobs for graduates and technicians. In total, we have 438 full-time positions with 377 employees in Dresden and 146 employees in Hermsdorf. Many of our student workers stay on at Fraunhofer IKTS to write their doctoral thesis.

The cooperation with the chair of IfWW, Institute for Material Science at TU Dresden, continues to be an essential part of our personnel recruitment. Currently, 60 doctoral theses are being supervised.

Technical training has also been strengthened at Fraunhofer IKTS. In 2011, the number of apprentices has been increased by 3 to 16. Due to the age structure at the institute, there are good options for the apprentices to get employed at Fraunhofer IKTS after their apprentice.

Expansion of the research basis

In 2012, Fraunhofer IKTS once again benefited from the large investments of the last years which were made in the field of "System Research Energy Efficiency". Additionally, research on structural ceramics has been further expanded. The research field of "High-Purity Oxide Ceramics" continues to be established as a strategic key technology. Here, further efforts will be made to broaden the scientific basis.

Personnel developments at Fraunhofer IKTS
Number of employees 2007–2012, full-time equivalents
Personnel structure on December 31 of each year

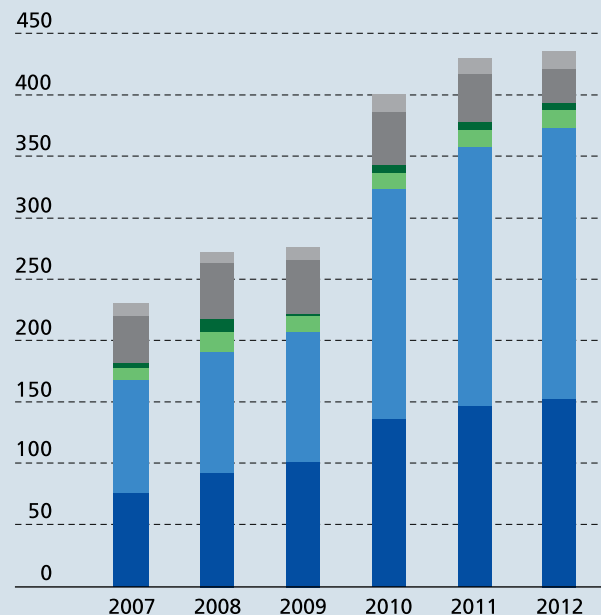

	10	8	9	15	13	16
	38	47	45	43	40	27
	4	10	2	6	6	5
	9	17	13	13	14	15
	92	97	106	187	211	221
	77	94	101	137	147	154
=	230	273	276	401	431	438

- Apprentices
- Student workers, trainees, undergraduate students
- Part-time and contract workers
- Doctorate students
- Employees with university degrees and technicians
- Scientists



The strategic activities in the field of ceramic injection molding have been further strengthened in 2012. Special emphasis will be placed on the combination of tape casting and injection molding technology. Our industry cooperation with Thyssen-Krupp System Engineering GmbH in the field of Li-ion batteries and the opening of the Bioenergy Application Center Pöhl in collaboration with Lehmann Maschinenbau GmbH have been successfully accomplished which will ensure future research activities.

In 2012, the concept of a joint Center of Energy and Environmental Chemistry (CEEC), which was developed in cooperation with the Friedrich Schiller University Jena, has further been driven forward. The idea is to pool the material scientific as well as system and processing-relevant competencies of both institutions. In regard to this, the Friedrich Schiller University Jena and the Fraunhofer-Gesellschaft have set up the new professorship "Technical Environmental Chemistry" within the framework of the CEEC activities in 2012.

As Fraunhofer IKTS aligns its research activities to environmental and energy topics, the existing environmental management system of the Hermsdorf branch in accordance with DIN ISO 14001 has successfully been implemented to the Dresden branch.

1 *Institute management of Fraunhofer IKTS, f.l.t.r.: Dr. Michael Zins, Dr. Ingolf Voigt, Prof. Alexander Michaelis, Prof. Michael Stelter.*

ORGANIZATIONAL CHART

FRAUNHOFER IKTS



YOUR CONTACT PERSONS



Institute Director

Prof. Dr. habil. Alexander Michaelis
Phone +49 351 2553-7512
alexander.michaelis@ikts.fraunhofer.de



Deputy Institute Director/ Head of Administration

Dr. Michael Zins
Phone +49 351 2553-7522
michael.zins@ikts.fraunhofer.de



Deputy Institute Director

Prof. Dr. Michael Stelzer
Phone +49 36601 9301-3031
michael.stelzer@ikts.fraunhofer.de



Deputy Institute Director

Dr. Ingolf Voigt
Phone +49 36601 9301-2618
ingolf.voigt@ikts.fraunhofer.de



Marketing and Strategy

Dr. Bärbel Voigtsberger
Phone +49 36601 9301-3902
baerbel.voigtsberger@ikts.fraunhofer.de



Materials

Oxide Ceramics, Hardmetals and Cermets

Dr. habil. Andreas Krell
Phone +49 351 2553-7538
andreas.krell@ikts.fraunhofer.de



Materials

Nonoxide Ceramics

Dipl.-Krist. Jörg Adler
Phone +49 351 2553-7515
joerg.adler@ikts.fraunhofer.de



Materials

Precursor-Derived Ceramics and Composites

Dr. Isabel Kinski
Phone +49 36601 9301-3931
isabel.kinski@ikts.fraunhofer.de



Processes and Components

Dr. Hagen Klemm
Phone +49 351 2553-7553
hagen.klemm@ikts.fraunhofer.de



Sintering and Characterization

Dr. habil. Mathias Herrmann
Phone +49 351 2553-7527
mathias.herrmann@ikts.fraunhofer.de



Environmental and Process Engineering High-Temperature Separation and Catalysis

Dr. Ralf Kriegel
Phone +49 36601 9301-4870
ralf.kriegel@ikts.fraunhofer.de



Environmental and Process Engineering Nanoporous Membranes

Dr. Hannes Richter
Phone +49 36601 9301-1866
hannes.richter@ikts.fraunhofer.de



Environmental and Process Engineering Chemical Engineering and Electrochemistry

Dr. Matthias Jahn
Phone +49 351 2553-7535
matthias.jahn@ikts.fraunhofer.de



Environmental and Process Engineering Biomass Technologies and Membrane Process Technology

Dr. Burkhardt Faßbauer
Phone +49 351 2553-7667
burkhardt.fassauer@ikts.fraunhofer.de



Energy Systems System Integration and Technology Transfer Marketing and Strategy

Dr. Christian Wunderlich
Phone +49 351 2553-7232
christian.wunderlich@ikts.fraunhofer.de



Energy Systems Materials and Components

Dr. Mihails Kusnezoff
Phone +49 351 2553-7707
mihails.kusnezoff@ikts.fraunhofer.de



Smart Microsystems Hybrid Microsystems

Dr. Uwe Partsch
Phone +49 351 2553-7696
uwe.partsch@ikts.fraunhofer.de



Smart Microsystems Smart Materials and Systems

Dr. Andreas Schönecker
Phone +49 351 2553-7508
andreas.schoenecker@ikts.fraunhofer.de

BOARD OF TRUSTEES

The President of the Fraunhofer-Gesellschaft has appointed the following people to the board of trustees at Fraunhofer IKTS:

Dr. G. Gille

Chairman of board of trustees
H.C. Starck GmbH & Co. KG, Goslar
Manager of Central Department Research and Development

Dr. J. Damasky

Board member of Webasto AG, Stockdorf

A. Heller

Administrative head of the Saale-Holzland region

Prof. Dr. C. Kaps

Bauhaus University Weimar, Chair of Building Chemistry

A. Krey

CEO of Landesentwicklungsgesellschaft Thüringen mbH (LEG), Erfurt

Dr. R. Lenk

CeramTec GmbH, Plochingen
Head of Central Development Department

Dr. C. Lesniak

ESK Ceramics GmbH & Co. KG, Kempten
Vice president Technology and Innovation

Dr. H.-H. Matthias

Managing director of Tridelta GmbH, Hermsdorf

Dr. R. Metzler

Managing director of Rauschert GmbH,
Judenbach-Heinersdorf

Dipl.-Ing. P. G. Nothnagel

Managing director of Wirtschaftsförderung Sachsen GmbH,
Dresden

Dipl.-Ing. M. Philipps

Endress+Hauser GmbH & Co. KG, Maulburg
Head of business sector Sensor Technology

Dr.-Ing. W. Rossner

Siemens AG, München
Head of Central Department Technology, Ceramics

Dr. K. R. Sprung

CEO of German Federation of Industrial Research Associations,
Berlin

MR C. Zimmer-Conrad

Saxon Ministry of Science and the Fine Arts
Head of Technology Policy and Technology Funding
Department, Dresden

Newly appointed:

Dipl.-Ing. R. Fetter

Thuringian Ministry of Education, Science and Culture, Erfurt

Dr. habil. M. Gude

Thuringian Ministry of Education, Science and Culture,
Head of department 5 – Energy Politics, Technology and
Research Funding, Erfurt

Dr. K.-H. Stegemann

SolarWorld Innovations GmbH, Freiberg
Division Manager Solar Cell and Module Development

THE FRAUNHOFER-GESELLSCHAFT

Research of practical utility lies at the heart of all activities pursued by the Fraunhofer-Gesellschaft. Founded in 1949, the research organization undertakes applied research that drives economic development and serves the wider benefit of society. Its services are solicited by customers and contractual partners in industry, the service sector and public administration.

At present, the Fraunhofer-Gesellschaft maintains 66 institutes and independent research units. The majority of the more than 22,000 staff are qualified scientists and engineers, who work with an annual research budget of 1.9 billion euros. Of this sum, more than 1.6 billion euros is generated through contract research. More than 70 percent of the Fraunhofer-Gesellschaft's contract research revenue is derived from contracts with industry and from publicly financed research projects. Almost 30 percent is contributed by the German federal and Länder governments in the form of base funding, enabling the institutes to work ahead on solutions to problems that will not become acutely relevant to industry and society until five or ten years from now.

Affiliated international research centers and representative offices provide contact with the regions of greatest importance to present and future scientific progress and economic development.

With its clearly defined mission of application-oriented research and its focus on key technologies of relevance to the future, the Fraunhofer-Gesellschaft plays a prominent role in the German and European innovation process. Applied research has a knockon effect that extends beyond the direct benefits perceived by the customer: Through their research and development work, the Fraunhofer Institutes help to reinforce the competitive strength of the economy in their local region, and throughout Germany and Europe. They do so by promoting innovation, strengthening the technological base, improving the acceptance of new technologies, and helping to train the urgently needed future generation of scientists and engineers.

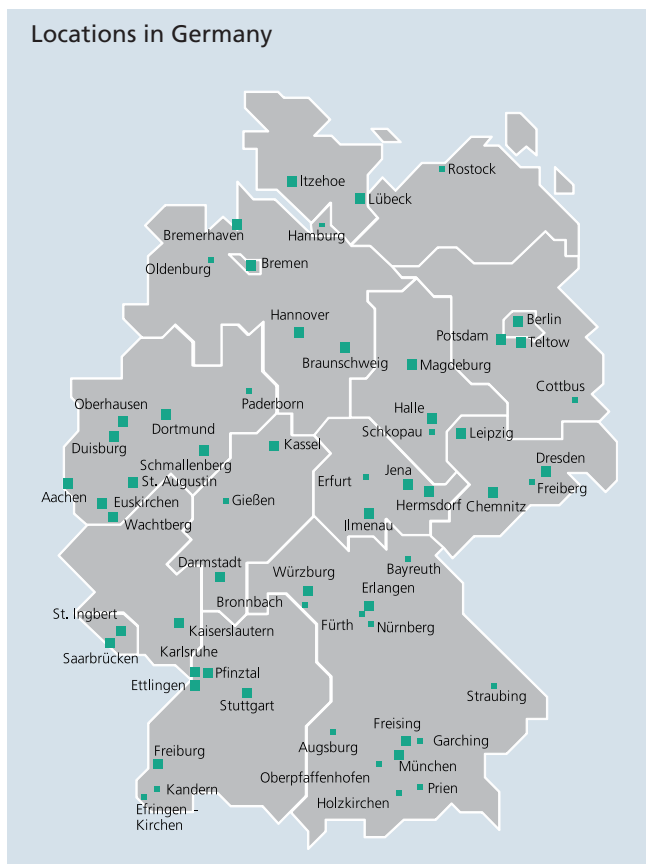

As an employer, the Fraunhofer-Gesellschaft offers its staff the opportunity to develop the professional and personal skills that will allow them to take up positions of responsibility within their institute, at universities, in industry and in society. Students who choose to work on projects at the Fraunhofer Institutes have excellent prospects of starting and developing a career in industry by virtue of the practical training and experience they have acquired.

The Fraunhofer-Gesellschaft is a recognized non-profit organization that takes its name from Joseph von Fraunhofer (1787–1826), the illustrious Munich researcher, inventor and entrepreneur.

EVENTS AND AWARDS





February 22, 2012

FuelCell Energy Solutions GmbH founded

The US FuelCell Energy, Inc. (FCE), a leading manufacturer of ultra-clean, efficient and reliable power plants, announced a joint venture with Fraunhofer IKTS in February 2012. It is the aim to develop the European market for ultra-clean stationary Direct FuelCell (DFC®) power plants ranging in output from 250 kW to 2.8 MW. Since June 2012, Fraunhofer IKTS has been holding 25 % of the shares in the joint venture FuelCell Energy Solutions GmbH (FCES) with its registered office in Dresden.

FCES uses the MCFC technology (molten carbonate fuel cell) for its fuel cells. Using this technology, extremely large fuel cell stacks can be realized. So, the technology cuts out for the efficient baseload power in the MW class. DFC power plants are powered with natural gas or renewable biogas, and can achieve up to 90 % efficiency when configured to use the high-quality heat generated by the power plant in a combined heat and power (CHP) mode.

March 2, 2012

Anniversary ball "20 years of Fraunhofer in Dresden"

In the past 20 years, Dresden has become the largest Fraunhofer site in Germany and with 1300 employees an important employer in the region. The six Fraunhofer Institutes and seven institutions have a strong network with local industry partners and generate projects with a volume of more than 130 million euros per year. By building the Fraunhofer Research Center for Resource-Friendly Energy Technologies, by establishing a nano-electronics center, by enlarging the Fraunhofer Institute Center Dresden as well as by building a new pilot plant with adjoining test facility, the success story can be continued. On March 2, 2012, the anniversary ball took place at Dresden airport. Together with customers, partners, public funding bodies, trustees and those who have accompanied Fraunhofer on this way, the

Fraunhofer staff celebrated the 20th anniversary. Stanislaw Tillich, Minister President of the Free State of Saxony, Prof. Hans-Jörg Bullinger, the then President of the Fraunhofer-Gesellschaft, Dirk Hilbert, first mayor of Dresden, Dr. Alexander Imbusch, chairman of the Fraunhofer Foundation and Prof. Hans Müller-Steinhagen, President of Technische Universität Dresden were among the guest speakers. Enjoying the extraordinary atmosphere at Dresden airport, the 2000 guests strolled, danced and visited the numerous cultural highlights. So, the ball became an unforgettable event.

1 Guest speaker Stanislaw Tillich, Saxon Minister President, at the anniversary ball "20 years of Fraunhofer in Dresden" at Dresden Airport.

2, 3 Announcement of a joint venture of the world leading fuel cell manufacturer FuelCell Energy, Inc. (FCE) from Danbury/Connecticut (USA) with Fraunhofer IKTS by Chip Bottone, president of FCE, Inc. (l.) and Prof. Alexander Michaelis, institute director of Fraunhofer IKTS.



May 20–24, 2012

10th CMCEE – International Symposium on Ceramic Materials and Components for Energy and Environmental Applications and CERAMITEC 2012

From May 20 to 24, 2012, the CMCEE conference took place in Germany for the first time. Under the topic “Ceramic Components and Materials for Energy and Environmental Technology”, 600 experts met in the International Congress Center Dresden. Speakers from 50 countries presented latest research results, discussed and identified current and future trends in the field of advanced ceramics. The comprehensive program jointly organized by Fraunhofer IKTS and the German Ceramic Society comprised 330 presentations as well as 80 scientific posters.

On May 24, the conference was continued as “Day of Technical Ceramics” at the CERAMITEC fair in Munich. Numerous conference participants visited the fair as speaker or discussion partner.

The successful conference series will be continued in Vancouver in 2015 under the chairmanship of Dr. Mrityunjay Singh, Ohio Aerospace Institute.

May 31, 2012 and December 5, 2012

Cornerstone and topping-out ceremony for extension building in Hermsdorf

On May 31, 2012, the cornerstone ceremony for the extension building in Hermsdorf took place in the presence of Christine Lieberknecht, the Minister President of the Free State of Thuringia, Prof. Alexander Michaelis, the institute director of Fraunhofer IKTS and Prof. Alfred Gossner, executive board member of the Fraunhofer-Gesellschaft.

12 million euros are invested in the three-story building comprising laboratories, offices and pilot plants on nearly 2775 square meters of usable floor space, and another 6 million euros in new scientific equipment and devices.

In future, the scientists work on three strategic research topics related to the GreenTech strategy of the Free State of Thuringia.

On December 5, 2012, the topping-out ceremony took place where representatives from politics and business offered their congratulations.

After the planned completion at the end of 2013, an increase of personnel is planned. The number of staff is to be increased from 130 to 150 at the Hermsdorf branch by 2015.

July 6, 2012

10th Long Night of Sciences broke all records

The Dresden Long Night of Sciences celebrated its 10th anniversary and its organizers provided an outstanding event. On July 6, 2012, four universities as well as 38 research institutions and scientific-oriented companies opened their doors, laboratories, auditoriums and archives. More than 120 events were offered for children and pupils, in particular. As the year before, 35,000 visitors came to join the interesting program despite heavy thunderstorms.

Under the motto “20 years of Fraunhofer in Dresden”, the scientists of the Fraunhofer Institute Center presented highlights from their diversified portfolio. 2900 visitors could join exciting experiments, guessing games, presentations and an outstanding children’s program.

August 16, 2012

Center for Energy and Environmental Chemistry (CEEC) announced

In August 2012, the establishment of the Center for Energy and Environmental Chemistry (CEEC) in Jena was announced within the framework of a press conference.

Under the umbrella of the CEEC, scientists from the Friedrich Schiller University (FSU) and the Fraunhofer Institute for



Ceramic Technology and Systems IKTS will work together and develop ceramic and polymer materials for energy storage, generation and environmental technologies. Additionally, prototypes are built, guaranteeing a close connection between basic and applied research.

The existing working groups of FSU and Fraunhofer IKTS are supplemented by two new established research groups as well as a junior professorship for electrochemistry which is financially supported by the Carl Zeiss Foundation.

At present, the scientists still work at different sites. In a second step, a new building for electrochemistry with 1200 square meters of usable floor space will be erected in Jena until summer 2015.

August 22, 2012

Battery pilot plant opened in Pleiße

ThyssenKrupp System Engineering GmbH and Fraunhofer IKTS together with KMS Technology Center GmbH and AWEBA Werkzeugbau GmbH jointly work on new technologies for the efficient and cost-effective production of battery cells.

The solutions worked out in the joint "LiFab" project are validated and tested in the new 1800 m² pilot plant, which was opened in the presence of the Saxon Minister President Stanislaw Tillich on August 22, 2012.

Fraunhofer IKTS is involved in the manufacturing of battery electrodes which are responsible for the performance and reliability of battery cells. Based on the gained knowledge, more efficient processes can be defined, and in future, the productivity and cost structures of production plants for Li-ion batteries can significantly be improved.

October 19, 2012

Bioenergy Application Center opened

The Fraunhofer Institute for Ceramic Technologies and Systems IKTS and Lehmann Maschinenbau GmbH pool their skills in the field of biomass utilization. Therefore, they opened the Bioenergy Application Center in Pöhl/Saxony in October 2012. The application center serves to determine processes, to perform long-term tests and to upscale processes for making biogas production and use effective. What makes this so special is that the methods are always developed in connection with the appropriate equipment. In this way, the aimed market maturity and broad application can be achieved faster.

Aside from using and further optimizing the existing equip-

1 Participants of the 10th CMCEE in Dresden.

2 Prof. Sabine von Schorlemer (2nd from right), Saxon State Minister for Science and Arts, before her welcome speech at the 10th CMCEE.

3 Christine Lieberknecht, Thuringian Minister President (left), laying the foundation stone for the extension building of the Fraunhofer IKTS in Hermsdorf.

4 Opening of the battery pilot plant in Pleiße in the presence of the Saxon Minister President Stanislaw Tillich (center).

5 Congratulations of Frank Kupfer, Saxon State Minister of the Environment and Agriculture (right), on occasion of the opening of the Bioenergy Application Center in Pöhl.

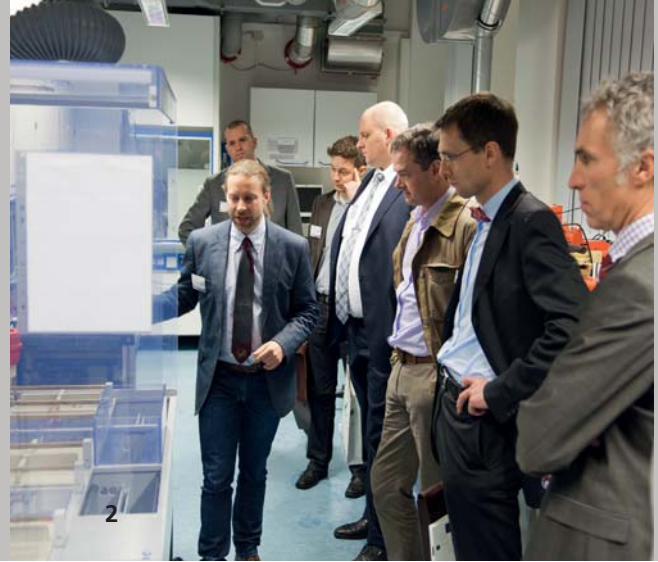

ment, the application center is used to develop and study new ideas. Furthermore, it is used to regularly host conferences and training courses. Thus, best prospects are offered for young scientists and technicians, resulting in a new generation of scientists and new jobs in the region.

November 9–11, 2012

Fourth Fraunhofer Talent School

In November 2012, three Dresden Fraunhofer Institutes invited students of the tenth to thirteenth grade to a researcher's course. For one weekend, 35 young persons interested in science had the opportunity to discuss about current research topics as well as to experiment and develop own ideas in one of three workshops. At Fraunhofer IKTS, the students worked on the promising fuel cell technology. Aside from exchanging knowledge and deepening the understanding, the students focused on project-oriented working.

The Dresden Fraunhofer Institutes plan to host the fifth Fraunhofer Talent School in November 2013.
www.talent-school-dresden.de

November 29–30, 2012

Symposium: Anodization – From corrosive protection to nanotechnology

More than 60 participants from Germany, Austria and Switzerland participated in the symposium series "Applied electrochemistry in materials science" which has already taken place for the third time at Fraunhofer IKTS. In addition to traditional topics of anodization such as corrosive or wear protection, the 19 speakers from science and industry also presented new applications in the field of nanotechnology, where anodized layers are used as templates. So, the gap between basic research and application-oriented works on electrolytic oxidation was bridged. Presentations on measurement techniques related to

the formation and investigation of oxide layers or the manufacturing process supplemented the program. The symposium was completed by a small exhibition of seven companies. On account of the very positive response of the participants the symposium is planned to be continued in November 2014.

December 5, 2012

GreenTech Campus Hermsdorf started

Within the framework of a press conference, the GreenTech Campus Hermsdorf was started – a site for industry-oriented research institutions and companies in the field of energy and environmental engineering. The campus is financially supported and established by the Free State of Thuringia and Fraunhofer IKTS. Matthias Machnig, Thuringian Minister of Economic Affairs, and Prof. Dr. Alexander Michaelis, director of Fraunhofer IKTS, presented the plans for the new campus of innovations which will be established around Fraunhofer IKTS in Hermsdorf.

In this connection, a new battery pilot plant will be erected until mid 2014, in which new energy storage systems will be developed, existing battery types tested and further developed. Furthermore, Matthias Machnig held out the prospect of supporting the erection of a fuel cell pilot plant. It is the aim of the GreenTech Campus activities to transfer research results faster into industrial applications. Local companies as well as Hermsdorf, as a powerful industrial region where further companies will settle, will benefit from these activities. So, FuelCell Energy Solutions GmbH (FCES), a joint venture of FuelCell Energy, Inc. (FCE), a leading manufacturer of fuel cells, and Fraunhofer IKTS, has already announced to settle.



Awards

Prof. Alexander Michaelis receives the Bridge Building Award by the American Ceramic Society

Prof. Alexander Michaelis, director of the Fraunhofer Institute for Ceramic Technologies and Systems IKTS, was awarded the ACerS Bridge Building Award at the 36th International Conference and Exposition on Advanced Ceramics and Composites (ICACC) in Daytona Beach on January 23, 2012. With more than 1100 participants from more than 50 countries, this conference is one of the most important international events in the field of advanced ceramics. The Bridge Building Award, which is annually awarded by the American Ceramic Society, recognizes individuals who have made outstanding contributions to engineering ceramics and thus significantly contributed to the visibility of the field and international advocacy. The award, in particular, recognizes Michaelis' contribution in the field of energy and environmental technology.

Biogas Innovation Award 2012

The Biogas Innovation Award of the German Farmers' Association was given to Fraunhofer IKTS. So, the institute shared the award of the category "Research" with the Institute of Agricultural and Urban Ecology Projects at Humboldt-Universität Berlin. Anne Deutschmann of Fraunhofer IKTS was honored for her contributions in the field of "Practice-oriented evaluation and optimization of mixing processes". The award, which is donated by the Landwirtschaftliche Rentenbank, has already been awarded for the third time within the framework of the Biogas Innovation Congress taking place in Osnabrück on May 10 and 11, 2012. The congress is dedicated to important new and further developments in the field of biogas, which is an essential element of the "energy transition".

Dresden Congress Award

The "Oscar" of the Dresden Convention Industry has already been awarded for the ninth time by the City of Dresden and the Dresden Convention Bureau. Within the framework of an award ceremony in the Taschenbergpalais Kempinski on November 6, 2012, Dresden mayor Helma Orosz presented the awards in four categories. In the category "501 to 1000 participants" the prize was given to Prof. Alexander Michaelis, institute director at Fraunhofer IKTS, for the organization of the 10th CMCEE – International Symposium on Ceramic Materials and Components for Energy and Environmental Applications. 600 participants from more than 50 countries took part in the conference in May 2012.

Since 2004, the Dresden Congress Award has been honoring scientists, companies and congress organizers, who have brought outstanding conferences to Dresden, and thus have strengthened the economy of the Saxon capital.

- 1 35 students from across Germany successfully participated in the fourth Fraunhofer Talent School in Dresden.
- 2 Participants of the symposium "Anodization – From corrosive protection to nanotechnology" visiting Fraunhofer IKTS.
- 3 Matthias Machnig, Thuringian Minister of Economic Affairs (2nd from right) starting the GreenTech Campus in Hermsdorf within the framework of a press conference.
- 4 Winner of the Biogas Innovation Award in the category "Research".



Cooperative agreements

Cooperative agreement with Mayur REnergy Solutions Inc.

Mayur REnergy Solutions Inc. with its headquarters in India and the USA signed a cooperative agreement with Fraunhofer IKTS in January 2013 in order to be able to provide clean and environmental-friendly energy alternatives at fair prices. Both parties agreed to jointly develop fuel cell systems (SOFC) and to establish a decentralized power grid, in order to find a sustainable solution for energy supply problems in India and other developing countries.

Within the framework of the promising project, Fraunhofer IKTS will develop first prototypes until 2014, which are based on the introduced eneramic® fuel cell system. This system is to be adjusted to higher power classes.

Memorandum of understanding signed with the Korean company POSCO

On January 2013, the Fraunhofer-Gesellschaft and the Korean company POSCO signed a memorandum of understanding at Fraunhofer IKTS. POSCO (Pohang Iron and Steel Company) is the fourth largest steel manufacturer in the world. Additionally, the company has numerous subsidiaries working in the fields of energy as well as material and chemistry. The signing of the MoU was accompanied by a workshop where the Fraunhofer Energy Alliance presented its research topics. It was the aim of the workshop to explore all opportunities of a profitable cooperation for both parties. The Korean delegation was led by Dr. Kwon, Chief Technical Officer (CTO) of POSCO. Representatives of Fraunhofer IKTS and three other Fraunhofer Institutes took part in this workshop. The signed MoU is to facilitate the initiation of joint projects in the future.

1 Dresden Congress Award 2012 for the successful organization of the 10th CMCEE by Fraunhofer IKTS.

2 Dr. Kwon, Chief Technical Officer (CTO) of POSCO, after signing the memorandum of understanding with Fraunhofer-Gesellschaft.

PARTICIPATION IN TRADE FAIRS 2012



JANUARY

Biogas Trade Fair
Bremen, January 10–12, 2012

FEBRUARY

nano tech
Tokyo, February 15–17, 2012
Joint Fraunhofer booth

Fuel Cell Expo
Tokyo, February 29–March 2, 2012
Joint booth with eZelleron GmbH

MARCH

Jena Industry Days
Jena, March 28–29, 2012

APRIL

Hannover Messe
Hannover, April 23–27, 2012
Joint booth of Fraunhofer Energy Alliance
Joint booth of Fuel Cell Initiative Saxony
Joint booth of Mikro-Nanotechnologie Thüringen e.V.
Joint booth of LEG Thüringen

1 Presentation of the transparent exhaust system at CERAMITEC 2012.



MAY

IFAT

München, May 7–11, 2012

Joint booth of Fraunhofer SysWater Alliance

SMT/HYBRID/PACKAGING

Nürnberg, May 8–10, 2012

Joint booth "Future Packaging 2012"

Open Day in Dresden Rossendorf

Dresden-Rossendorf, May 12, 2012

Joint booth with Materials Research Network Dresden e.V. (MFD)

Sensor + Test

Nürnberg, May 22–24, 2012

Joint booth "Future Packaging 2012"

CERAMITEC

München, May 22–25, 2012

JUNE

Opening of sewage treatment plant Dresden-Kaditz

Dresden, June 8, 2012

Open Day – Stadtentwässerung Dresden

(Sewage treatment plant)

Dresden, June 10, 2012

NanoFair

Dresden, June 12–13, 2012

Joint booth with Materials Research Network Dresden e.V. (MFD)

Actuator

Bremen, June 18–20, 2012

Joint booth of Fraunhofer Adaptronics Alliance

Achema

Frankfurt, June 18–22, 2012

European Fuel Cell Forum

Lucerne, June 26–29, 2012

JULY

ICIM (International Conference on Inorganic Membranes)

Twente, July 10–13, 2012

SEPTEMBER

EuroPM

Basel, September 16–19, 2012

EU PVSEC

Frankfurt, September 24–28, 2012

Joint booth of Saxony Economic Development Corporation

OCTOBER

Battery+Storage

Stuttgart, October 8–10, 2012

Joint booth of Fraunhofer Battery Alliance

Materialica

München, October 23–25, 2012



NOVEMBER

Innovation Day Thuringia

Erfurt, November 2, 2012

Cellular Materials

Dresden, November 7–9, 2012

Electronica

München, November 13–16, 2012

Joint booth with ANCCeram GmbH

Hybridica

München, November 13–16, 2012

Joint booth of Expert Group on Ceramic Injection Molding

Euromold

Frankfurt, November 27–30, 2012

Joint booth of Fraunhofer Additive Manufacturing Alliance

Hagen Symposium

Hagen, November 29–30, 2012

1 Interested visitors informing about the “Cordless Energy Transfer” exhibit at the joint booth of the Fraunhofer Energy Alliance during Hannover Messe 2012.

2 “From Fuels to Electricity” exhibit at the joint booth of the Fuel Cell Initiative Saxony during Hannover Messe 2012.

3 Successful trade fair participation within the framework of the “Day of Technical Ceramics” at CERAMITEC 2012.

4 Presentation of innovative membrane concepts during Achema in Frankfurt.

5 Presentation of the Fraunhofer IKTS fuel cell competencies at the accompanying exhibition of the European Fuel Cell Forum in Lucerne.

RESEARCH FIELD

MATERIALS

Department heads:

Dr. habil. Andreas Krell

Dipl.-Krist. Jörg Adler

Dr. Isabel Kinski

Profile

The core competency of the "Materials" research field lies in the development of new or modified ceramic materials and composites (e.g. ceramic-metal, ceramic-fiber, ceramic-ceramic) with the use and generation of state-of-the-art technologies.

Our offering ranges from targeted synthesis of raw materials from ceramic precursors, so called precursor ceramics, or renewable raw materials and application-oriented materials development to technological trials and manufacture of prototype parts and systems, including characterization and testing. Material-specific and technological aspects for industrial applications and safety-/health-related aspects are considered.

One focus of materials qualification is the development of low-defect and low-cost processes. Our wide range of capabilities encompasses powder processing technologies for simply structured ceramic materials as well as fiber processing and coating technologies for composite materials and functional coatings such as transparent conducting oxides.

The successful development of new application fields through targeted combination of structural and functional properties in ceramics and ceramic-metal composites is reflected, for example, in the development of high-temperature materials, electrically conducting ceramics, thermoelectric materials, cutting, grinding and forming tools, protection and biomaterials, transparent components and optical ceramics, functional ceramic coatings, and filters.

Services offered

- Particle synthesis, surface modification and doping
- Integrated materials and process development for novel high-performance ceramics and hardmetals
- Development and supply of raw materials, trial parts, and complex components
- Expert opinions on production and application problems
- Materials testing (mechanical, tribological, electrical, and corrosive properties at room and high temperatures)
- Damage and failure analysis of components and tools
- Evaluation of safety and health risks from use of fine powders and materials
- Characterization of wetting behavior of coatings and surface tension of liquids
- Characterization of corrosion behavior under realistic application conditions (hot gas corrosion)

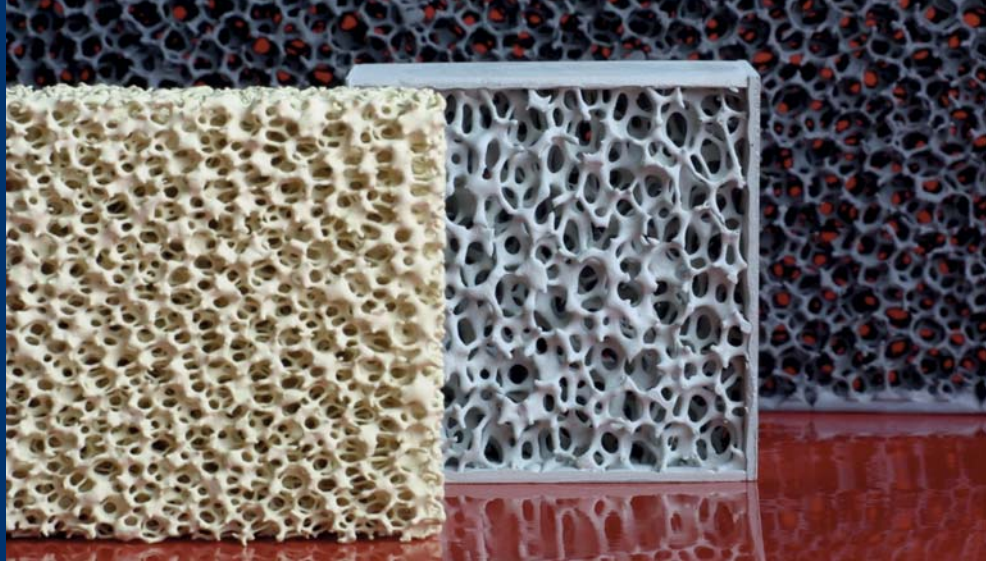

Department head
Oxide Ceramics, Hardmetals and Cermets

Oxide Ceramics
Dr. habil. Andreas Krell
Phone +49 351 2553-7538
andreas.krell@ikts.fraunhofer.de



Department head
Precursor-Derived Ceramics and Composites

Precursor-Derived Ceramics
Dr. Isabel Kinski
Phone +49 36601 9301-3931
isabel.kinski@ikts.fraunhofer.de



Hardmetals and Cermets
Dr. Volkmar Richter
Phone +49 351 2553-7614
volkmar.richter@ikts.fraunhofer.de



Pilot Manufacturing of High-Purity Ceramics
Dipl.-Ing. (FH) Frank Kastner
Phone +49 36601 9301-4300
frank.kastner@ikts.fraunhofer.de



Department head
Nonoxide Ceramics

Carbide Ceramics and Filter Ceramics
Dipl.-Krist. Jörg Adler
Phone +49 351 2553-7515
joerg.adler@ikts.fraunhofer.de



Oxide and Polymer-Ceramic Composites
Dipl.-Ing. Henry Ludwig
Phone +49 36601 9301-4968
henry.ludwig@ikts.fraunhofer.de



Nitride Ceramics and Structural Ceramics with Electrical Function
Dr. Hans-Peter Martin
Phone +49 351 2553-7744
hans-peter.martin@ikts.fraunhofer.de

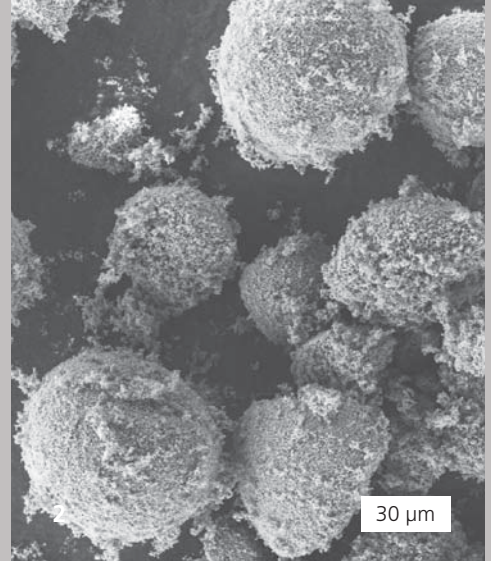

MgO – TRANSPARENT CERAMICS WITH HIGH THERMAL CONDUCTIVITY

Dipl.-Ing. Thomas Hutzler, Dr. Andreas Krell

Due to its high thermal stability magnesium oxide (MgO) is well known as a classic refractory material. Having a melting temperature of more than 2800°C, MgO belongs to the group of high-temperature ceramics. Being an outstanding electric insulator with good thermal conductivity it is widely used in porous or gas-tight components, sheath thermocouples and heating elements as well as cartridge heaters. If those both properties are combined with the birefringence-free optic transparency, which is attributed to the cubic structure in a broad wavelength range, transparent MgO ceramics become a promising candidate for a number of new applications, e.g. in lighting industry, optical systems and laser technology as well as for thermal sensor and control technologies.

Within the frame of preliminary research activities a technological screening of commercial MgO powders provided, on the one hand, a reliable base of appropriate raw materials. On the other hand, a successful manufacturing technology on laboratory scale was developed using the extensive experiences on defect-free manufacturing methods at Fraunhofer IKTS. In order to obtain a high optical transmission – aside from the physical conditions for transparency – the following requirements on the properties of raw materials and sintered ceramics must be met:

- Raw materials free of contaminations and impurity phases and with a purity of about 99.99 % of the MgO powder.
- Highly dispersed starting powders that are sufficiently fine-grained and exhibit a high sintering activity.
- No visible defects throughout the completely dense sintered material.

Manufacturing technology

As result of the raw material screening, two commercially available MgO powders of Japanese manufacturers proved to be suitable. With specific surfaces (BET) of 8-10 m²/g and mean particle sizes of about 180 nm, these two powders match the requirements on purity as well as on particle size.

In order to easily transfer the method to industrial scale, the technological approach is limited to the following three process steps common to the industry:

1. Preparation of a ready-to-press MgO granulate:
After careful deagglomeration of powder particles in alcohol and homogenization with suitable organic additives (dispersants and pressing agents) by attrition milling, the slurry was dried in a rotary evaporator and granulated.
2. Shaping:
By combination of uniaxial with subsequent cold-isostatic pressing (CIP) on laboratory and pilot scale, smaller disk-shaped specimens with a diameter of 30 mm as well as larger square plates with a side length of 80 mm and a thickness of 10 mm were obtained for first tests.
3. Heat treatment:
After debinding at 800°C the MgO ceramics are completely densified by pre-sintering in air and hot-isostatic pressing (HIP) in argon at optimized temperatures.

Foreign particles with a refractive index significantly deviating from MgO as well as residual porosity might result in optical scattering and thus in a loss of transparency. Therefore, contaminations of the high-purity starting materials have to be

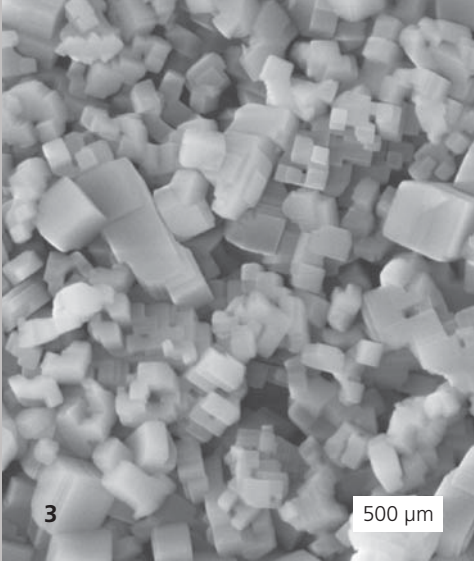

avoided during the entire manufacturing process. For that reason, slurry preparation was performed with wear-resistant high-purity (> 99.9 %) Al_2O_3 grinding balls manufactured by Fraunhofer IKTS with a sub- μm grain size at > 99.9 % relative density. Different from the production of windows from molten glass, the manufacture of transparent sintered ceramics with measurable (and usable) optical properties needs a final surface finish by grinding and polishing after heat treatment.

Material properties

With a refractive index of 1.736 (at 600 nm wavelength) the theoretical maximum transmission of MgO is 86.5 %. Using the technology described above transparent MgO ceramics are obtained with a real in-line transmission of 80 %, measured at polished samples with a thickness of 4 mm at $\lambda = 640 \text{ nm}$. The transmission spectrum shows a consistently high transmittance between 78 and 82 % over the entire wavelength range of visible light $\lambda \approx 380\text{-}780 \text{ nm}$. In the range of ultraviolet light $\lambda = 200\text{-}350 \text{ nm}$, MgO ceramics still allow a transmission of 23-77 %.

The thermal conductivity measured at the same material is 47 W/mK ($T_{\text{measurement}} = 53.6^\circ\text{C}$) which is significantly higher than the values of comparable other transparent ceramics such as cubic spinel (MgAl_2O_4) with approx. 15 W/mK or birefringent Al_2O_3 with 20-30 W/mK.

Services offered

- Development and manufacturing of transparent test specimens and demonstrators with adjusted optical, thermal and mechanical properties
- Advanced further property optimization

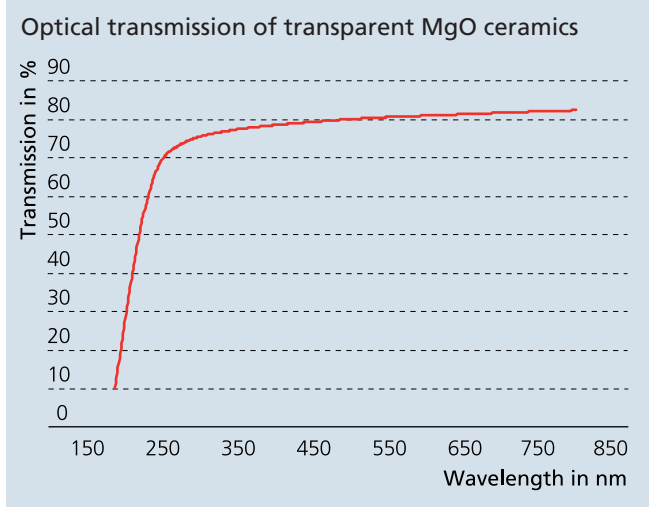

- 1 Transparent MgO disks with a diameter of 25 mm.
- 2 Highly agglomerated, high-purity MgO raw material powder.
- 3 Cubic MgO primary particles.
- 4 Transparent MgO plate with a side length of 60 mm.

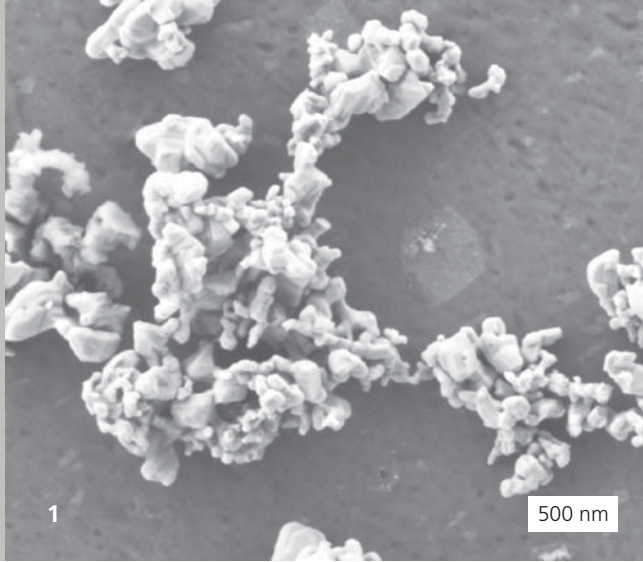

SINTERING OF TUNGSTEN CARBIDE CERAMICS

Dipl.-Ing. Johannes Pötschke, Dr. Volkmarr Richter

Traditional cemented carbides or cermets consist of a hard and strong tungsten carbide (WC) skeleton and a soft and tough metal binder phase like Co, Ni or Fe. In order to obtain high hardness and strength the binder content can be lowered and/or a finer starting powder can be used. However, the highest hardness is achieved without any metal binder. This pure WC ceramic material is commonly known as binder free or binderless hardmetal, cemented carbide or tungsten carbide.

Results and properties

The production process developed in the "Hardmetals and Cermets" working group at Fraunhofer IKTS enables the sintering of tungsten carbide ceramics in standard high-temperature furnaces at a temperature below 2000°C. By optimizing the starting material and additives as well as by controlling the processing, totally dense parts with extraordinary properties can be produced in large quantities. These special properties include a very high hardness with values up to 2900 HV10, a (especially for ceramics) quite high fracture toughness above 7 MPa·m^{1/2} and a very fine microstructure with a mean chord length below 200 nm. In contrast to cemented carbides the hardness as well as the fracture toughness increase with declining chord lengths. Due to the absence of any metal binder, tungsten carbide ceramics are characterized by a high corrosion and abrasion resistance.

By carefully adjusting the composition, milling condition and the sintering regime, a wide range of tungsten carbide ceramic

Property	Unit	Value
Melting temperature	°C	2800
Hardness	HV10	2400–2900
	HV0.1	Up to > 3400
Fracture toughness	MPa·m ^{1/2}	6–7.5
Young's modulus	KN/mm ²	720
Coefficient of thermal expansion	10 ⁻⁶ /K	3.7 (RT)–5.0 (800°C)
Thermal conductivity	W/m·K	130 (RT)–60 (1000°C)

materials can be produced. Materials with a grain size and a grain size distribution between 0.1 and 100 µm can be achieved.

Within the framework of the developed technology the sintering temperature in gas pressure sintering can be reduced up to temperatures that are commonly used in the traditional production processes of hardmetals. Current research works on an even further reduction.

Applications

Tungsten carbide ceramics are well suited for applications in which high hardness, wear resistance, resistance against acids as well as a high surface quality are required. Therefore, tungsten carbide ceramics are used for the production of highly precise and hard glass pressing dies, extreme wear-resistant water jet nozzles, mechanical seals and in special cases as cutting material for wood and similar materials.

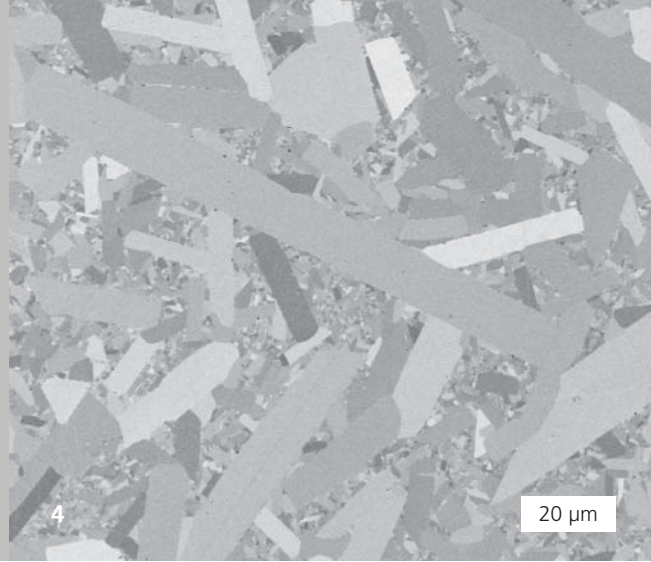
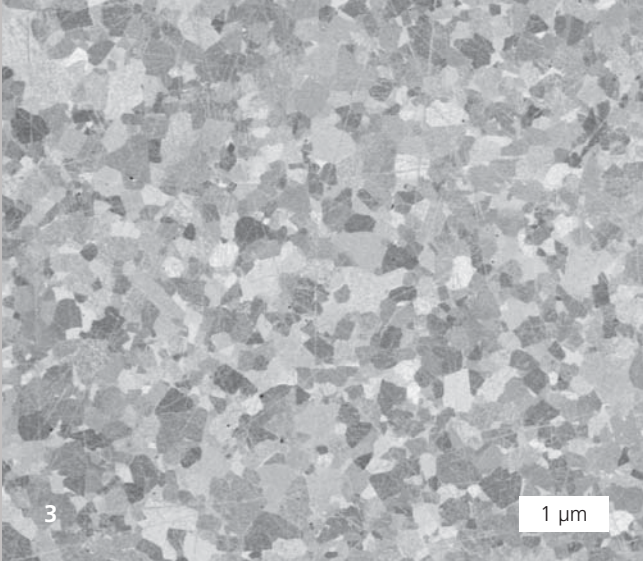

Influence of powder treatment on the densification behavior of tungsten carbide ceramics

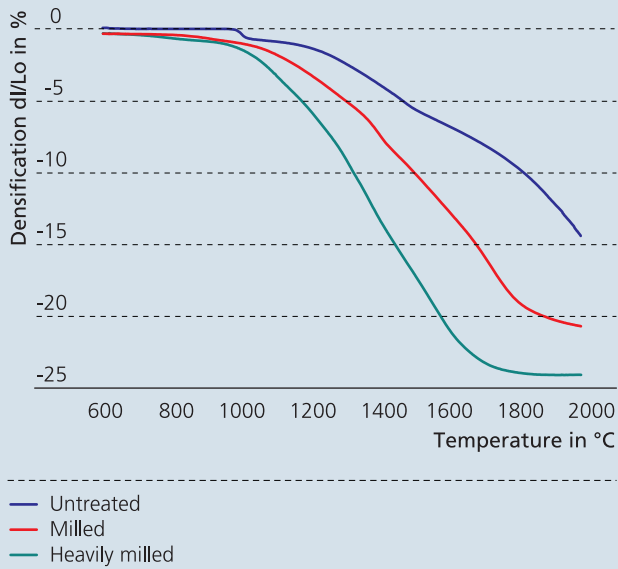

Services offered

- Optimization and production of binderless tungsten carbide ceramics for special applications and production environments
- Development of cemented carbides or tungsten carbide free cermets
- Characterization of hardmetals or cermets
- Failure analysis

Hardness and fracture toughness of a nano-scaled binder-containing and binderless tungsten carbide hardmetal

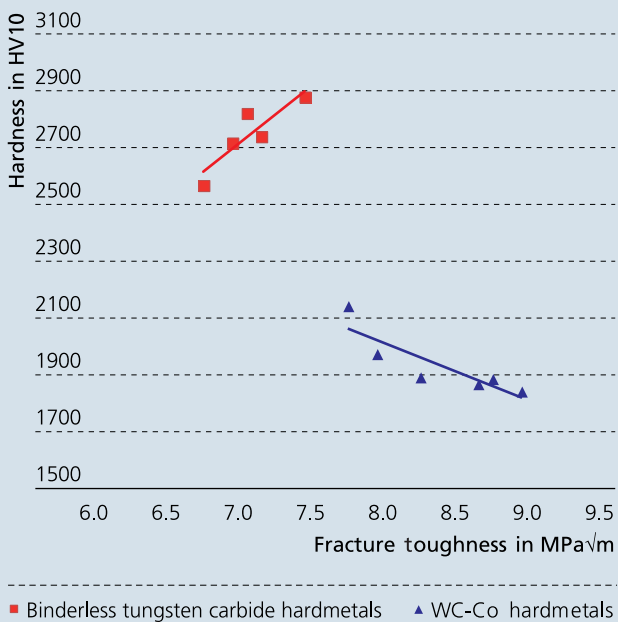

- 1 Nano-scaled tungsten carbide starting powder.
- 2 Die made from nano-scaled tungsten carbide ceramics for the pressing of glass lenses.
- 3 Nano-scaled microstructure of tungsten carbide ceramics.
- 4 Bimodal microstructure of tungsten carbide ceramics.

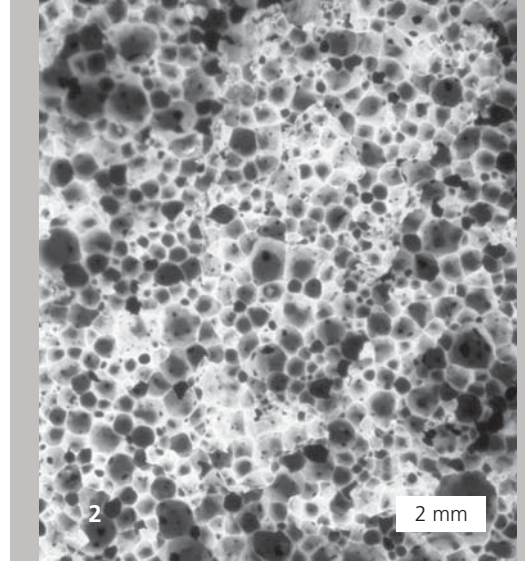

A CERAMIC FOAMING TECHNOLOGY FOR HIGH-TEMPERATURE INSULATION MATERIALS

Dipl.-Ing. Fabian Luthardt, Dipl.-Krist. Jörg Adler

Ceramic foams are used in a broad range of applications as they combine their ceramic properties such as high-temperature resistance with the kind of pore morphology. The last-mentioned is mainly determined by the manufacturing method. Open-cell foams used as burners and filters are manufactured using the replication of a sacrificial foam template. Closed-cell foams can be used for high-temperature insulation materials.

A convenient method for producing high-temperature insulating ceramic foams in an industry-relevant way is the continuous foaming of ceramic slurries. Here, the slurry and the gas phase are directly mixed to the final foam without using any foam templates or fugitive pore formers. A unique foaming device was developed at Fraunhofer IKTS to produce the foams in a continuous process.

Inside the foam generator a static mixing element mixes slurry and air. The slurry is fed by a pump and the air is passed through a porous membrane. In a second mixing area, a hardener component is mixed to the foam which allows a faster consolidation of the wet foam. The resulting wet foam is filled into simple, non-absorbing molds. Afterwards, the foam is dried, removed from the molds and heat treated. The porosity and pore size of the foam are determined by the slurry flow, the gas flow and the foaming behavior of the slurry. Porosities up to 90% with pore sizes between 200 μm and 2 mm can be obtained.

This direct foaming technology does not require any harmful fibers. The porosity of the foams only results from the homogeneous distribution of the air bubbles in the wet foam. In contrast to foams that are produced with blowing agents, the continuous foams can be produced isotropically. It is another benefit of this technology that significantly less emission is

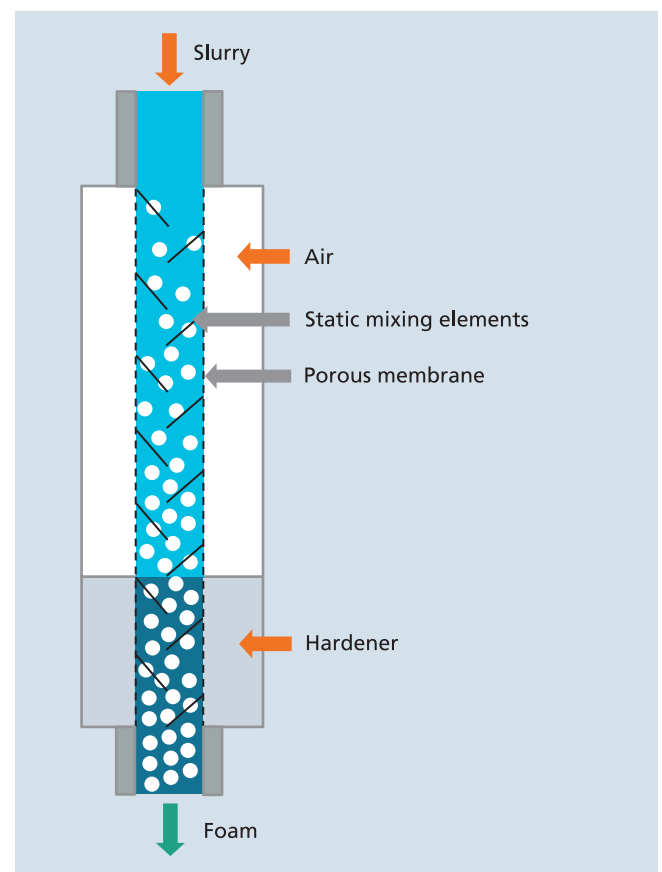

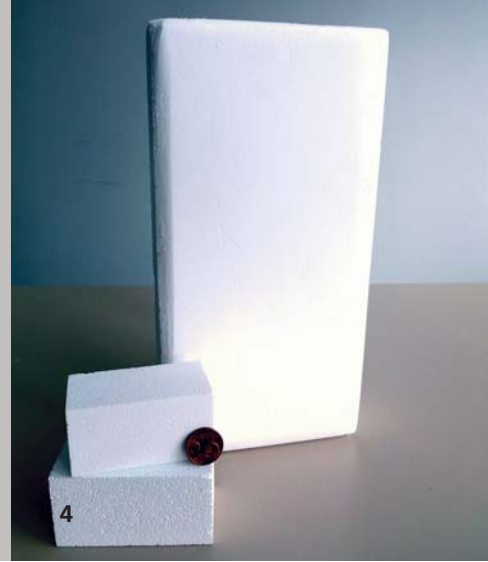

produced as compared to foams where organic, pore foaming particles are used. Using high-purity aluminum oxide the foam is perfectly suited as high-temperature insulation material up to 1700°C.

It is the aim of the project to develop alumina foams with low thermal conductivity and a sufficient mechanical strength. With regard to porosity, both required properties are opposed to each other. The continuous foaming technology and the controlled consolidation of the foam allow a homogeneous and reproducible foam morphology that is the key factor for combining thermal and mechanical requirements. The continuous foaming technology allows the manufacturing of industry-relevant geometries and quantities to be used as lightweight refractory brick.

Services offered

- Development of cellular ceramics
- Development and transfer of manufacturing technologies for components made of cellular ceramics
- Prototyping and prototype testing

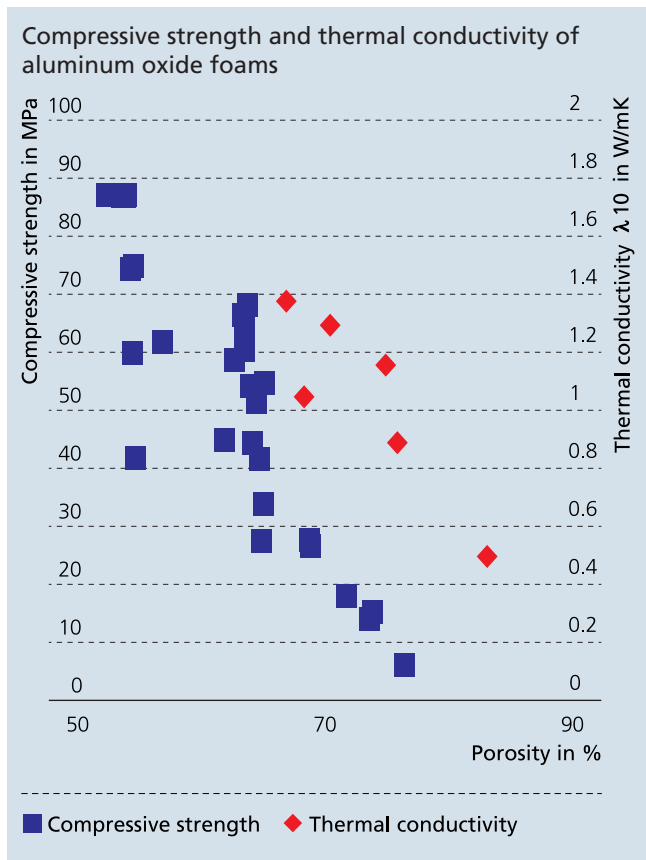

- 1 Foaming device.
- 2 Foam morphology.
- 3 Foams made of aluminum oxide, silicon carbide and brick-dust.
- 4 Lightweight refractory brick made of aluminum oxide foam.

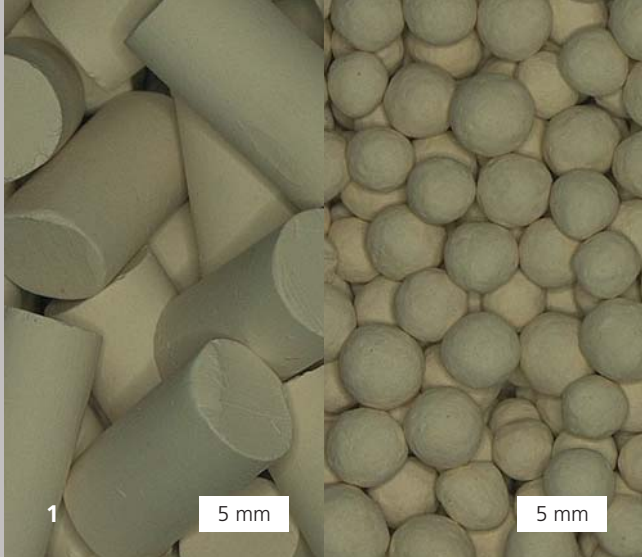

METAL-COVERED PELLETS – MATERIAL COMPOSITES FOR HEAT STORAGE

Dipl.-Ing. Heike Heymer, Dipl.-Krist. Jörg Adler

Bulks from commercial catalyst and sorbent pellets (e.g. zeolite or activated carbon) have a low thermal conductivity and mechanical stability. For that reason, it is the aim of a strategic Fraunhofer project with Fraunhofer IWU and IGB to develop pellets with high inner porosity and specific surface area as well as good mechanical stability. In a fixed-bed reactor, these pellets are expected to have significantly better thermal conductivity values than standard pellets. Furthermore, a manufacturing method is to be developed which allows for fast and cost-effective mass production.

One solution is to cover the sorbent or catalyst powder of the preferably cylindrical pellet with a good heat-conducting material such as copper or aluminum. Due to this metal shell, the pellets have a high wear resistance and fracture toughness when transported or filled into the reactor. Good thermal conductivity results from the surface contact of the pellets as the highly heat-conducting shells form a good heat-conducting skeleton.

The flow chart below, worked out in collaboration with Fraunhofer IWU, shows the manufacturing process of such pellets.

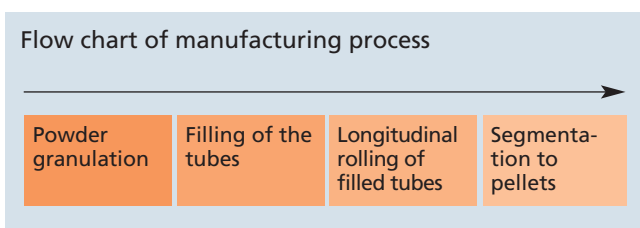

After a suitable powder has been granulated, it is filled into prepared Al tubes (e.g. with a diameter < 4.5 mm) by means of a filling apparatus. Afterwards, the filled tubes are reduced in diameter by longitudinal rolling. So, the granulate is fixed in the metal shell by compaction. Then, the tubes are cut to the desired length resulting in pellets.

A NaY zeolite from Chemiewerk Bad Köstritz GmbH with aluminosilicate (1) or silicate (2) binder was chosen as model substance. In preliminary tests in which the powders were granulated and uniaxially pressed to small cylinders ($D = 10 \text{ mm}$, $H = 10 \text{ mm}$) the influence of the degree of compaction on stability and specific surface area was studied. As expected, the increasing compaction pressure positively influences the green densities ($0.66\text{--}0.8 \text{ g/cm}^3$) and thus also the compressive strength of the cylinders ($1\text{--}2.5 \text{ MPa}$). After compaction and annealing, the specific surfaces of both binder types tested show only slightly lower values than the starting granulates. The difference to the starting powder CBV100 is adequate to the binder content.

Furthermore, the filling and flow behavior of the granulates (1) and (2) was investigated using filling and vibration tests in prepared Al tubes. Approx. 70 % of the compaction density of 10 MPa compaction pressure was achieved using suitable vibration parameters. However, this is not sufficient to fix the granulate in the tubes. First tests, in which the filled tubes were rolled additionally, showed that a reduction to a diameter of approx. 3.7 mm is sufficient to compact the granulate in the tube (density of powder in the Al tube 0.66 g/cm^3) so that it is fixed and can be cut to a pellet length of e.g. 10 mm.

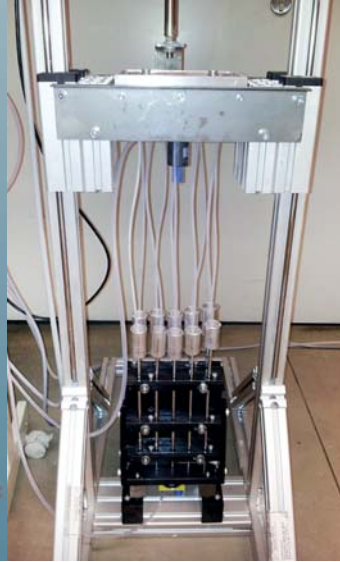

Within the framework of the project, the properties of the coated pellets are to be examined in terms of their flow and compaction properties, wear behavior, and applicability in a model heat accumulator (at Fraunhofer IGB). These tests are conducted in comparison with standard pellets and spherical granules.

The resulting additional costs as compared to standard pellets are a very important criterion for the applicability of the composite pellets. For this reason, the manufacturing costs are estimated for an industrial production process.

Services offered

- Development of composite materials for sorbent and catalyst applications
- Development of manufacturing methods for industrial production of the composites
- Application tests

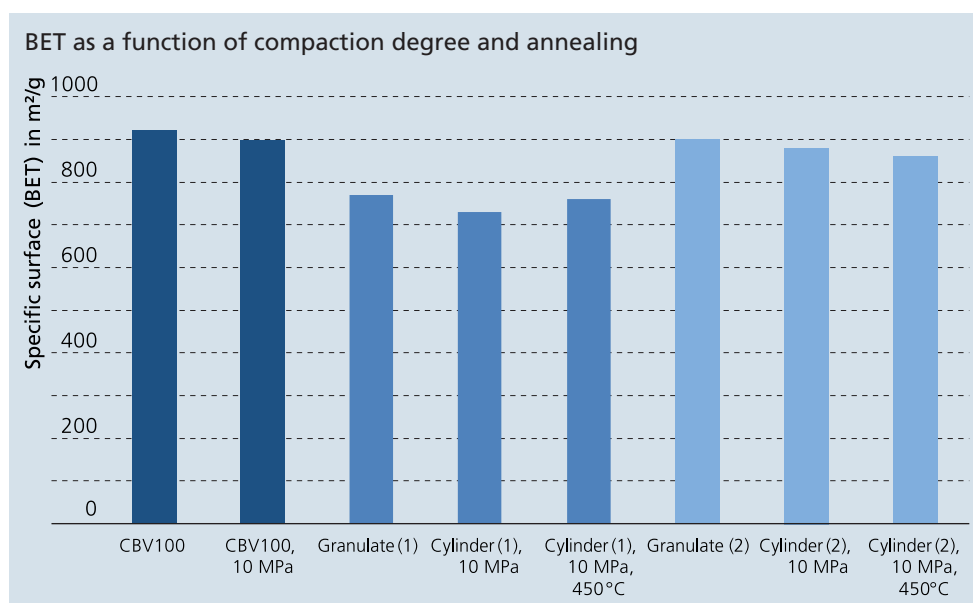

- 1 Pellets made of zeolite (Fraunhofer IKTS).
- 2 Al and copper-coated zeolite pellets (Fraunhofer IKTS).
- 3 Filling apparatus for ten metal tubes (Fraunhofer IWU).
- 4 Test stand "Sorpative heat accumulator" (Fraunhofer IGB).



SYNTHESIS AND CHARACTERIZATION OF RARE EARTH-DOPED PHOSPHORS

Dr. Katja Wätzig, Dr. Isabel Kinski

Phosphors for lighting and light emission diodes (LED) are based on the principle of photoluminescence. Colors similar to daylight can be achieved by different set-ups of the lighting source. One way is to excite blue, red and green phosphor by UV light (principle of energy saving bulb). Another possibility is to combine a blue semiconducting diode with a yellow phosphor (principle of LED) which is displayed in the schematic drawing below.

Ceramic phosphor materials can be synthesized on different synthesis routes. Traditional photoluminescent oxides such as

rare earth-doped earth alkali aluminates e.g. $\text{SrAl}_2\text{O}_4:\text{Eu}/\text{Dy}$ (afterglow) or $\text{BaMgAl}_{10}\text{O}_{17}:\text{Eu}$ (blue phosphor) are synthesized using sol-gel synthesis and solid-state reaction. Afterglow phosphors are used for labeling of emergency exits while blue, green, red and yellow phosphors are used in energy-saving bulbs or LED. For fluoridic materials, solvothermal or hydrothermal synthesis techniques are applied in teflon-lined pressure bombs. Hexagonal NaYF_4 is one of the most efficient host materials for green ($\text{Yb}^{3+}/\text{Er}^{3+}$ codoping) and blue ($\text{Yb}^{3+}/\text{Tm}^{3+}$ codoping) phosphors used in up-conversion. It is applied, among others, in healthcare.

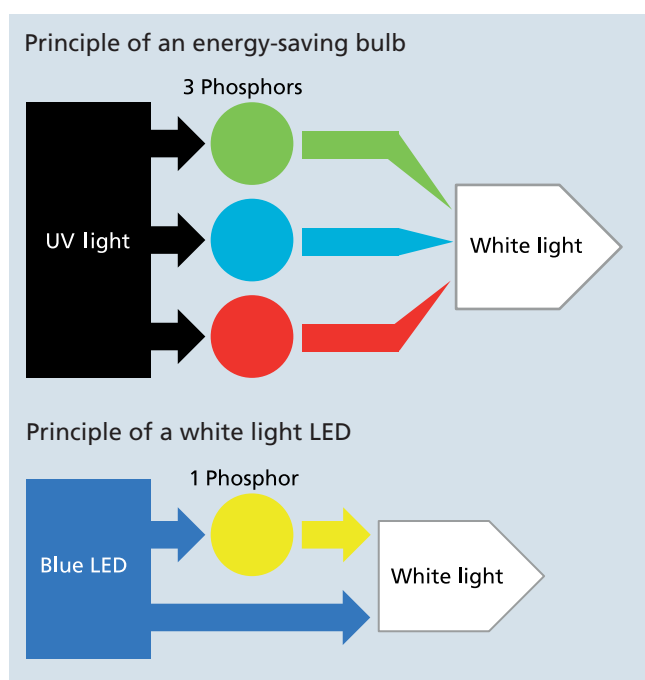

One of the main research topics deals with the synthesis and characterization of doped yttrium-aluminum garnet (YAG, $\text{Y}_2\text{Al}_5\text{O}_{12}$) which is used as yellow phosphor in white LEDs. Figure 3 shows a YAG powder which emits white light upon excitation with a blue laser light. This YAG powder might be used as starting material for optical ceramics which can serve either as laser or as LED material in dependence of the incorporated active doping ions. The diagram on the right shows the measured excitation and emission curve of semitransparent YAG sintered bulk ceramics. The excitation of these opto-ceramics by blue laser light (wavelength of 460 nm) leads to a diffuse scattering of white light through the ceramics as shown in Figure 4.

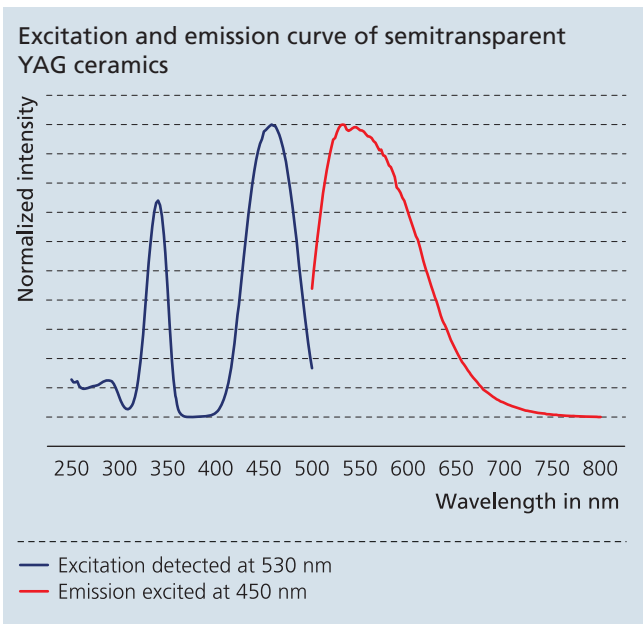
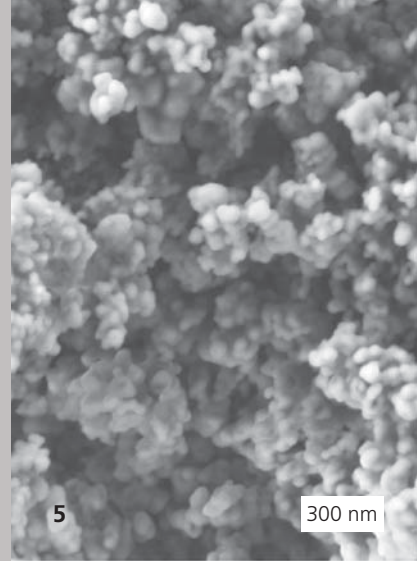

- Measurement of layer thicknesses and refractive index of (semi)transparent layers and bulk materials
- Measurement of surface tension of liquids and surface energy of solids

Services offered

- Synthesis of oxidic, nitridic, oxynitridic and fluoridic phosphor powders from nanoscale to microscale
- Synthesis of (semi)transparent optical sintered materials
- Characterization of fluorescence (measurements of photoluminescence at ambient temperature in an excitation range of 250 to 850 nm and an emission range of 250 to 1500 nm, measurements of decay time in μs)
- Sol-gel methods and synthesis of metal-organic precursors to prepare nanoparticles
- Hydrothermal and solvothermal synthesis in Teflon coated autoclaves
- Development of hard masks and protective layers
- Deposition of functional layers by PECVD in pilot scale
- Spin and dip coating, also under inert atmosphere
- Pyrolysis in inert and reactive gases

- 1 Ceramic green body at daylight.
- 2 Ceramic green body at UV excitation.
- 3 White-emitting YAG powder at blue light excitation.
- 4 White-emitting semitransparent YAG ceramic at blue light.
- 5 FESEM image of a doped, yellow-emitting YAG powder.

RESEARCH FIELD

PROCESSES AND COMPONENTS

Department head:
Dr. Hagen Klemm

Profile

The research field "Processes and Components" encompasses manufacturing processes for ceramic components and assemblies. Prototype solutions are generated on laboratory and pilot scale, small batches are produced and, if required, scaled up to pilot technologies. The value chain ranges from modification of commercial powders and raw materials to shaping, sintering, machining (green and sintered bodies), and to joining and integration technologies. The equipment enables scale-up of all individual technological processes to industrial standards, readily transferrable to the customer's site.

Design of ceramic and metallic materials as well as composite materials and their precursor products form the heart of our powder technology. Silicate and polymer ceramics are additional core areas of materials expertise. Our component design group employs a broad range of plastic and thermoplastic shaping and casting technologies as well as powder pressing. Component surfaces are treated using plasma spray processes.

The technology chains are completed with a capable and innovative green machining and finishing center. Our high standard of quality is supported by a first-class QM system and numerous certifications and expert audits.

Overall, the research unit offers outstanding possibilities for component manufacturing, system integration, and advanced materials. Prototypes and small batches can be delivered quickly, reliably, and cost effectively. We offer a flexible handling and rapid response in order to help our customers to reduce the time to market.

Services offered

- Development of ceramic processes, components and systems on a pilot scale
- Contract research and joint projects
- Services related to manufacturing processes
- Technology transfer
- Design of scientific equipment
- Feasibility studies
- Consulting and training courses

In conjunction with other research fields at Fraunhofer IKTS, namely materials development and simulation, we offer competent advice and excellent R&D to our partners. We can draw on the expertise of other institutes in the Fraunhofer AdvanCer Alliance to extend our scope.

www.advancer.fraunhofer.de



Department head

Dr. Hagen Klemm
Phone +49 351 2553-7553
hagen.klemm@ikts.fraunhofer.de



Powder Technology

Dr. Manfred Fries
Phone +49 351 2553-7810
manfred.fries@ikts.fraunhofer.de



Finishing

Mst. Matthias Nake
Phone +49 351 2553-7586
matthias.nake@ikts.fraunhofer.de



Shaping

Dr. Tassilo Moritz
Phone +49 351 2553-7747
tassilo.moritz@ikts.fraunhofer.de



Process Technology and Silicate Ceramics

Dipl.-Chem. Gundula Fischer
Phone +49 36601 9301-1850
gundula.fischer@ikts.fraunhofer.de



Component Development

Dipl.-Ing. Jens Stockmann
Phone +49 351 2553-7561
jens.stockmann@ikts.fraunhofer.de



CERAMIC MATRIX COMPOSITES BY INJECTION MOLDING OF SiCN PRECURSORS

Dipl.-Ing. Axel Müller-Köhn, Dr. Tassilo Moritz, Dr. Hagen Klemm

Ceramic matrix composites (CMC) are a class of lightweight materials, which are characterized by outstanding properties in terms of e.g. temperature stability, damage tolerance and low densities. Despite these superior material properties, CMC materials are rarely used in industrial applications, because they can only be produced by very time-consuming and expensive manufacturing processes.

New cost-effective manufacturing methods for CMC were developed within the framework of a Fraunhofer internal project (MAVO) in cooperation with three Fraunhofer institutes (ISC, IWM, IPK) in order to open new markets for the application of CMC.

The shaping of short-fiber CMC by injection molding is a possibility to reduce the processing costs since the fabrication of components in complex geometry and large quantities with high product quality can be realized. Furthermore, matrix assembly of CMC is already carried out during shaping as polysilazanes are used in the injection molding feedstock. In this way, multiple iterative process steps for matrix assembly (e.g. polymer infiltration and pyrolysis, PIP) can be minimized.

The processing of the raw materials to a stable feedstock suitable for injection molding was a special challenge in the project. Organic precursors based on polycarbosilanes or polysilazanes are very reactive with air and humidity. Furthermore, polymerization processes can occur during feedstock preparation at temperatures between 120 and 180°C. For that reason both, the reproducible preparation and processing of stable injection molding feedstocks were difficult. The reac-

tivity of the silicon precursors was minimized by adding functional polymers like plasticizing agents and lubricants so that significant changes in the feedstock were avoided during the processing in air.

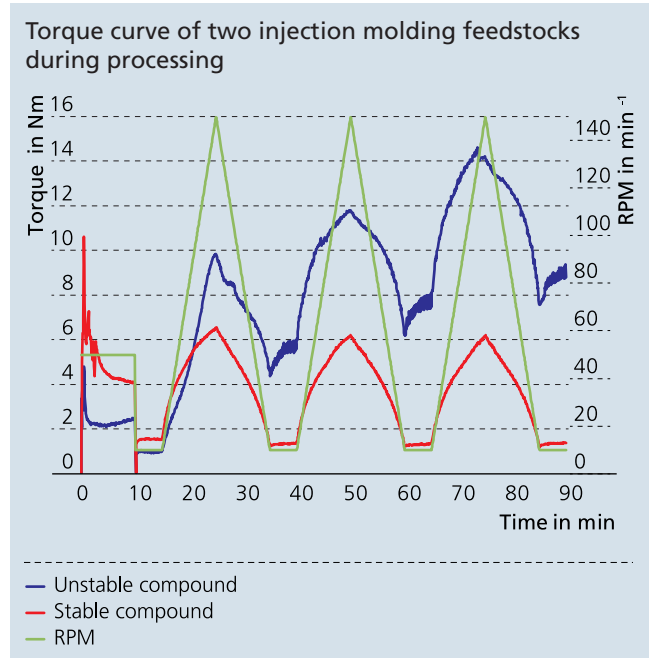

Furthermore, it is to be considered that the ceramic short fibers might be damaged (reduction of fiber length) during plasticization and homogenization of the plastic compound. However, optimal processing technologies in a twin-screw extruder provide a high potential to obtain fiber lengths of about 1 mm in the composite.

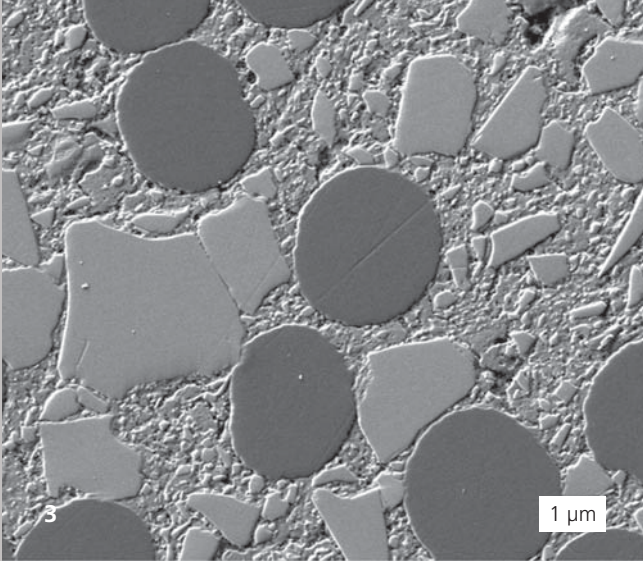

Short-fiber composites based on carbon and silicon carbon fibers were manufactured. Polycarbosilanes developed by Fraunhofer ISC and a commercial SiCN precursor (Clariant International Ltd) were used as organic silicon based polymers. Ceramic powders with various grain size distributions (SiC, Si₃N₄) and silicon powder were additionally applied as filler material.

The different injection molding compounds were comprehensively characterized in terms of their rheological properties in a high-pressure capillary viscosimeter after fabrication. Furthermore, important information for optimization of the injection molding process could be obtained by mold filling simulations of the feedstock.

Test bodies in different geometries (disks, comb structure, bending bars) were injection molded. The high potential of this technology was shown by a turbo charger prototype developed as demonstration sample.

The debinding process of the organic additives and the pyrolysis of the precursor were carried out in the next step. The green bodies obtained were characterized in terms of their density, porosity and microstructure. Caused by the use of silicon organic precursors in the thermoplastic injection molding binder the ceramic matrix between the short fibers has already been developed during pyrolysis after injection molding. In this way, it was possible to obtain CMC green bodies with consid-

erably improved green density as compared to pressed or conventionally injection molded green bodies (< 60 vol % green density). Typical examples for these materials are summarized in the table on the left.

According to the requirements resulting from the different applications, the semi-finished products are further processed after pyrolysis. Various model materials were manufactured by nitridation of the silicon containing feedstock, liquid silicon infiltration (LSI) or polymer infiltration and pyrolysis (PIP). Materials with a residual porosity of less than 10 vol % were obtained after the green body has only once been infiltrated with a SiCN precursor. The strength level of these materials was found to be in the range of 70 MPa (4-point bending). The material will be further improved by a defined matrix development for increased strength and by the use of coated fibers in order to obtain composites with improved damage tolerance.

Services offered

- Development of cost-effective technologies for ceramic fiber composites (CMC)
- Development of damage tolerant CMC according to the application requirements

Composition	Relative density	
	After pyrolysis	After one infiltration step
50 vol % Binder 25 vol % C fibers 25 vol % SiC	75 %	82 %
50 vol % Binder 17 vol % C fibers 33 vol % SiC	81 %	89 %

- 1 Test geometries after injection molding.
- 2 Turbo charger based on C fiber-SiCN composite manufactured by injection molding.
- 3 Microstructure of short-fiber CMC based on C fibers and SiCN matrix.

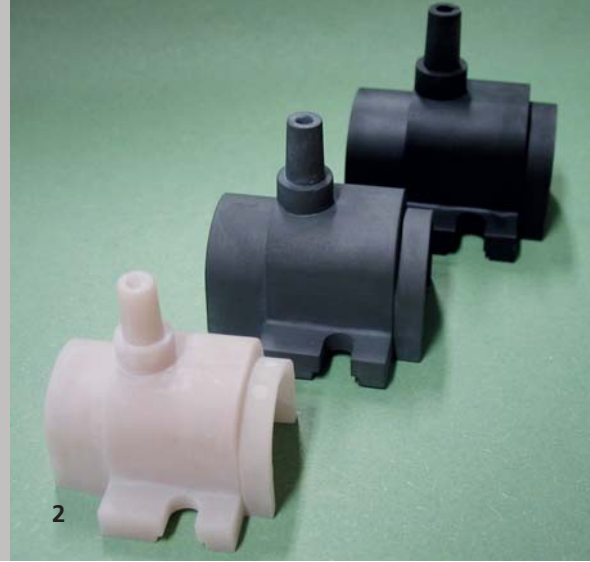
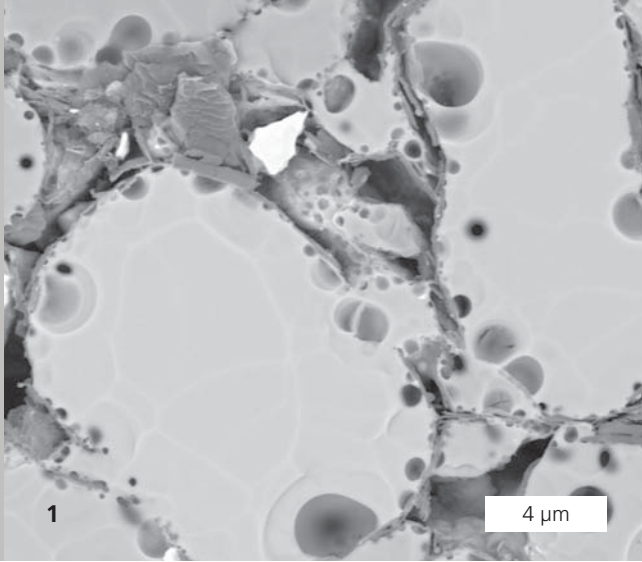

CONDUCTIVE GLASS-CARBON COMPOSITES

Dipl.-Ing. Anne Mannschatz, Dr. Tassilo Moritz, Dipl.-Ing. (FH) Maik Peschel, Dr. Jochen Schilm

Power resistors are electro-technical components which are designed to dissipate substantial amounts of electrical energy. Applications involve frequency inverters for braking systems in engines, current limiters to compensate inrush currents, but also damping resistors in resonant circuits. The dissipated energy is converted into heat by ohmic losses. Thus, properly designed power resistors can be applied as heating element. Today, metal-based wire wound resistors or devices based on pure carbon materials usually fulfill these tasks. Since the specific conductivity of the known metal resistor materials is nearly invariant, material and dimensional requirements (also for passive cooling elements) might be high, especially for high power applications. Glass-carbon composites are a promising alternative consisting of an insulating glass matrix with dispersed graphite, carbon black or carbon nanotubes as conductive phase. In this way, the specific resistivity can be adjusted to the desired application.

In traditional glass production, the glass is melted and shaped by drawing, blowing, rolling or casting. On the one hand, this requires high temperatures and energy consumption, and on the other hand, the variety of shapes is limited since sharp edges have to be avoided in the components design. Such structures can only be realized by expensive grinding techniques. Powder injection molding, however, is exceptionally well suited for complex components as it is a near-net-shape manufacturing method. The molded parts attain their final properties during thermal treatment well below the melting temperature when the powder particles sinter.

For achieving an injectable feedstock, the glass powder and the graphite were mixed with a thermoplastic binder system and granulated. A solid loading of 57 vol % was achieved using a new developed binder system. The feedstock showed a very good flowability and processability which allowed for the complete filling of the mold cavity resulting in sharp edges. Binder removal by heat treatment is a critical step since the polymers are to be decomposed while the graphite is to remain stable. Therefore, debinding was conducted in nitrogen atmosphere resulting in a 96 % yield of the initial carbon content. The samples were sintered in air. The particles which were in contact developed sinter necks and joined into larger grains. The graphite forms a conductive network within the glass matrix.

Density and porosity depend on the particle size of the glass powder. Due to improved sinter activity, density increases with decreasing particle size. The graphite content has an important effect as well since it acts as a separation layer between the glass particles inhibiting direct contact and sintering. During compounding of the glass-carbon feedstock the graphite particles with an initial size of 6.2 μm were ground to single platelets which surround the glass particles. In comparison with dry-mixed compounds the homogeneity was improved. In this way, a finer well-distributed network was formed which lead to higher conductivities at lower carbon content. A finer matrix powder has a similar effect. Test specimens with a meander shape were contacted on both sides. The heating behavior was investigated using an IR camera. The tests revealed a homogeneous temperature distribution which depends on the cross-section.

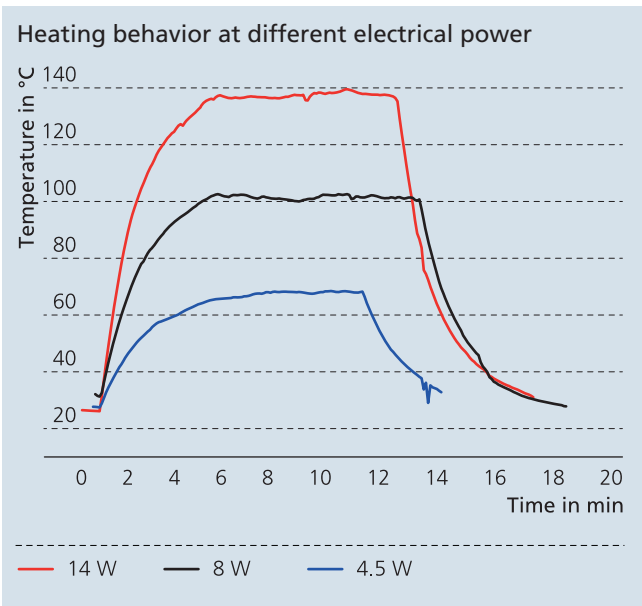
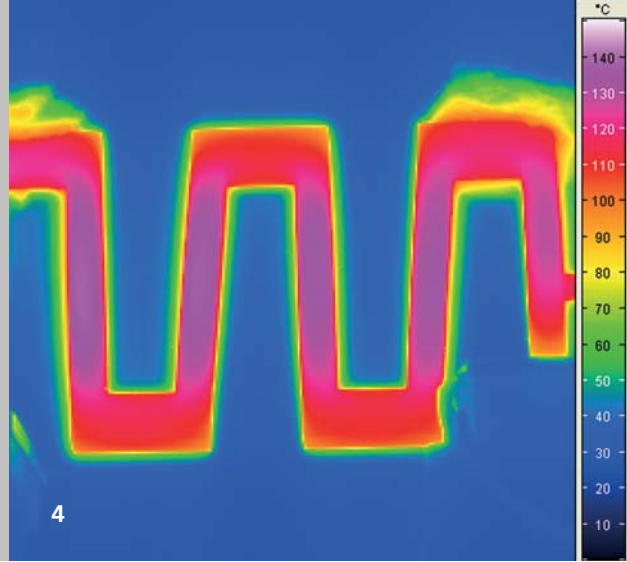

With increasing applied power the temperature increases and reaches 138°C at 14 W.

Acknowledgments

The AIF-IGF project "GlasPIM" (17231 BR) is funded by the German Federal Ministry of Economics and Technology.

Services offered

- Development of feedstocks
- Tailoring of glass-carbon composites

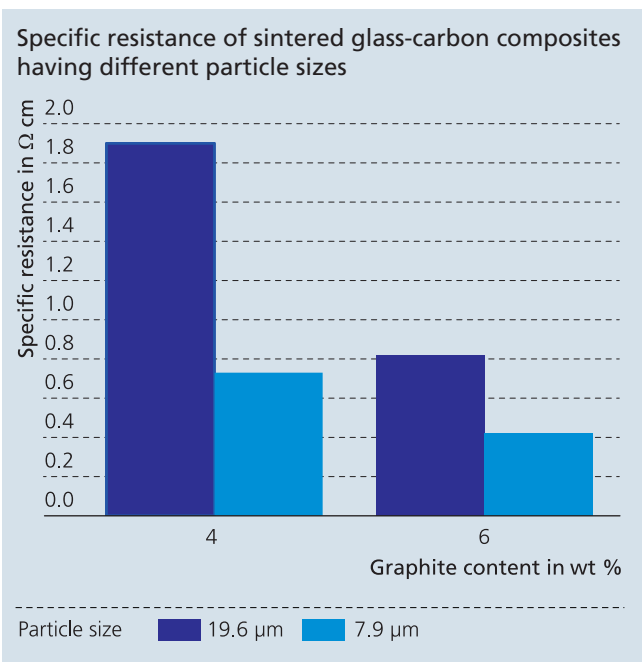

- 1 Microstructure of the composite.
- 2 Graphite-free and graphite containing glass components, design: IST METZ GmbH.
- 3 Injection molded test specimen.
- 4 IR camera image.



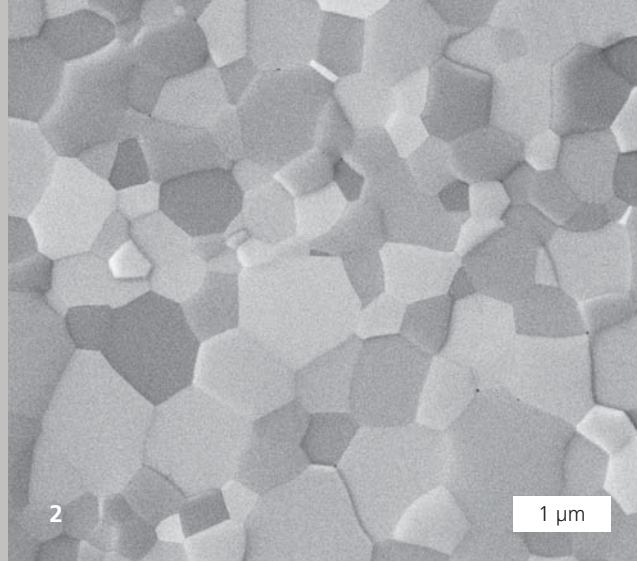
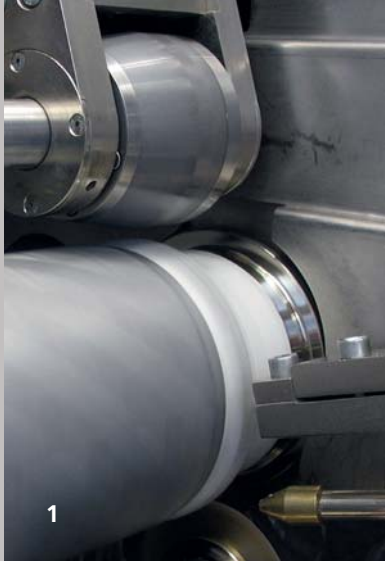

POWDER INJECTION MOLDING OF TRANSLUCENT ALUMINA

Dipl.-Ing. Anne Mannschatz, Dr. Tassilo Moritz, Dr. Jens Klimke, Dr. Andreas Krell

Translucent, i.e. semi-transparent, ceramic components are of increasing importance for many industry sectors, e.g. jewelry, watch, medical and lighting industry. Due to the shaping technologies currently applied, the geometric complexity is limited or requires time and cost-consuming machining steps in the green and sintered state. Powder injection molding (PIM) is a technology that meets the demands for complex-shaped components produced in large quantities.

For achieving translucent ceramic components, light scattering effects have to be minimized within the material. It is an essential prerequisite to realize a dense microstructure without any inclusions or pores acting as scattering centers. Due to the hexagonal crystal structure of alumina which implies birefringence, the grain size is preferably below the wavelength of visible light.

Such extreme quality requirements are challenging for any shaping technology, since any defects and especially the introduction of impurities need to be avoided. These aspects have to be thoroughly considered in choosing the raw materials. Therefore, an alumina with a high purity of 99.99 % and a mean particle size of 0.15 μm was used, which has a high sinter activity. Such small powders are a challenge when preparing an injection molding feedstock since the feedstock should possess high solid loadings and show a very good flowability and debinding behavior. Only in this way, it is possible to obtain the required high particle packing density in the green body. A homogeneous microstructure in the initial state is important for the densification process during heat treatment. A new binder system was developed taking these demands into account. So, volume loadings of 57 vol % were achieved. The second aspect is the introduction of impurities during the mixing step in compounding the feedstock. Because of the abrasive effect of the highly filled feedstock and the applied shear forces, there is the danger of wear when the feedstock comes in direct contact with metal components of the compounding machines. Therefore, the shear roll extruder was equipped with wear-resistant parts in the critical areas (Figure 1). The metal pressure roller was substituted by a pressure roller made of silicon nitride, and the granulation ring was coated with alumina. A soft material (PSU) was chosen for the cutting blade. In this way, the high-purity feedstocks were produced.

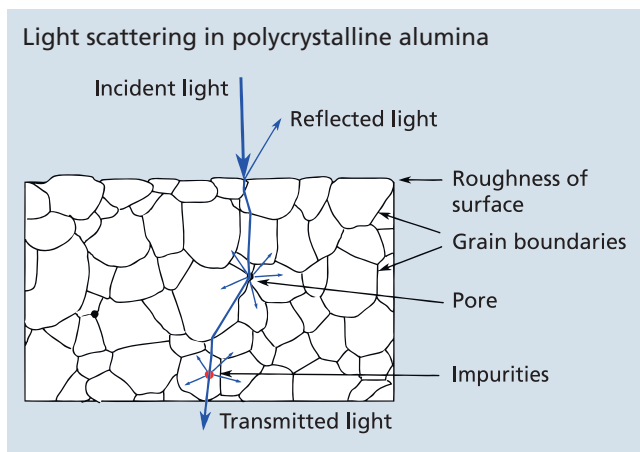



Injection molding was conducted at moderate injection pressure in order to avoid residual stresses within the green part. After debinding, the components were presintered and finally hot isostatically pressed (HIP). The sintered density was 99.8 %. The dense microstructure had only very few pores located between the grains. Grain size was within the pursued sub-micron range (Figure 2). In-line transmission was measured at a wavelength of 640 nm. It reached 36.9 % for a sample thickness of 0.8 mm. These properties allow such injection molded components to be used in medical applications or, for example, as scratch-resistant translucent consumer products such as operating buttons. A demonstrator component was manufactured for representing the field of decorative objects (Figure 4). Translucent alumina inlays were cut from a large bar-shaped sample and included into a black zirconia disk. It is illuminated by a light source from the backside.

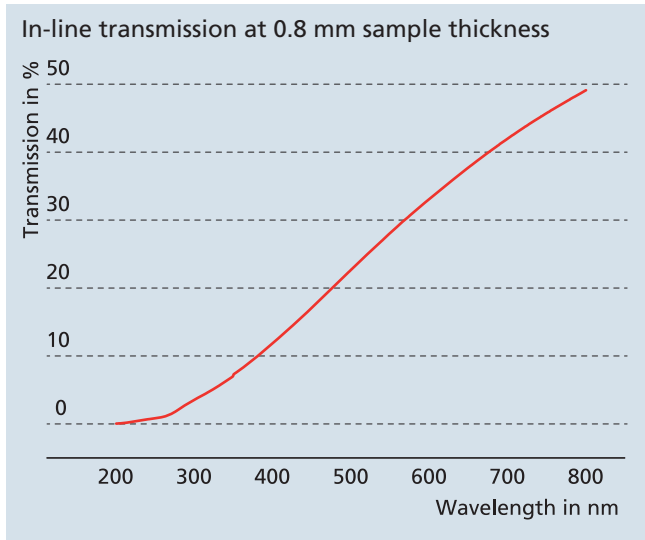

Properties of the injection-molded alumina components

Density (Archimedes method)	Porosity (Image analysis)	Mean grain size (Image analysis)
3.972 g/cm ³	0.02 %	0.72 μm

Services offered

- Development of injection molding feedstocks
- High-purity compounding of feedstocks

- 1 Wear-resistant granulation unit on the shear roll extruder.
- 2 Microstructure of translucent alumina.
- 3 Injection-molded alumina bar.
- 4 Demonstrator component.

RESEARCH FIELD

ENVIRONMENTAL AND PROCESS ENGINEERING

Department heads:

Dr. Hannes Richter

Dr. Ralf Kriegel

Dr. Burkhardt Faßauer

Dr. Matthias Jahn

DEPARTMENT

NANOPOROUS MEMBRANES

Profile

The research field "Environmental and Process Engineering" encompasses separation and reaction technology – from materials development to the construction of plants and reactors.

The department "Nanoporous Membranes" develops ceramic filters with pores in the nanometer and subnanometer range. Nanoporous ceramic membranes allow the separation of liquid, vaporous and gaseous material mixtures by filtration using the differences in size, shape or adsorption behavior.

Membrane development ranges from material synthesis, testing and manufacturing methods to sample production on an industrial-scale and the equipment of pilot plants. In membrane development, various membrane materials are produced by sol-gel technology, hydrothermal crystallization, CVD or tape casting. Due to these technologies, membranes can be produced in one-channel or multi-channel geometry, as capillary as well as flat membrane. Current research is focusing on the use of hollow fiber bundles and honeycomb ceramics as support structures.

The nanoporous membranes developed at Fraunhofer IKTS can be used for effective separation in environmental engineering (waste water treatment), the food, chemical and pharmaceutical as well as fuel industry. Furthermore, the technologies and methods of membrane preparation are used for sealing, modifying and functionalizing surfaces in the building sector as well as for vehicle components, medicine products,

tools, optical components, electronic devices and household appliances.

Services offered

- Development of nanoporous membranes and composite membranes for
 - Micro-, ultra- and nanofiltration in aqueous solutions
 - Nanofiltration in organic solvents
 - Vapor permeation/pervaporation
 - Gas separation
- Development of nanoporous membranes based on amorphous oxides, zeolites and zeolite analogues, metal organic frameworks (MOFs), carbon and carbon compounds as well as composite membranes for customer-specific separation tasks
- Development of membranes for application-specific geometries such as one-channel or multi-channel tubes, capillaries, flat membranes or honeycombs
- Manufacturing of membrane samples in industrial-scale and equipment of pilot plants
- Development of functional coatings for applications in optics, catalysis and storage technology
- Development and production of composites for large-area coating in the building sector

In cooperation with the department "Biomass Technologies and Membrane Process Technology" customer-specific separation processes are investigated, membrane separation processes developed and filtration plants are designed and built.



Department head
Nanoporous Membranes

Zeolite Membranes and Nano-Composites

Dr. Hannes Richter
Phone +49 36601 9301-1866
hannes.richter@ikts.fraunhofer.de



Carbon-Based Membranes

Dipl.-Ing. (FH) Susanne Kämnitz
Phone +49 36601 9301-1916
susanne.kaemnitz@ikts.fraunhofer.de



Membrane Prototypes

Dipl.-Ing. Jan-Thomas Kühnert
Phone +49 36601 9301-2619
jan-thomas.kuehnert@ikts.fraunhofer.de

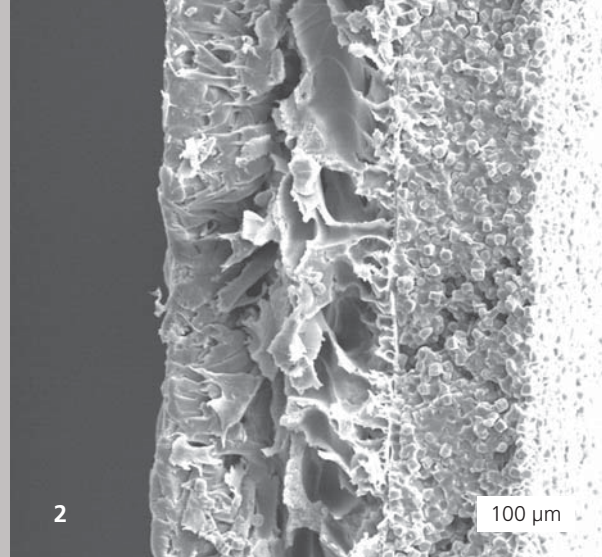
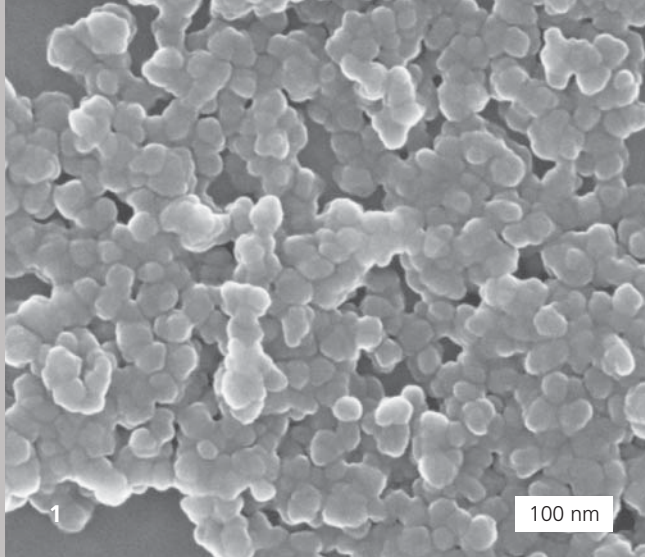

MIXED MATRIX MEMBRANES

Dr. Hannes Richter, Dr. Thomas Hoyer

Using membranes, the separation of mixtures can often be carried out more efficiently and with lower energy consumption than by thermal processes such as distillation. In addition, membrane technology is characterized by high flexibility and modular construction. Therefore, the separation process can be adapted to changing volumes and composition of industrial mixtures.

Membranes made of polymers can be produced cost-effectively in high quantities. The preparation of filtering units (modules) is not complicated, but the separation performance (selectivity, flux) is often quite low. Nanoporous inorganic membranes (zeolites, amorphous oxides, carbon) do have excellent separation performance, but are often too expensive for several industrial applications. The positive properties of both membrane materials can be combined by embedding inorganic active components into a polymeric matrix creating a composite membrane (mixed matrix membrane).

Hydrophobic zeolites (silicalite) of different particle size (50–200 nm) – prepared at the Hermsdorf branch of Fraunhofer IKTS – were embedded into silicone (PDMS) with different contents and shaped to self-supporting membranes by spreading out. Increasing flux and ethanol/water selectivity were found with increasing zeolite content during separation experiments with water/ethanol mixtures (pervaporation). So, ethanol of 70 wt % was separated from a 9 wt % solution at a temperature of only 40°C.

Separation of ethanol at 40°C from an aqueous solution of 9 wt % ethanol

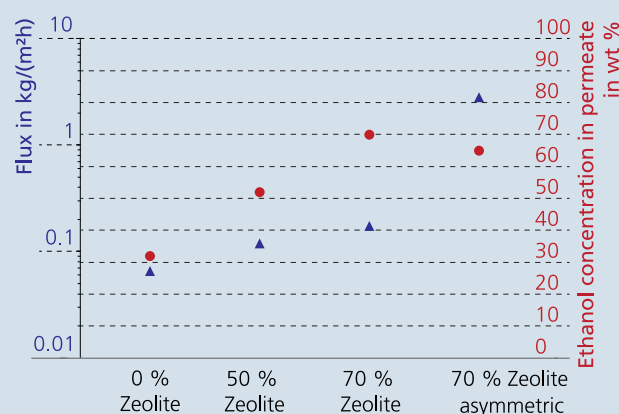

A tape drawing machine was constructed and built up for the preparation of asymmetrically structured mixed matrix membranes. Mesoporous polyacrylonitril membranes (PAN, pore size app. 50 nm) were prepared by a phase inversion method on top of a supporting tissue material. In a second step, the selective silicalite/PDMS membrane was applied on top of the PAN membrane in a thickness of 100 nm. Very high fluxes of 2.8 kg/(m²h) and an ethanol enrichment from 9–65 wt % was achieved using this type of membranes during ethanol/water separation experiments.

Because of the high flux and selectivity a fast reduction of ethanol concentration to in feed solution < 2 wt % was found when the ethanol/water separation test at 40°C was continued. Also from this low concentration 2 kg/(m²h) ethanol of 25 wt % were separated.

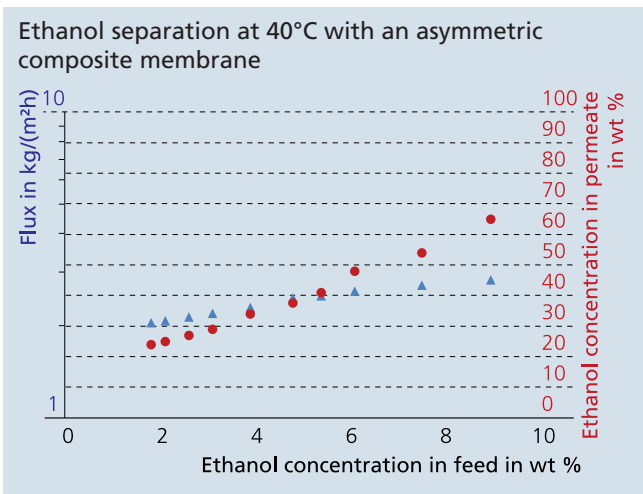
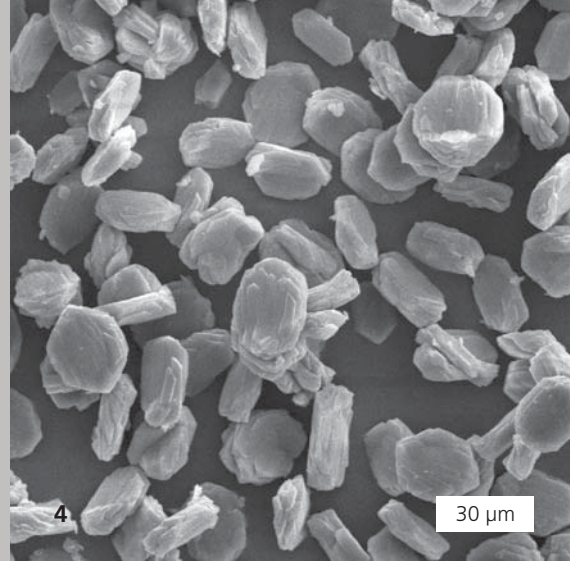

Services offered

- Membrane development for specific separation tasks
- Preparation of membrane samples in a width of 0.3 m and any length
- Preparation of sample modules
- Separation tests with customer-specific mixtures
- Separation tests in combination with customer-owned plants and processes

The embedding of hydrophilic zeolites and metal organic frameworks (MOFs) are topics of current research. MOFs are metal organic crystalline materials of zeolite structure which contain pores in the size of small molecules. Because of the organic linkers inside of this crystal structure a gapless joining of the MOFs with the polymeric matrix material is possible, resulting in membranes of excellent selectivity. The experiments are carried out with commercially available as well as self prepared MOFs.

In summary, mixed matrix membranes are characterized by:

- High flux and selectivity during the separation of mixtures
- Cost-effective production with a simple scalable tape drawing technique
- Simple module design

- 1 Synthesized silicalite nanoparticles.
- 2 Silicalite/PDMS mixed matrix membrane on PAN/tissue supporting structure.
- 3 Tape drawing plant for mixed matrix membranes.
- 4 MOF crystals (ZIF-8, Fraunhofer IKTS).

RESEARCH FIELD

ENVIRONMENTAL AND PROCESS ENGINEERING

Department heads:

Dr. Hannes Richter

Dr. Ralf Kriegel

Dr. Burkhardt Faßauer

Dr. Matthias Jahn

DEPARTMENT

HIGH-TEMPERATURE SEPARATION AND CATALYSIS

Profile

The research field "Environmental and Process Engineering" encompasses separation and reaction technology – from materials development to the construction of plants and reactors.

The department "High-Temperature Separation and Catalysis" develops materials, components and methods for gas separation at high temperatures as well as heterogeneous catalysis. Gas separation focuses on the generation of oxygen through membrane separation and storage methods using mixed conducting oxide ceramics. These energy-efficient alternatives to cryogenic air distillation and pressure swing adsorption open up various applications within the combustion (increase of efficiency, CCS), and gasification field (N_2 exclusion). They can also be used within chemical reactions (partial oxidation, oxidative dehydration). For catalytic gas reactions, mixed oxide catalysts free of precious metals are favored. In combination with gas separation in membrane reactors, these catalysts allow for a shift of the chemical equilibrium resulting in significantly higher yields.

Materials development is based on complex mixed oxides. Their application-relevant properties are widely varying. They are synthesized, characterized and processed by ceramic shaping (extrusion, dry compaction) resulting in components with an optimized geometry. Research into their transportation behavior and catalytic activity provides a data basis to simulate material behavior and the conversion rate of the used reactants. For property optimization, specific coating technologies

are used and further developed. To join the ceramic components to conventional materials, specific joining methods (RAB, diffusion bonding) are applied.

Services offered

- Customer-specific synthesis of mixed oxides of complex composition
- Characterization of oxygen permeation, storage and stoichiometry
- Shaping of mixed oxide powders to ceramic components with complex geometry
- Qualification of ceramic catalysts for partial oxidation, total oxidation, selective reactions (nitrogen oxides, halogenated hydrocarbons)
- Development of specific coatings (catalytic, protection and separation layers)
- Joining of oxide ceramic components and further development of specific joining methods
- Situation and system analysis
- Basic engineering of components and modules
- Prototyping for oxygen-permeable ceramic membranes for testing and piloting
- Consultancy on system integration of oxygen separation considering economic and energetic aspects
- Development and optimization of catalytic processes as well as gas storage and gas separation processes

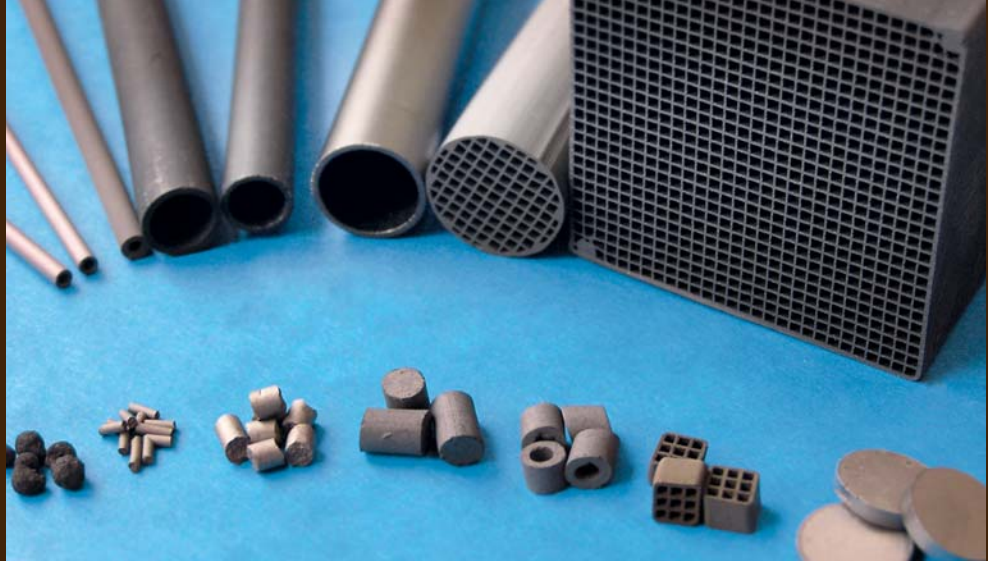

Department head
High-Temperature Separation and
Catalysis

**High-Temperature Membranes
and Storages**

Dr. Ralf Kriegel
Phone +49 36601 9301-4870
ralf.kriegel@ikts.fraunhofer.de



High-Temperature Separation

Dr. Robert Kircheisen
Phone +49 36601 9301-4870
robert.kircheisen@ikts.fraunhofer.de



Catalysis and Materials Synthesis

Dr. Jörg Richter
Phone +49 36601 9301-2327
joerg.richter@ikts.fraunhofer.de

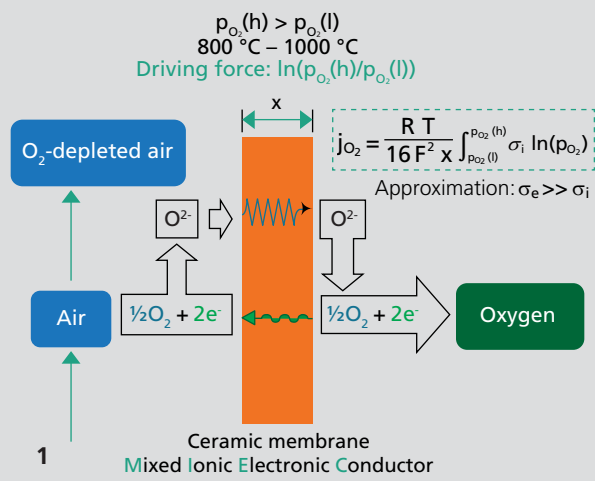

THIN ASYMMETRIC PEROVSKITE MEMBRANES FOR O₂ SEPARATION

Dr. Ralf Kriegel, Dipl.-Ing. (FH) Ute Pippardt, Dipl.-Ing. (FH) Lutz Kiesel, Dr. Robert Kirchsen

The conventional production of oxygen using cryogenic air distillation or PSA (Pressure Swing Adsorption) requires at least 0.36 kWh_{el.} per m³_STP O₂ in energy-optimized large plants. The energy consumption of small local plants is typically above 1.3 kWh_{el.} per m³_STP O₂. Storage tanks based on liquified gas or on flasks typically entail high costs due to rental fees and transportation costs. The generation of highly pure oxygen by means of ceramic membranes is an energy-efficient and economical alternative particularly for small plants.

The operating principle of the high-temperature separation process is depicted in Figure 1. It is based on combined ionic and electronic conductivity of mixed oxides with a complex chemical composition. Their material properties can be varied within a wide range by chemical substitution. Figure 2 shows such ceramic components for gas separation produced by extrusion.

Technical feasibility of the membrane separation process was demonstrated in 2009. Then, a demonstration unit was built and tested which was equipped with monolithic oxygen membranes based on BSCF (Ba_{0.5}Sr_{0.5}Co_{0.8}Fe_{0.2}O_{3-δ}) with a wall thickness of 1 mm. In vacuum operation mode, the device generated 170 L_{STP} O₂ per hour using 19 membrane tubes. Compared to commercial PSA plants, an on-site oxygen membrane plant is already competitive with monolithic membranes. A distinct increase of oxygen permeation (area-normalized oxygen flux) would further improve the economic benefits as plant size and capital costs are reduced.

For the given operating conditions and the same membrane material, an increase of the oxygen permeation can be realized by minimizing the membrane thickness. This leads to a concept of a so called asymmetric membrane, a combination of a thin separation layer with a porous ceramic support to ensure sufficient mechanical strength. For these membranes, an oxygen permeation as high as 70 ml_{STP}/(cm²·min) has already been reached. However, these values were obtained only for very small membrane areas below 2 cm². The production of asymmetric membrane components usable for technical applications has failed so far either because of the time-consuming manufacturing process or the insufficient gas-tightness of the separation layer entailed by a lack of selectivity.

At Fraunhofer IKTS, asymmetric membranes were manufactured by multiple coating of porous support tubes. These tubes were produced by combining coarse and fine powder batches resulting in a maximal open porosity of approx. 32 vol %. In order to achieve dense layers, four to five coating steps (consisting of dip-coating and sintering) were necessary resulting in unacceptable manufacturing costs.

The expensive manufacturing process was the reason to develop a co-firing technique which allows to produce asymmetric BSCF membranes within one step. The process is based on extrusion batches containing an organic pore forming agent. The green extruded tubes were directly coated with a BSCF powder suspension followed by sintering to gas-tight membranes. It was essential for the success of this co-firing technique that the shrinkage curves of the extrusion batch and the

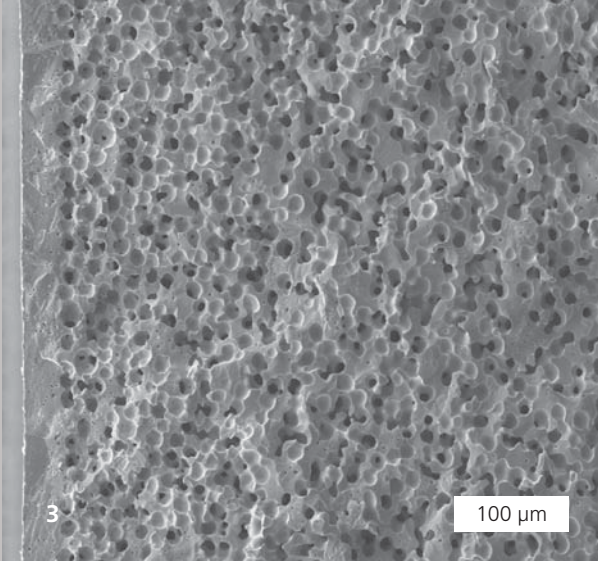

coating suspension were adjusted to each other. This was realized by an optimized powder pretreatment. Figure 3 shows a cross-section of such an asymmetric BSCF membrane. In Figure 4 whole membrane tubes with a length of 420 mm are depicted. In the diagrams below, the oxygen flux of a monolithic BSCF membrane is compared to that of an asymmetric BSCF membrane. Obviously, an improvement by a factor of 4 was achieved at comparable driving force. For that reason, a distinct decrease of the capital costs is expected for oxygen production using the membrane separation process.

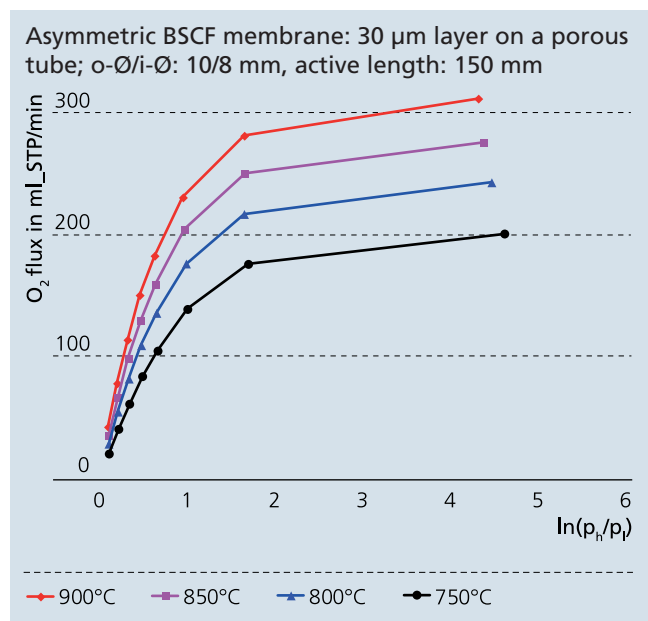
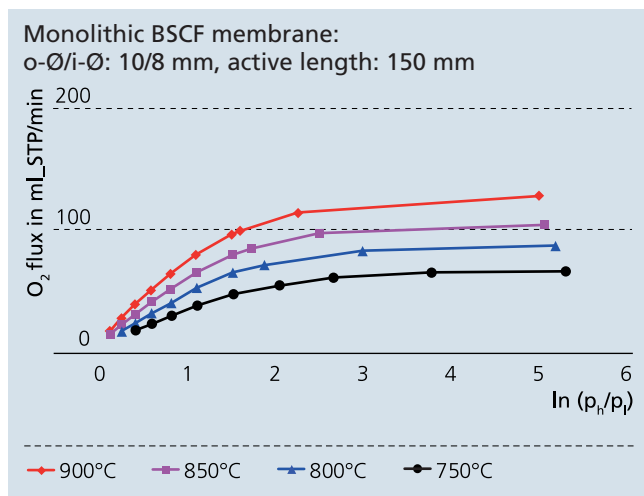

- 1 Operating principle.
- 2 Membrane components and catalysts.
- 3 SEM cross-section of an asymmetric BSCF membrane.
- 4 Asymmetric tubular BSCF membranes.

RESEARCH FIELD

ENVIRONMENTAL AND PROCESS ENGINEERING

Department heads:

Dr. Hannes Richter

Dr. Ralf Kriegel

Dr. Burkhardt Faßauer

Dr. Matthias Jahn

DEPARTMENT

BIOMASS TECHNOLOGIES AND MEMBRANE PROCESS TECHNOLOGY

Profile

The research field "Environmental and Process Engineering" encompasses separation and reaction technology – from materials development to the construction of plants and reactors.

At the core of the research activities are processes and methods for the energetic and material use of biomass, as well as the development and implementation of efficient membrane-supported separation in liquid and gaseous media. The department "Biomass Technologies and Membrane Process Technology" is involved in the planning, technical development, testing, implementation and optimization of innovative processes and aggregates for biomass conversion, as well as the treatment of municipal and industrial waste waters. Furthermore, the department optimizes mixing processes of biogenous and inorganic substrates through computational fluid dynamics. Another focus lies on the development, testing and piloting of membrane processes designed for separating liquid and gaseous/vaporous media. The department follows an integrative strategy by combining membrane processes with other working fields resulting in an increase of efficiency (e.g. generation of biogas and bioalcohols or waste water treatment). With the Membrane Technology Application Center in Schmalkalden, the Bioenergy Application Center in Pöhl as well as the laboratories in Dresden and Hermsdorf, the department has an excellent infrastructure to carry out practice-relevant studies on a pilot scale.

Services offered

- Situation and systems analysis at customer's site and in laboratory
- Substrate preparation/disintegration
- Development and optimization of processes for the generation of solid, liquid or gaseous energy carriers, e.g. from lignocellulosic residues
- Determination of gas potential of biogenic substrates
- Optimization of reaction kinetics for anaerobic breakdown processes, e.g. by selective material separation from liquid and gaseous material flows
- Analysis of mixing processes of biogenous and inorganic suspensions by computational fluid dynamics and process tomography and optimization of reactor stirring systems
- System analyses for wastewater purification and water treatment
- Concepts for waste water treatment using ceramic membrane technology, AOP processes and ultrasonic applications
- Integrated reactor systems for industrial waste waters as well as decentralized water supply and waste water treatment
- Analysis of material transport processes in membranes
- Ultrasonic application for degassing and disintegration
- Characterization of membranes
- Testing, application and piloting of membrane processes, combination of membrane processes with other technologies
- Development and prototype manufacture of membrane plants and plants for membrane testing
- Engineering of biogas plants using new, innovative process steps



Department head
Biomass Technologies and Membrane
Process Technology

**Biomass Conversion and Water
Technology**

Dr. Burkhardt Faßauer
Phone +49 351 2553-7667
burkhardt.fassauer@ikts.fraunhofer.de



**Mixing Processes and Reactor
Optimization**

Dr. Karin Jobst
Phone +49 351 2553-7827
karin.jobst@ikts.fraunhofer.de



**Membrane Process Technology and
Modeling**

Dr. Marcus Weyd
Phone +49 36601 9301-3937
marcus.weyd@ikts.fraunhofer.de



BIOGAS PRODUCTION FROM LIGNOCELLULOSIC RESIDUES

Dr. Eberhard Friedrich, Dipl.-Ing. André Wufka

Situation

Biogas is an integral part in the energy mix in the context of the German energy transition. It is versatile and makes an important contribution to sustainability and climate change. Currently, corn is still the main crop for energy production in biogas plants in Germany. The resulting increased energy crop cultivation, however, is more and more criticized. In the future, the cultivation of corn for biogas production will stagnate or see a decline which is different from region to region. Instead, alternative energy crops, in particular agricultural residues such as straw, will be increasingly used. In Germany, grain is grown on about 50 percent of the arable land. In compliance with a balanced humus content, 8 to 13 million tons of straw can be used for energy production each year. Lignocellulosic materials such as straw predominantly consist of polymeric C6 and C5 sugars (cellulose, hemicellulose) and the lignin biopolymer. Due to the material composition and the very high polymerization degree, straw is converted only very slowly into biogas. Thus, an efficient energy generation was hardly possible so far.

Approach

The challenges of straw fermentation will be encountered with an innovative process combination of mechanical disintegration and enzymatic catalysis. After or during the precomminution process by Bioextrusion® the targeted use of technical enzyme systems ensures the degradation of cellulose and hemicellulose into their monosaccharides. Commercially avail-

able enzymes and enzyme mixtures, which mainly contain β -glucanases (endocellulases and exocellulases) and hemicellulases (xylanases), are able to accelerate the degradation of cellulose and hemicellulose. These enzymes are mainly synthesized from the wood-degrading fungus *Trichoderma reesei*. For the effective utilization of the catalytic efficiency of enzyme products, the frequency of contact between enzyme and substrate must be as high as possible and the reaction conditions must be optimally adjusted. For this purpose, a separate hydrolysis step is to be developed that is run before the process step of methane formation. Testing and verification of the designed process chain for straw fermentation will be carried out on a biogas pilot plant (10 m³ reaction capacity, approx. 600 m² of technical facilities) in the newly opened Bioenergy Application Center in Pöhl (Figure 3).

Results

Enzyme preparations were tested for cellulase (endocellulase), hemicellulase and laccase. The enzyme reactions were systematically studied on standard substrates (e.g. carboxymethylcellulose) and real substrates (extruded straw). As a result, significant differences between the preparations in terms of sugar yield and conversion rate were observed. Significant release rates were achieved at temperatures of about 55°C and pH values of 4–5. The reaction conditions are optimal for hydrolysis, formation of organic acids and saturation of the solids with process fluid. Investigations on the potential biogas yield have shown that only the mechanical disintegration (Bioextrusion®) of the straw leads to a significant acceleration and in-

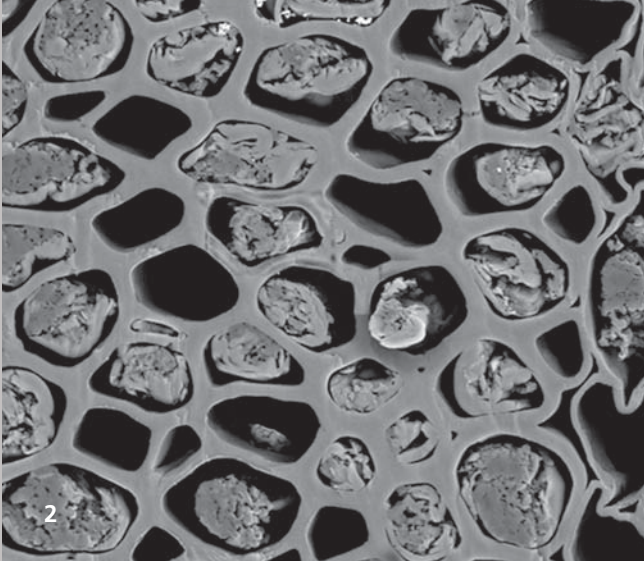

crease in the gas yield. Quasi-continuous fermentation and hydrolysis experiments as well as gas yield tests according to VDI 4630 for additional enzyme dosage show further acceleration, but methane yield cannot reliably be increased.

Summary and future research

The technical and economic feasibility of straw fermentation was demonstrated. For large-scale implementation, however, the selection and adjustment of an optimal process combination must be optimized. Low and constant initial costs as well as increased remuneration rates by the German Renewable Energy Act promote the efficiency of straw fermentation. A successful demonstration project offers a great potential for follow-up projects with value added potential.

Services offered

- Development of technologies and plants in the field of bioenergy and environmental engineering (testing and verification in the Bioenergy Application Center)
- Execution of continuous fermentation tests with customer-specific substrates and applications in pilot scale (m³ range)
- Definition and evaluation of processes for an efficient fermentation of biogenous residues

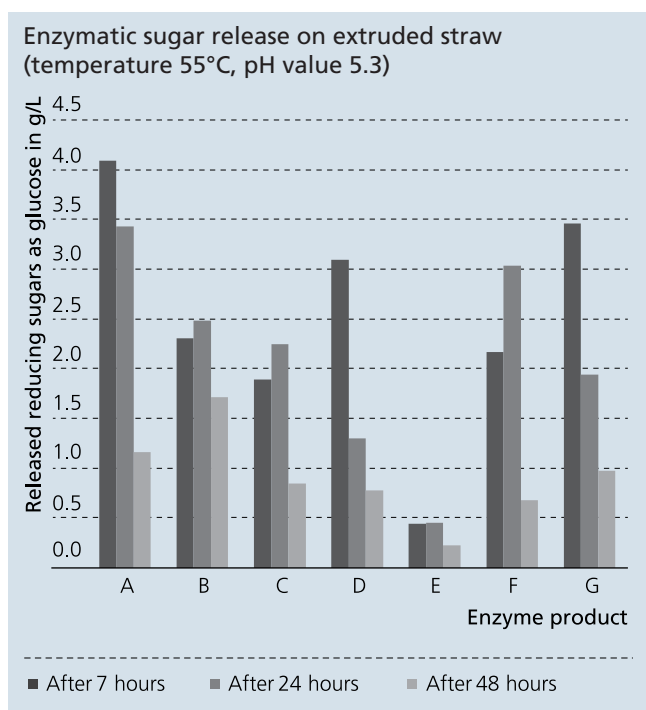

- 1 Straw harvest (round bale).
- 2 SEM image of untreated straw.
- 3 Biogas pilot plant at Bioenergy Application Center.



PRACTICAL EVALUATION AND OPTIMIZATION OF MIXING PROCESSES

Dipl.-Ing. Anne Deutschmann, Dr. Eberhard Friedrich, Dr. Karin Jobst, Dipl.-Wirt.-Ing. Annett Lomtscher

Research issue

It is difficult to analyze the mixing process in reactors especially when opaque substrates are used. Using measurement systems such as sensors and tracers the evaluation of mixing processes is locally limited. Computational fluid dynamics also lead to incorrect interpretation particularly for highly viscous, non-Newtonian fluids.

Approach

Using process tomography established at Fraunhofer IKTS a comprehensive and non-invasive evaluation and quantification of mixing processes of opaque substances can be realized. By scaling the given boundary conditions to laboratory or pilot plant scale, the mixing process can be evaluated and optimized. The true-to-scale simulation of the reactor system and the installed stirring system, the energetic evaluation and the consideration of rheological properties and granulometric parameters allow for the comprehensive evaluation, and are an interface between CFD and practice. Because of this practical relevance, optimization measures for existing biogas plants can be derived. The evaluation of mixing processes proceeds as follows:

- Characterization of the initial state
- Downscaling taking the boundary conditions into consideration
- Evaluation of the mixing process
- Variation of the boundary conditions to optimize the processes

Operating principle

An electric field is generated by high-frequency current induction inside the tomography reactor, which is influenced by the different electrical conductivities of the multiphase system. By detecting the change of conductivity, the distribution of the material systems inside the reactor can be visualized and quantified.

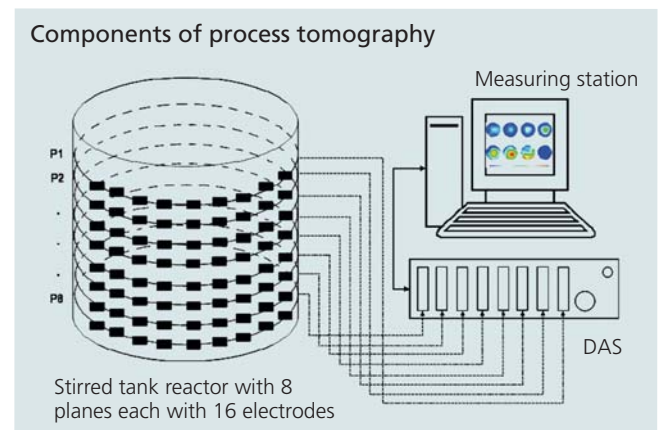

Application

Considering the reactor geometry of large-scale biogas plants, the mixing of pretreated straw into digester effluent using horizontal propeller mixers was evaluated by process tomography.

Previously conducted studies show that the actively stirred reactor volume of reactors with a height-to-diameter ratio of



about 0.5 is only 75 %. That means that the organic loading rate, which is used for the dimensioning of the biogas plants, is often exceeded. Additionally, there are large local differences in the reactor. A decline in biogas yield is a result of an insufficient mixing in the reactor. A variation of impeller speed, impeller position and geometry of the reactor should lead to an optimization of the mixing process. A substantial improvement of the mixing process was achieved only by changing the reactor geometry. Currently, it is being studied how these results influence the biogas yield.

Prospects

Continuing these studies, reliable information related with numerical fluid dynamics, evaluation of mixing processes in laboratory and pilot scale, and large-scale implementation can be derived to establish the basis for the dimensioning and operation of stirring systems especially for highly concentrated, non-Newtonian fluids.

Services offered

- Evaluation and optimization of mixing and flow processes in the field of environmental engineering, chemical industry, food industry, biotechnological processes
- Energetic evaluation and optimization
- Comprehensive characterization of substrate properties, e.g. particle size distribution, rheological parameters

Simulation of agricultural biogas plants: mixing of digestate and pretreated straw

Before addition of substrate Mixing time 60 min

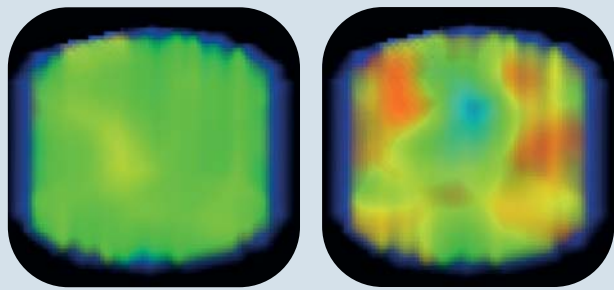

- 1 Reactor of process tomography (laboratory scale).
- 2 Reactors in pilot scale.
- 3 Mixing of treated corn silage.
- 4 Large-scale biogas plant of Lehmann Maschinenbau GmbH.



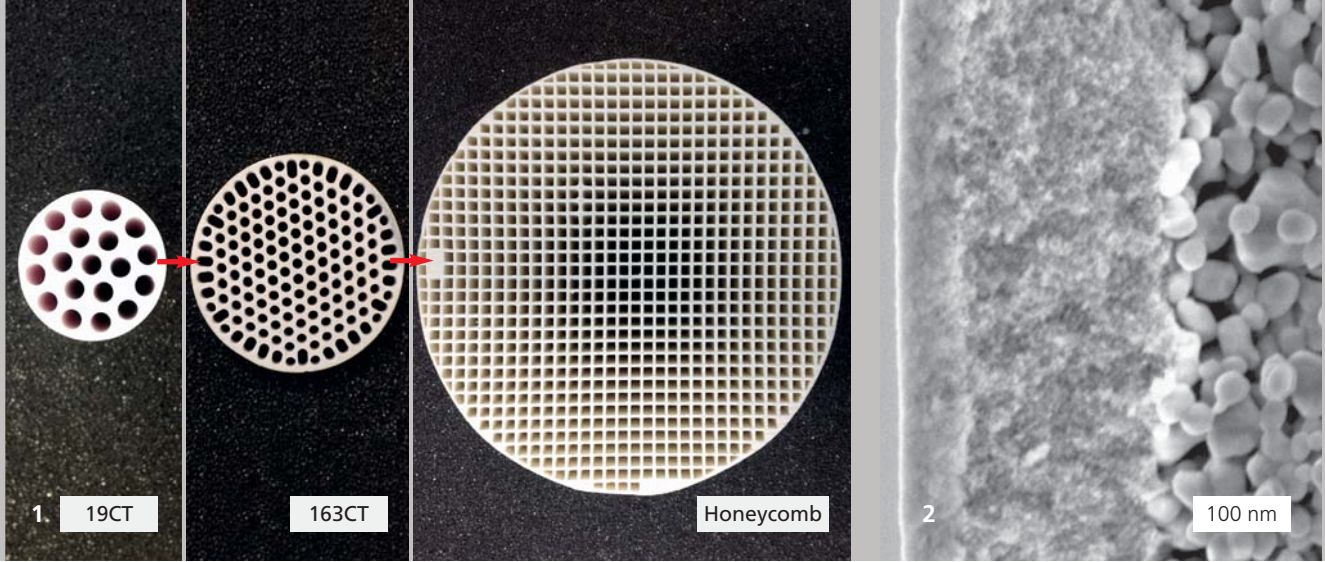

MEMBRANE AREA AND PROCESS OPTIMIZED CERAMIC NANOFILTRATION MEMBRANES

Dr. Marcus Weyd, Dipl.-Ing. Kurt Herrmann, Dipl.-Ing. Michael Stahn

Efficient membrane processes are important separation steps in environmental engineering, chemical process engineering and water treatment. In comparison to polymeric membrane materials, ceramic membranes usually show significantly higher fluxes, higher chemical and thermal resistance and high selectivity. These properties allow a wide range of cleaning techniques and sterilization of the membrane by hot steam. With ceramic nanofiltration membranes – that means ceramic membranes with a cut-off value < 1000 D – separation tasks on molecular level are possible. So, for example, dye molecules can be separated from waste waters.

The capital and operating costs are essential for a successful and economical application of ceramic membranes. Capital costs of the membranes strongly depend on the specific membrane area of the filtration elements. The higher this area is, the lower the membrane costs are and the smaller the volume of the membrane units is. This can be attributed to the production process, as each membrane element has to be individually processed. Furthermore, two seals are necessary for each membrane element to integrate it into the membrane modules. Membrane elements with high specific membrane areas will broaden the range of applications of ceramic membranes to applications that require large membrane areas such as drinking water treatment or gas separation.

The specific membrane area in ceramic membranes can be influenced by the number and shape of membrane channels. Here, the coatability of the multilayer membranes as well as the fluid dynamical properties of the membrane support have to be considered.

The complex structure and the long flow paths through the support from the feed to the permeate side of the ceramic membrane may significantly reduce the membrane area specific membrane flux.

To identify optimal membrane geometries and layer structures, simulations of mass transfer were performed using different membrane elements with different coatings. It turned out that also complicated multi-channel elements may be used very efficiently when highly porous membrane supports and nanofiltration coatings are used. So, the advantages of the large membrane area of complex membrane elements outweigh the reduced membrane area specific flux. For honeycomb elements, maximum diameters and suitable structures that allow an effective membrane process were developed.

The application of nanofiltration membranes of three different multi-channel geometries was intensely investigated. Process

Pressure gradient in ceramic ultrafiltration (left) and nanofiltration (right) membranes during permeation

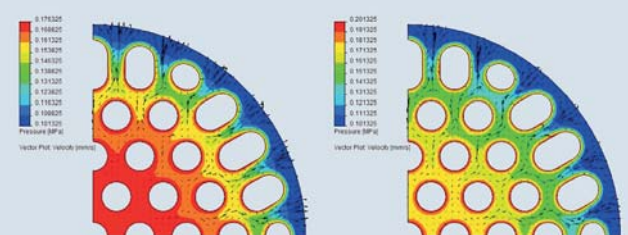

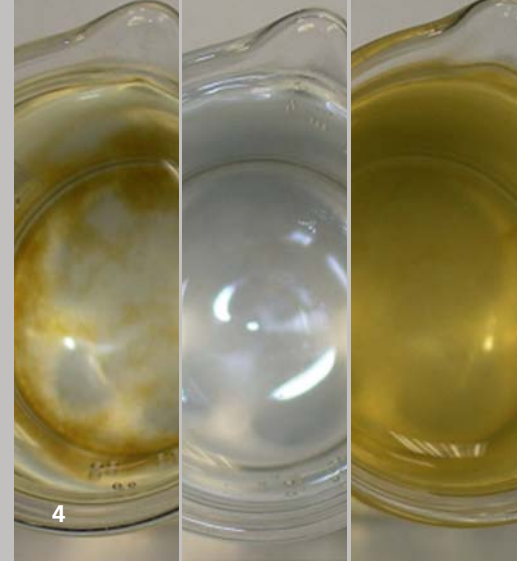

parameters were varied and energetic and performance parameters of membrane applications were determined.

Dam water was treated in a pilot filtration plant. Process parameters as well as the method of chemical pre-treatment were varied during these tests. So, it was shown that stable membrane fluxes can be achieved with a minimal dosing of flocculants as compared to conventional water treatment. These positive results were also approved when energetically optimized process parameters (cross-flow velocity, transmembrane pressure) were applied.

Acknowledgments

The European Union is gratefully acknowledged for its financial support of the "CeraWater" project (280909).

Services offered

- Customer- and application-specific membrane testing and process development
- Customer- and application-specific development of membranes and membrane supports
- Engineering, construction and equipment of membrane (test) plants
- Supply of membrane prototypes

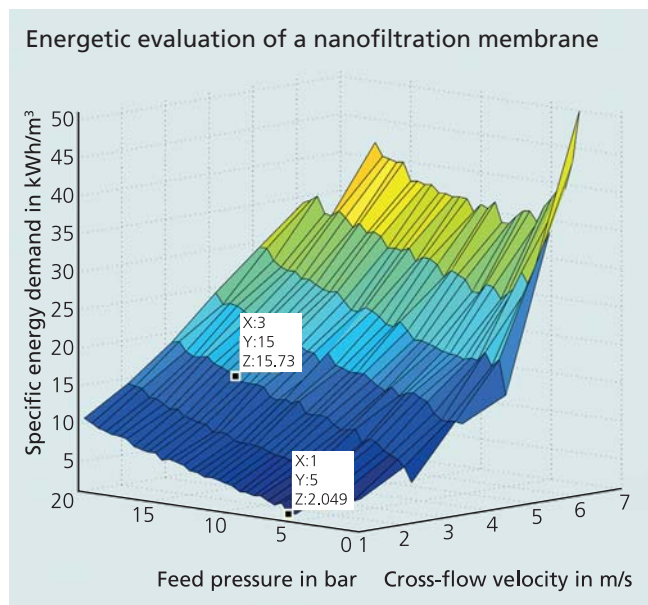

- 1 Ceramic membrane supports of different geometries.
- 2 Cross-section of a ceramic nanofiltration membrane (SEM).
- 3 Pilot filtration plant of Fraunhofer IKTS with back-flushing device.
- 4 Feed, permeate and retentate samples of dam water filtration.

RESEARCH FIELD

ENVIRONMENTAL AND PROCESS ENGINEERING

Department heads:

Dr. Hannes Richter

Dr. Ralf Kriegel

Dr. Burkhardt Faßauer

Dr. Matthias Jahn

DEPARTMENT

CHEMICAL ENGINEERING AND ELECTROCHEMISTRY

Profile

The research field “Environmental and Process Engineering” encompasses separation and reaction technology – from materials development to the construction of plants and reactors.

The working groups of the “Chemical Engineering and Electrochemistry” department develop and optimize engineering and electrochemical processes for all areas of chemical, environmental and biotechnology. Catalysts and reactors are developed in close collaboration with those groups at Fraunhofer IKTS that work in the field of materials science. Due to this collaboration, new innovative ceramic structures are applied to improve material and heat transport processes in chemical reactors as well as to intensify ceramic membrane processes. In the field of process engineering, for example, fuel cell systems with $P_{el} = 1$ kW are researched using solid oxide fuel cells developed at Fraunhofer IKTS.

Furthermore, electrode materials for supercaps and batteries for storage of electrical energy are investigated. Apart from the implementation of new materials and manufacturing technologies, their characterization and modeling are additional focal points. Extensive activities in the fields of multiphysics modeling and simulation of applications (SOFC, heterogeneous catalysis and batteries), as well as (spectro)electrochemistry are providing a methodological basis.

Services offered

- Process development and automation
- Analysis of reaction processes as well as long-term studies on degradation mechanisms in test stands and systems
- Thermal and mechanical simulation of ceramic components and devices
- Application-specific analysis of multiphysics models for functional ceramic components
- Simulation of thermal management of energy converters (fuel cells, batteries, thermoelectric generators)
- Multiphysics and CFD simulation of chemical and electrochemical processes and reactors
- Development of catalysts and reactors in the field of heterogeneous catalysis
- Process intensification using ceramic membranes and ceramic foams as catalyst carrier
- Gas analysis (FID-GC, WLD-GC, PFPD-GC and GC/MS)
- Anodic and galvanic functional layers for dielectrics, photo-voltaics, corrosion and wear protection, sensors and fuel cell technology
- Developments for high-throughput screening for applications in chemical and biochemical analysis
- Microelectrochemical and spectrochemical characterization of materials for batteries and capacitors
- Investigations on electrochemical machining (ECM)
- Investigations on corrosion and degradation mechanisms

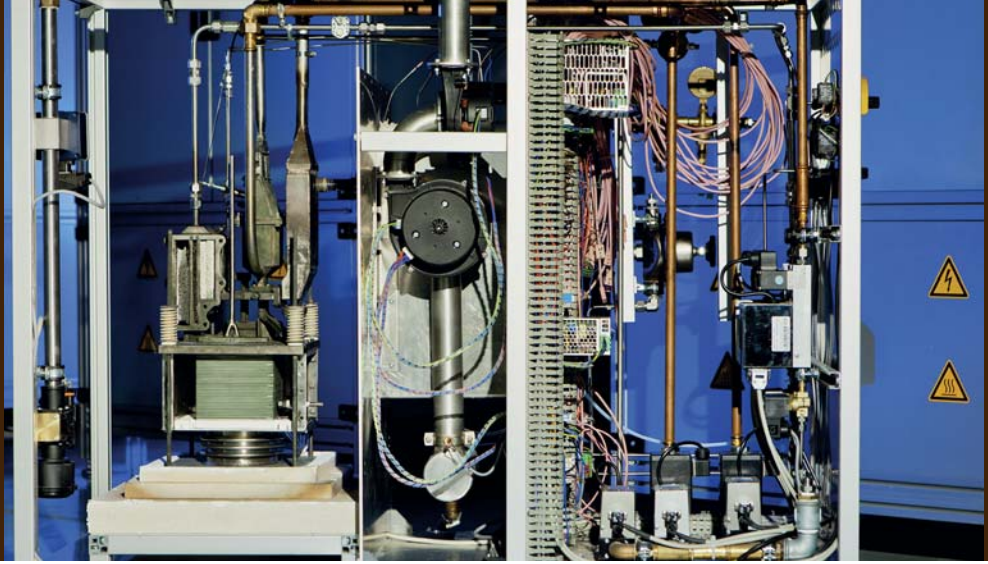

Department head

Chemical Engineering and
Electrochemistry

Dr. Matthias Jahn

Phone +49 351 2553-7535

matthias.jahn@ikts.fraunhofer.de



Modeling and Simulation

Dr. Wieland Beckert

Phone +49 351 2553-7632

wieland.beckert@ikts.fraunhofer.de



Process Systems Engineering

Dr. Marc Heddrich

Phone +49 351 2553-7506

marc.heddrich@ikts.fraunhofer.de



Electrochemistry

Dr. Michael Schneider

Phone +49 351 2553-7793

michael.schneider@ikts.fraunhofer.de

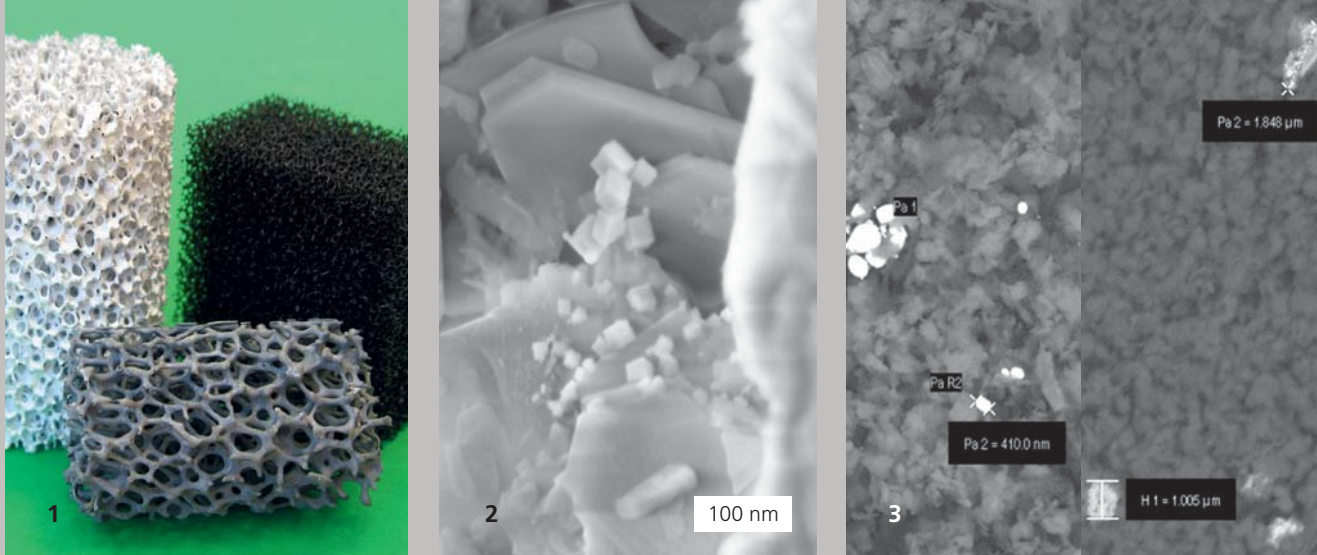

CATALYST AND REACTOR DEVELOPMENT FOR HIGH-TEMPERATURE CATALYSIS

Dr. Matthias Jahn, Dr. Marc Heddrich, Dipl.-Ing. Rico Belitz, Dipl.-Ing. (FH) Stefanie Koszyk, Dipl.-Ing. Daniela Böttge

Motivation

The use of catalytic processes at high temperature ($T = 800^{\circ}\text{C}$) leads to increased catalyst degradation. In addition, exhaust gas treatment requires long-term stability of the utilized catalysts, e.g. an operating time $t_o > 40,000$ h for stationary SOFC systems. The aim of the development efforts is to intensify the understanding of the aging behavior of various catalyst systems at this high temperature level. Combining methods of catalyst characterization and a catalyst aging model allows for target-oriented reactor design and development according to the requirements of the specific application (operating time, conversion, etc.).

Results

The decrease of the active catalyst surface is the main cause of degradation. Therefore, the attention is directed to the specific surface area of the catalyst support on the one hand, and to the distribution of the active component on the catalyst support on the other hand. Material-concerning starting point in catalyst development is the use of extrudates of substrate impregnated with active component. In exposure tests with air at high temperature ($T = 800^{\circ}\text{C}$, $t = 60$ h) their applicability in

principle is tested on the basis of the measured change of specific surface ΔA_{spec} and the active component dispersity on the support by FESEM.

Afterwards, selected material systems are applied to a ceramic foam structure. Compared to established honeycomb monolith structures these structures allow a radial cross-exchange of the gas components, and therefore a higher volume-specific conversion of the reactant gases. As a characteristic parameter for the catalyst activity of the obtained samples the temperature at a carbon monoxide (CO) conversion of 50 % (T_{50}) is determined. The T_{50} parameter increases with aging. This is followed by a series of aging steps in air ($T = 800^{\circ}\text{C}$, $t = 200\text{--}2000$ h) in turn with the determination of T_{50} .

In reactor development CO conversion in dependency of residence time can be used to characterize the catalytic function. With the decrease in catalyst activity due to aging, a progressive decrease in CO conversion for a given value of residence time can be ascertained. With the deactivation process identified in this way, the minimum residence time for the required conversion at the aged condition e.g. at $t_o = 40,000$ h can be provided for a thorough reactor design.

To model the deactivation process, kinetic parameters of the homogeneous and heterogeneously catalyzed CO oxidation at high temperatures as well as the decrease of the active surface caused by catalyst aging are taken into account. Thus both, the outlet concentration as a function of the residence time as well as the local CO concentration profile within the reactor can be calculated in dependency of catalyst aging.

Washcoat	A_{spec} (fresh) in m^2/g	A_{spec} (aged) in m^2/g	Δ_{spec} in %
$\gamma\text{-Al}_2\text{O}_3$	199	152	24
$\text{CaO-Al}_2\text{O}_3$	79	72	10

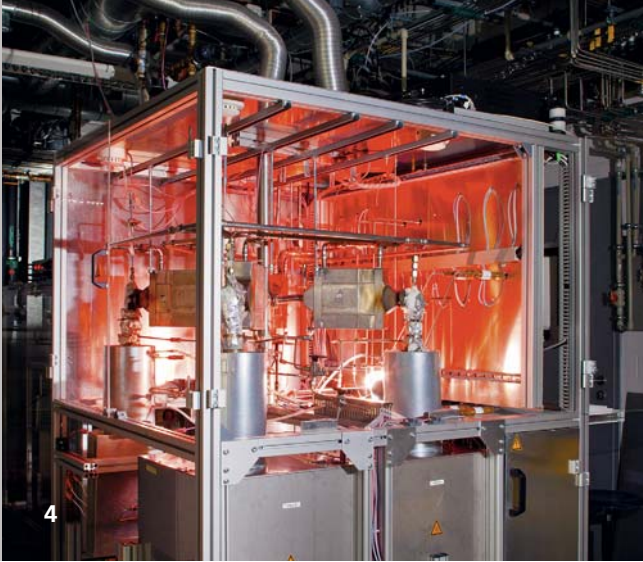

CO concentration profile (measured/calculated) regarding catalyst aging

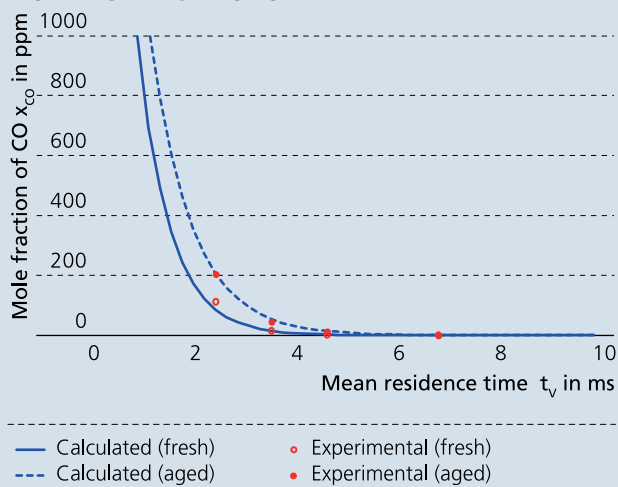

Specification – testing:

Gas mixture: N_2 75.82 vol %, O_2 16.24 vol %;
 H_2O 4.56 vol %; CO_2 1.78 vol %;
 H_2 1.02 vol %; CO 0.58 vol %
 Volumetric flow rate: $V_{tot} = 259.2$ slm
 Temperature: $T_{cat,av} = 800^\circ C$

Specification – Heat aging:

Gas mixture: Air
 Temperature: $T_D = 850^\circ C$
 Dwell time: $t_D = 200$ h

In this way, predictions of the catalyst aging process are possible, and thus the target-oriented reactor design for CO oxidation at a high-temperature level for high durability is rendered possible.

Services offered

- Catalyst manufacturing and characterization
- Gas analyses (GC/TCD, GC/FID, GC/PFPD, GC/MS, ND IR, etc.)
- Computer aided simulations of reactors (CFD), modeling of the catalyst deactivation process
- Reaction engineering analyses for component and system design
- Operating life analyses for modules and systems
- System integration for high-temperature catalysis reactors

Fields of development for long-life, high-temperature catalysis

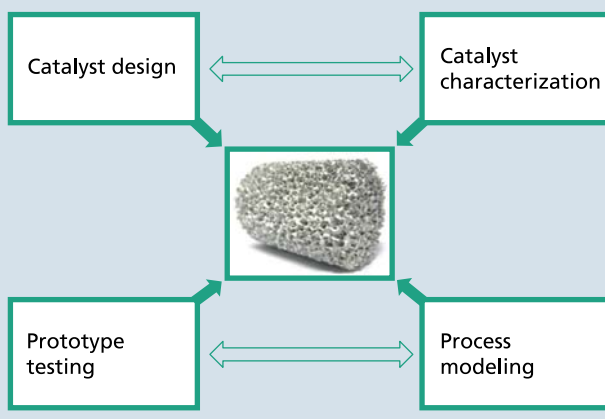

- 1 Ceramic foam (SiC) as catalyst support.
- 2 Washcoated ceramic foam (FESEM).
- 3 Dispersion of active component.
- 4 Test facility for long-term studies.
- 5 Catalytic reactor for exhaust gas treatment.

RESEARCH FIELD

SINTERING AND CHARACTERIZATION

Department head:

Dr. habil. Mathias Herrmann

Profile

Extensive sintering and analysis know-how in this research field is concentrated at both the Hermsdorf and the Dresden location. With diverse characterization methods, thermodynamic and kinetic modeling, and extensive furnace equipment from the laboratory to the pilot scale as a basis, targeted development and optimization of materials, components, and processes is performed or accompanied.

Existing methods range from particle and suspension characterization and ceramographic sample preparation using conventional and ion beam-based techniques to quantitative phase and microstructural analysis. In addition, a wide range of thermoanalytical and thermophysical characterization techniques and methods for tribological, mechanical, and electrical characterization are available. Mastery of these sophisticated analytical methods is coupled to detailed process know-how as well as materials and scientific knowledge, enabling well-founded interpretation of results.

In addition, new possibilities could be opened up for the development and application of biophysical sensor and actor systems in the last years. Systems for wireless and non-contact energy transfer were successfully developed, and their usability was proven by means of first demonstration systems (please see article on page 72).

Services offered

Development projects and individual contracts for characterization of powder metallurgical and ceramic feedstocks and materials as well as for heat treatment of materials and components:

- Particle characterization from micro- to nanoscale
- Application-specific suspension characterization for all concentrations
- Determination of thermoanalytical and thermophysical characteristics
- Investigation of sintering behavior of materials and components
- Design, execution, and optimization of heat treatments, including scale-up to industrial scale
- Characterization of materials and components in terms of microstructure, phase composition, and mechanical and tribological properties
- Testing of electrical devices and equipment (CE and GS marks, in cooperation with TÜV and VDE)
- Simulation of environmental effects (temperature, climate, mechanical loads, corrosion)
- Component failure analysis and consulting on use of ceramic materials
- Calibration of measuring devices (length, temperature, electrical measurement parameters)
- Consulting on quality and environmental management systems



Department head

**Ceramography and
Phase Analysis**

Dr. habil. Mathias Herrmann
Phone +49 351 2553-7527
mathias.herrmann@ikts.fraunhofer.de



**Thermal Analysis and
Thermal Physics**

Dr. Tim Gestrich
Phone +49 351 2553-7814
tim.gestrich@ikts.fraunhofer.de



**Quality Assurance Laboratory
and Mechanics Laboratory**

Dipl.-Ing. Roy Torke
Phone +49 36601 9301-1918
roy.torke@ikts.fraunhofer.de



Heat Treatment

Dipl.-Ing. Gert Himpel
Phone +49 351 2553-7613
gert.himpel@ikts.fraunhofer.de



**Chemical and Structural
Analysis**

Dipl.-Phys. Jochen Mürbe
Phone +49 36601 9301-4946
jochen.muerbe@ikts.fraunhofer.de



**Powder and Suspension
Characterization**

Dr. Annegret Potthoff
Phone +49 351 2553-7761
annegret.potthoff@ikts.fraunhofer.de



HYBRID HEATED FAST/SPS PLANT – DIRECT ELECTRICAL AND INDUCTIVE

Dipl.-Ing. Jan Räthel, Dr. habil. Mathias Herrmann

The FAST/SPS process is characterized by a very fast and efficient direct electrical heating and a pressure driven consolidation. During this process, heating rates of several hundreds of Kelvin and pressures of up to 100 MPa are applied. Thus, small-volume parts can be sintered very fast and in large quantities within very short cycle times. However, the consolidation of large-volume parts (especially electrically non-conductive) is a demanding task. Without a precise finite element model (FEM) and a complex tool design unwanted temperature gradients are observed in the complete component.

The diagram below shows the radial change of the β -Si₃N₄ content of silicon nitride ceramics sintered with identical parameters but different tool design. Based on this different tool

design, the radial temperature gradient was decreased and even after a short isothermal dwell time a homogeneous property distribution was achieved in the complete component. A unique and easily applicable solution to consolidate large-volume parts without changing the tool design is to use an external heating source. Therefore, the FAST/SPS was replaced by a hybrid heated system in 2012 (Figure 1).

Besides a direct electrical heating source (FAST/SPS mode), the new hybrid system is equipped with a simultaneously and independently operated induction coil. Additionally, the system can only be heated by induction to ensure a maximum of flexibility for the consolidation of various materials. The following parameters can be realized with this new hybrid system:

Change of the radial β -Si₃N₄ content using an optimized tool

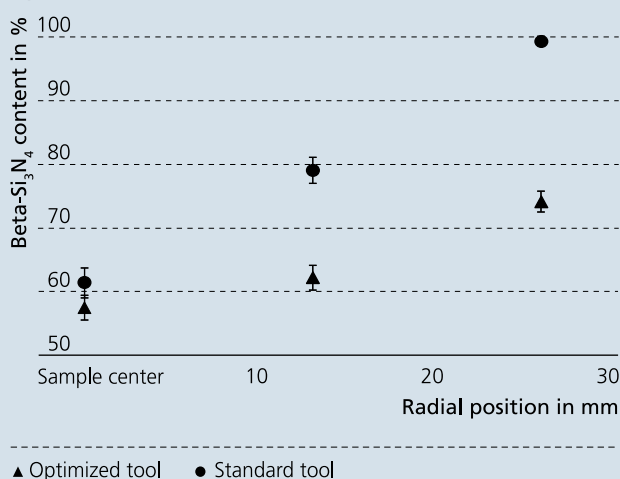

Parameter (max.)

Direct electr. heating powder	80 kW
Induction heating powder	64 kW
Pressing force	250 kN
Atmosphere	N ₂ , Ar, Vac
Tool size	100 mm

The FAST/SPS process enables the efficient and fast consolidation of several materials which cannot be produced by conventional sintering methods. For example:

- Nano-structured materials
- Functionally graded materials (FGMs)
- Transparent ceramics
- Non-equilibrium composites

Materials based on WC/Co, SiAlONs and SiC possibly including hard materials like diamond or cBN are examples for such material systems. The short process time minimizes or suppresses the phase transformation of those metastable hard phases. Nevertheless, the matrices of those composites have to be modified for such a short sintering time in order to achieve an optimum of material properties. In addition, it might be necessary to optimize the interaction between matrix and rigid inclusion for a few of those material systems despite the short sintering time. Different coatings can be established on these hard materials to support their chemical stability. Based on this aspect, Fraunhofer IKTS is working on the reproducible consolidation of such materials in order to obtain new materials with superior tribological, wear and thermal properties.

Furthermore, the hybrid FAST/SPS system allows a decoupling of electric and thermal field effects involved in the process because of the free selection of direct electrical or inductive heating. This leads to a deeper understanding of the processes taking place during this very fast consolidation, and opens new possibilities for an in-situ structuring of different materials. This also includes the generation, texturing and evaluation of new piezoceramic materials. Currently, scientists at Fraunhofer IKTS work intensively on this issue.

Another topic of research is the development of new highly wear-resistant tool materials for highest heating rates (> 1000 K/min) and shortest process times (< 5 min) for the production of small-volume parts. The high-strength isographites used as tool material so far are not perfectly suited, as they are subjected to wear under such high mechanical loads. Material systems based on nitrides, borides and carbides with a melting point far above of 2000°C can withstand such conditions and will be applied as punch and die materials in FAST/SPS tools in the near future.

Services offered

- Development of optimized sintering profiles and FAST/SPS pressing tools for your products
- Joint development of new materials, composites and components using FAST/SPS or the new hybrid heated technique and investigation of basic sintering mechanisms of FAST/SPS

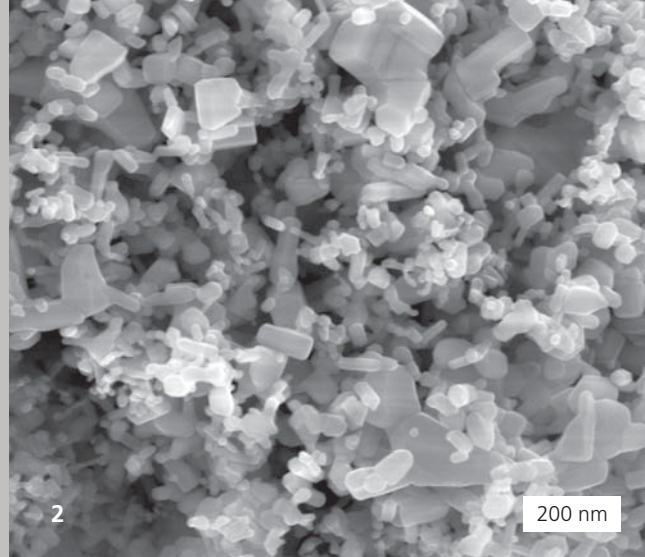
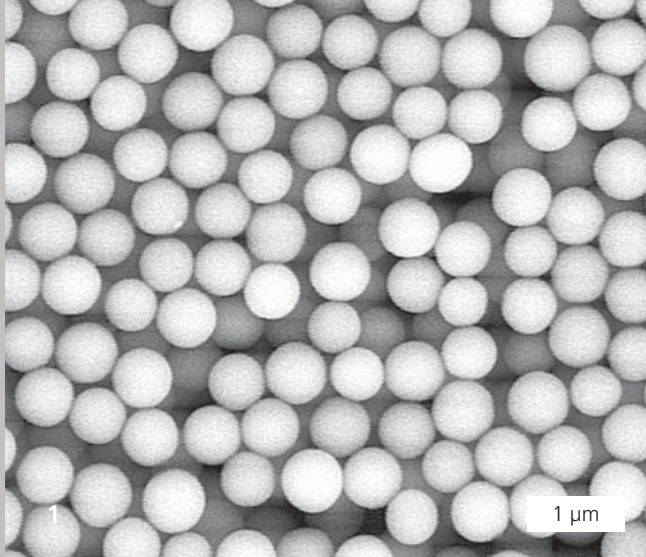

REACH – NEW REQUIREMENTS FOR THE ANALYSIS OF POWDERS AND SUSPENSIONS

Dr. Annegret Potthoff, Dr. Tobias Meißner

With the coming into effect of the new European regulation concerning the Registration, Evaluation, Authorisation and Restriction of Chemicals (REACH) in 2007, manufacturers and importers of chemicals are required to provide safety information on the substances and to register the information in a central database. Since the end of 2010, the mandatory registration of substances produced or placed on the market in quantities of at least 1000 t/a has been introduced and will be expanded to substances with production volumes of at least 100 t/a until June 2013. Substances with an annual production of at least 1 t also have to be declared until 2018.

For the registration of chemical substances at the European Chemicals Agency (ECHA), general information such as name and composition of the substance as well as data concerning the risk assessment in terms of toxicological and ecotoxicological relevance are required. A prerequisite for this is the complete characterization of the physical and chemical properties of the substance.

For materials which are produced in small amounts often only a few basic data are available, for example, on the material's dispersibility or the behavior in water. Collecting these data is a major challenge for the upcoming years.

In order to determine basic physical properties such as melting temperature or density, standards exist by which the data can be collected. For the analysis of further important parameters such as particle size distribution, suitable measurement methods have to be selected and the sample preparation has to be adapted to the specific material. Whether the material is avail-

able in the form of individual particles as required or whether these particles agglomerate depends, inter alia, on the composition of the media.

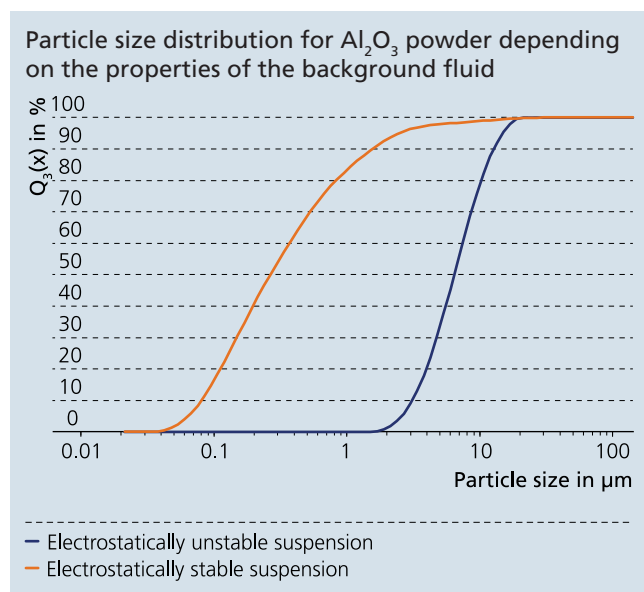

Due to their high specific surface area and their small particle size, nano-scaled materials require a further adjustment of test standards and, where necessary, the collection of additional parameters. In contrast to coarser substances, the dispersibility of the material is not only influenced by the dispersing media and specific energy input but also by the degree of aggregation.

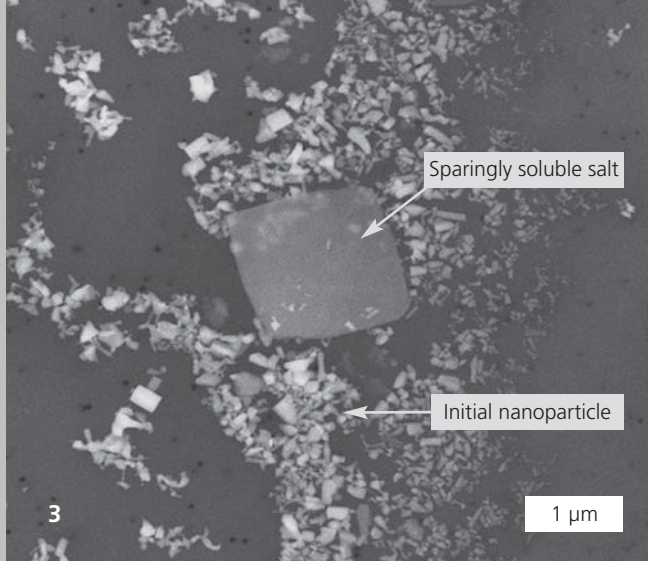

In Figure 1 and 2, a well-dispersible micro-scale material and a highly-aggregated nano-scale material are compared. After dispersing in an electrostatically stabilized medium using laser light diffraction, identical “particle” size distributions were measured although the specific surface area differs significantly.

For (eco-)toxicological studies, the materials are added to test-specific media of different composition. The behavior of the particles, for example, the degree of agglomeration, plays an important role for the interpretation of data obtained for risk assessment. Existing measurement methods were adapted in terms of sample handling and characterization so that the degree of agglomeration can be reproducibly analyzed for coarser (micro-scale) substances.

An increased dissolution can be observed for nano-scaled materials compared to micro-scaled powders. Potential interactions with further constituents of the fluid can influence the properties of the initial material, for example, by precipitation of sparingly soluble salts. The presence of initial nanoparticles next to the formed phosphate salt is shown in Figure 3. This was proved by means of EDX analysis. In case of existing crystalline phases, XRD measurements can also be used.

Using these complex characterization methods – even for previously unknown materials – the data necessary for the REACH registration can be collected. By evaluating the dispersibility, it is analyzed how the nano-scaled or micro-scaled substances behave in the test media used for risk assessment. So, the data obtained in (eco-)toxicological tests can be interpreted.

Magnetite-zeolite particle in test medium for ecotoxicological test. Partical size distribution depending on trial period

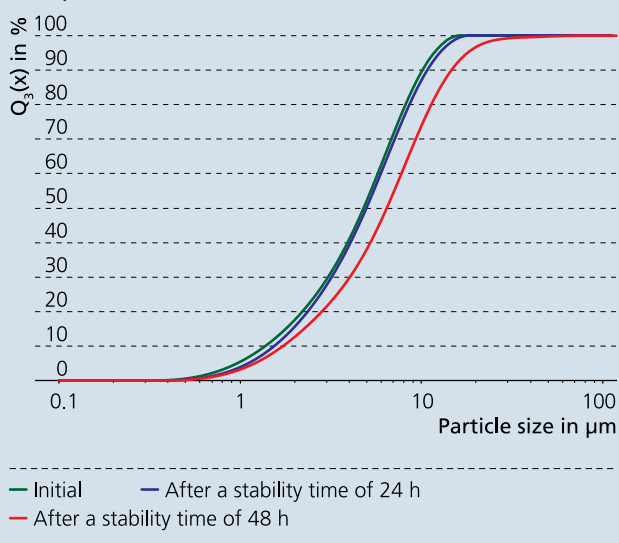

Services offered

- Particle characterization at accredited laboratory
- Particle size distribution; degree of agglomeration/ aggregation
- Specific surface area by BET, porosity
- Density
- Crystalline structure, chemical composition
- Surface charge/zeta potential

Toxicological assessment within the framework of the ParticleSafetyLab

- 1 *Ideal spheric substrate system.*
- 2 *Highly aggregated nano-scaled substrate system.*
- 3 *Initial nanoparticles next to sparingly soluble salt.*



WIRELESS ENERGY TRANSFER FOR ACTUATING AND SENSING TECHNOLOGY

Dr. Holger Lausch, Dipl.-Math. Michael Brand

Motivation

For the operation of energy consumers, which have to change their position or orientation in space and their distance from the primary source of energy without loss of performance in energy transfer, the well-known wireless energy transfer methods (WREL, WiTricity, gap induction, RFID, etc.) are only suitable under certain conditions. The system developed by Fraunhofer IKTS overcomes these limitations and is scalable in its performance parameters.

Operating principle

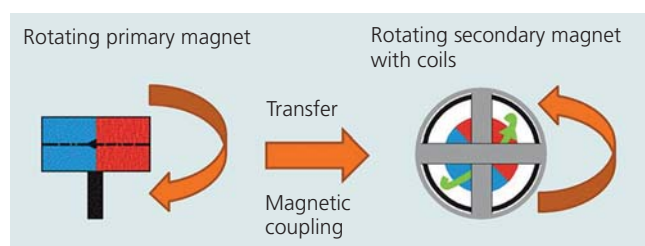

In the new method, a rotating magnetic field is generated through which motion energy is transferred to a movably supported magnetic body. This magnetic body is embedded in a generator unit near the electrical load and aligns independently of the position, orientation or distance of the rotating magnetic field. The system provides a tailored energy generation directly at the electric consumer's location with performances from a few milliwatts up to several watts and a range of up to 40 cm, for special applications even up to 1 m.

Advantages

- Scalable in performance and range
- Simple technical realization
- Energy efficient
- Can be mobilized and miniaturized
- Can be combined with ceramic bearing and housing components
- Biocompatible and no health risks
- Suitable for long-term use
- Option for determining the position and orientation of the generator module

Fields of application

- Energy supply in temporarily or permanently inaccessible areas
- Biocompatible energy transfer into the human organism (no heating of tissues and influence on neural and biochemical processes)
- Energy supply in areas of rotating components or explosion-prone environments
- Mobile diagnostic and therapeutic systems
- Sensor and actuator systems
- Electrochemical reactors
- Construction and building of monitoring systems
- Recovery of energy storage systems

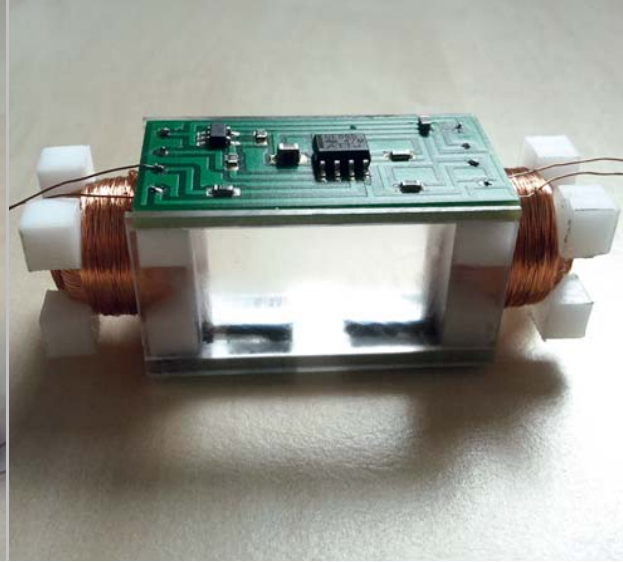
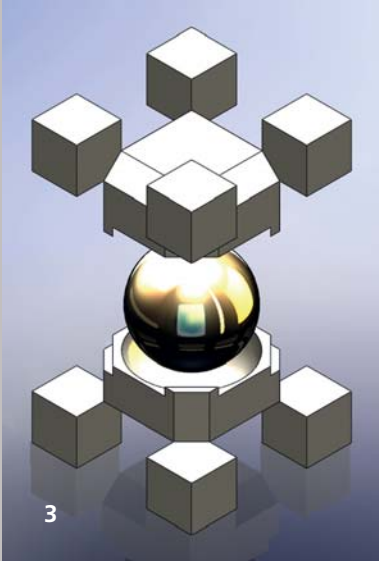

Performance parameters

The scalability of performance and range parameters mainly depends on the magnetic coupling, the rotation frequency of the magnetic rotating field and the loss of performance of the particular energy consumer. The efficiency can be scaled by a cascading system design, as several generator modules can be operated by a transfer module within the performance/consumption dependent range. The energy transfer system can be easily realized, mobilized and miniaturized. By using ceramic bearing and housing components with integrated electrical contacts as well as integrable rectification and conditioning components, OEM components can be designed and manufactured so that they are biocompatible and protected against physical and chemical influences.

Services offered

- Design and tailored adjustment of systems for wireless energy transfer
- Development of functionalized ceramic components for housing and easy system integration

Performance curves of a generator module for various frequencies

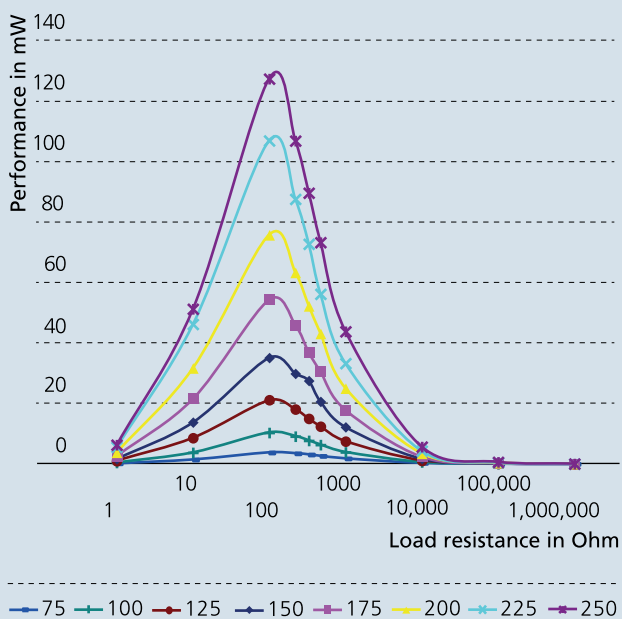

- 1 Wireless energy transfer of intelligent implants – demonstration system on the basis of a hip implant.
- 2 Mobile device at a belt for energy transfer into the human body.
- 3 Generator module with ceramic bearing/coil carrier and magnetic rotating body.
- 4 Generator module with 3D coils and conditioning electronics.

RESEARCH FIELD

ENERGY SYSTEMS

Department heads:

Dr. Mihails Kusnezoff

Dr. Christian Wunderlich

DEPARTMENT

MATERIALS AND COMPONENTS

Profile

The "Materials and Components" department is involved in the development and preparation of functional ceramic materials and their application in functional elements.

Traditional fields are thick-film technology, joining technology, high-temperature fuel cells (SOFC) and high-temperature electrolysis (SOEC), electrochemical storage devices as well as high-temperature chemical sensors. New competencies are being developed in the field of molten carbonate fuel cells (MCFC). Extensive experiences and outstanding technical equipment allow to control complex requirements and interactions in sophisticated applications such as fuel cells, Li-ion batteries and supercaps, sensors, microsystems, and packaging in complex materials systems. At the Dresden institute branch, screen printing pastes, inks, and slurries are developed to be used in electrochemical components and microsystems.

Materials development in combination with different coating methods – especially for applications in electrochemistry and joining technology – form the basis for the development of new components for SOFC/SOEC, MCFC, microbatteries, thermoelectric generators and sensors.

Close meshing with the "Chemical Engineering and Electrochemistry" and "System Integration and Technology Transfer" departments ensures the practical relevance of the results. This allows us to give our customers attractive

offers for materials, prototypes, and services along the entire process chain.

Services offered

- Development and preparation of pastes for screen printing, dispensing and roll coating as well as their pilot plant production
- Development and preparation of nanoinks for inkjet and aerosol jet printing
- Development and preparation of sealing glasses and elements as well as solders
- Glass development for specific applications
- Development of electrode materials and coatings for lithium ion batteries and supercaps
- Testing and inspection capacity for materials and functional high-temperature components for gas sensors, SOFC/SOEC and thermoelectric generators
- Development, manufacture, and testing of SOFC stacks
- Packaging for ceramic systems
- Consulting and materials analysis



Department head
Materials and Components

Dr. Mihails Kusnezoff
Phone +49 351 2553-7707
mihails.kusnezoff@ikts.fraunhofer.de



Joining Technology
Dr. Jochen Schilm
Phone +49 351 2553-7824
jochen.schilm@ikts.fraunhofer.de



**High-Temperature Electrochemistry
and Catalysis**
Dr. Nikolai Trofimenko
Phone +49 351 2553-7787
nikolai.trofimenko@ikts.fraunhofer.de



Ceramic Energy Converters
Dr. Stefan Megel
Phone +49 351 2553-7505
stefan.megel@ikts.fraunhofer.de



Materials MCFC
Dr. Mykola Vinnichenko
Phone +49 351 2553-7282
mykola.vinnichenko@ikts.fraunhofer.de



LONG-TERM STABLE ELECTRODES FOR SOFC/SOEC OPERATION

Dr. Nikolai Trofimenko, Dr. Mihails Kusnezoff

Today's energy systems can only cope with randomly occurring renewable energy sources (wind, sun) under certain circumstances, as power generation cannot be planned or predicted and the storage of any excess energy is only possible to a limited extent. High-temperature electrolysis can solve this problem by providing highest efficiency.

In electrolysis, the renewable energy is directly converted into hydrogen or synthesis gas, which can be processed into any fuel. The conversion into methane, in particular, provides promising synergies. So, it will be possible to couple electricity and natural gas grid. As a result, the flexibility of the energy systems can significantly be increased.

For years, Fraunhofer IKTS has been working on the development of electrodes for electrolyte supported cells (ESC) based on 10Sc1CeSZ electrolytes for the operation of solid oxide fuel cells (SOFC). Meanwhile, long-term redox and thermal cyclability of the new generation of electrodes based on a uLSMM'/10ScSZ cathode and a Ni/YSZ anode (G1) or Ni/GDC anode (G2 and G3) were realized in current projects by optimizing electrode composition and layer thickness. Using these cells in a SOFC stack, voltage degradation is < 0.6 %/1000 h.

In combined redox and thermal cycles (so called system cycles) as well, the stacks with the developed cells show a voltage degradation of < 2.5 % per 38 cycles. Thus, they are suited

Reproduction of ASR for G1, G2 and G3 electrolyte supported cells for SOFC operation

	Temperature in °C	ASR in Ωcm ²	ΔASR in Ωcm ²
G1 cell, 210 μm substrate thickness			
	861	0.192	± 0.003
	805	0.312	± 0.008
	752	0.542	± 0.011
	700	1.009	± 0.015
G2 cell, 210 μm substrate thickness			
	858	0.207	± 0.004
	805	0.352	± 0.008
	752	0.633	± 0.010
G3 cell, 210 μm substrate thickness			
	860	0.184	± 0.013
	804	0.321	± 0.022
	752	0.577	± 0.045

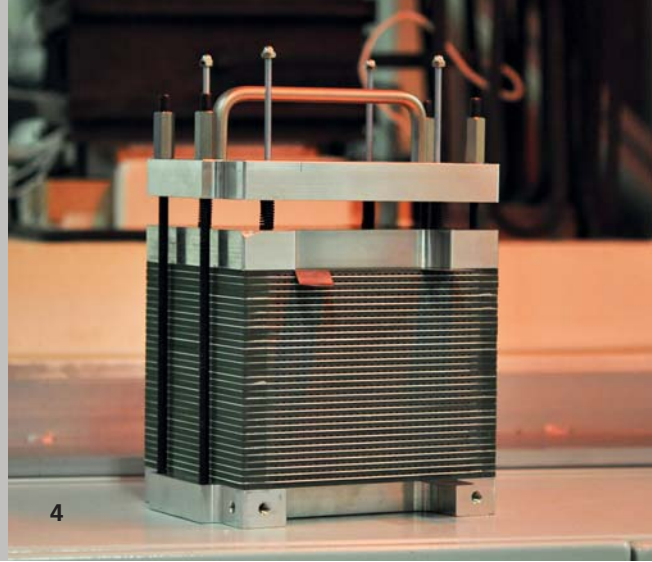
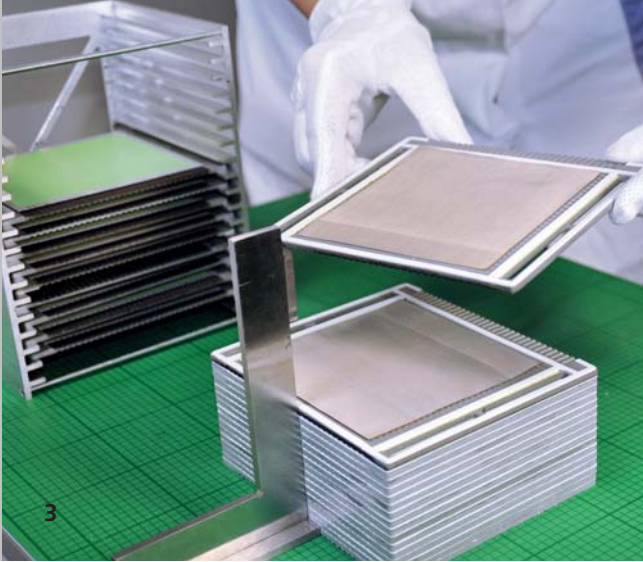

for SOFC systems where a high robustness is required. The developed cell types achieve an area specific resistance of 0.31 and 0.35 Ωcm^2 at 805°C. Power and degradation of the ESC cells manufactured at Fraunhofer IKTS with different anode compositions based on NiO/YSZ (G1) and NiO/CGO (G2) were determined in SOEC operation. In order to prove the long-term stability of the MEAs, the cells were tested for 3000 hours at 800°C using a hydrogen/water vapor mixture ($\text{H}_2:\text{H}_2\text{O} = 50:50$) at a current density of 300 mA/cm^2 . By optimizing the electrodes of the NiO/CGO cells for SOEC operation, this degradation rate was reduced to < 1 %/1000 h over 3000 h. The analysis of the impedance spectra showed an increase of the cell resistance, especially of the ohmic losses. This increase can be attributed to the change of the contact resistance between contact layer and cathode. Further durability enhancement requires a fine tuning of contact layer and ESC cathode.

Services offered

- Optimization and manufacturing of ESC for SOEC and SOFC operation
- Analysis of active materials or electrode pastes of commercial suppliers
- Electrochemical, microscopic and mechanical characterization of SOFC/SOEC cells
- ESC manufacturing in laboratory scale and up-scaling to pilot scale

Long-term operation of G2 cell in electrolysis mode

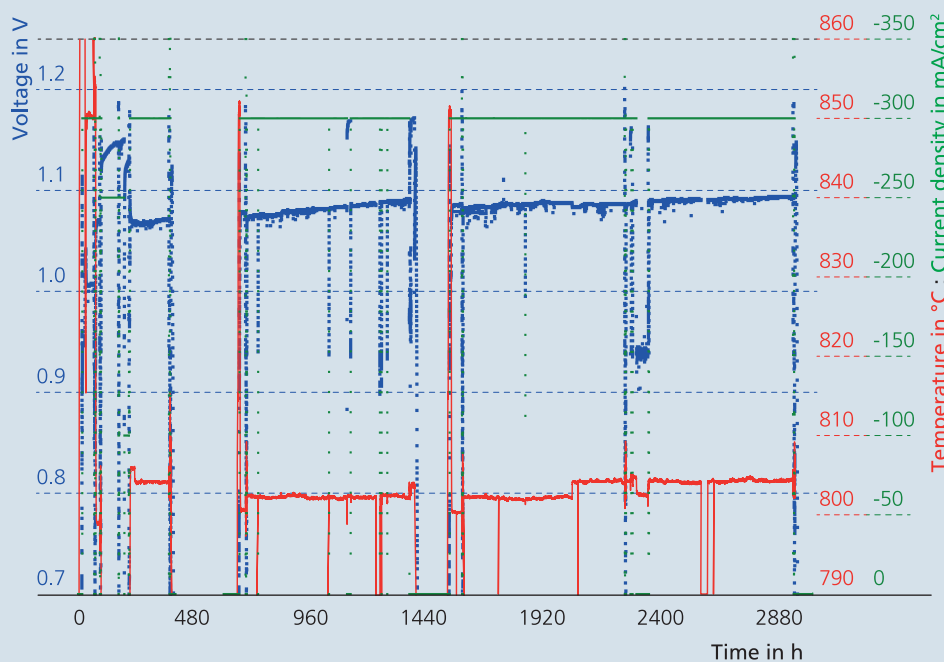

- 1 Paste preparation for screen printing on a three roll mill.
- 2 Screen printing of electrodes on electrolyte substrate.
- 3 Stacking of 30-cell stack.
- 4 Assembled/sealed 30-cell SOFC stack.

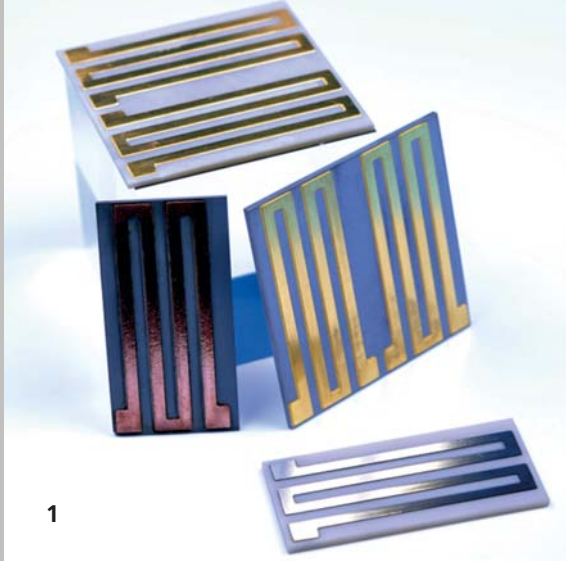

1

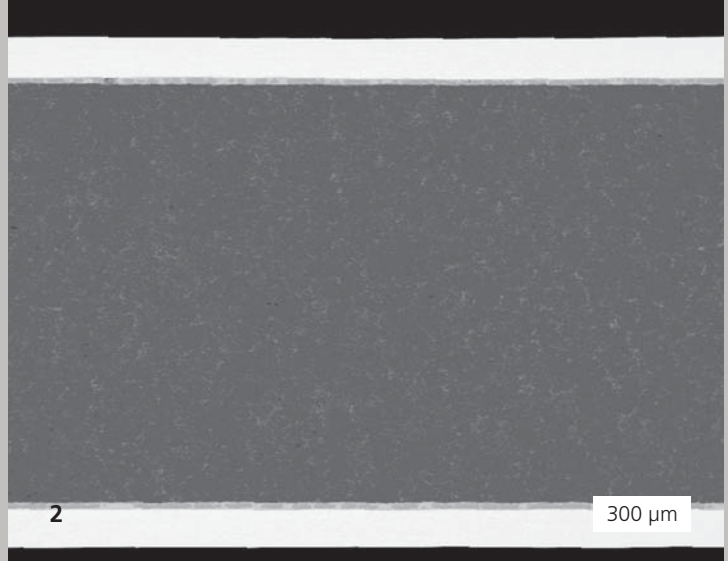

2

300 μm

METALLIZATION OF NITRIDE CERAMICS BY ACTIVE METAL BRAZING

Dipl.-Ing. Andreas Pönicke, Dr. Jochen Schilm

Ceramic substrates metallized with copper are widely used as circuit boards for power electronics (e.g. IGBT modules, switching power supplies, power inverter). However, appropriate substrates have to match a number of requirements. High heat losses caused by high current densities of mounted semiconductor components require composite materials with good heat conductivity or low thermal resistance as well as high stability against thermal cycles. These parameters mainly determine the lifetime of the circuit boards. Due to high CTE values and low thermal conductivities, oxide ceramics such as alumina (Al_2O_3) are limited in their suitability for these applications. Alternatives are the substrates made of aluminum nitride (AlN) or silicon nitride (Si_3N_4) ceramics. AlN is preferably used because of its excellent properties and high thermal conductivity. Due to a higher bending strength and better thermal shock resistance, Si_3N_4 represents a superior solution for applications with fast thermal cycles.

The bonding process of copper to ceramic substrates (such as Al_2O_3 and AlN) is mainly realized by a process called direct copper bonding (DCB) without any additional interlayers. Active metal brazing (AMB) of metallic foils to ceramic substrates in vacuum or in a protective atmosphere is used as an alternative bonding process (Figure 1 and 2). In case of DCB substrates the bonding phase is formed by a brittle ceramic phase. In comparison to DCB substrates, the joint strength is significantly higher and the active filler braze forms a ductile interlayer, what in turn results in a superior thermal shock resistance.

Process scheme for manufacturing of structured ceramic-metal composites by active metal brazing

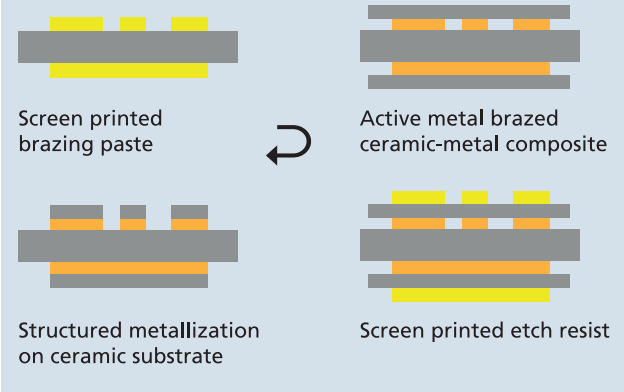

During the brazing process various failures can occur such as pore formation, delaminations or spreading of the molten braze, causing short circuits of the conducting paths on the substrate. Within research projects different analysis methods were applied in order to develop countermeasures for a considerably higher quality and reliability of metallized ceramic substrates. The reactivity of the active filler brazes and the joint materials were analyzed by DTA as well as defects in brazed components by scanning acoustic microscopy and SEM.

Based on these results, relevant parameters for the brazing process were varied systematically by using bench-scale furnaces:

- Furnace profiles (argon, vacuum)
- Surface treatment of copper foils
- Surface quality of ceramic substrates
- Content of the active element titanium in brazing pastes

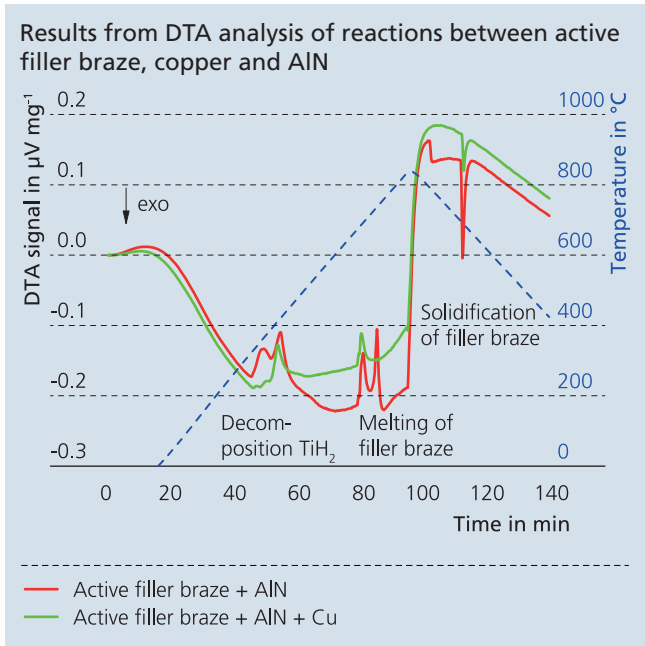
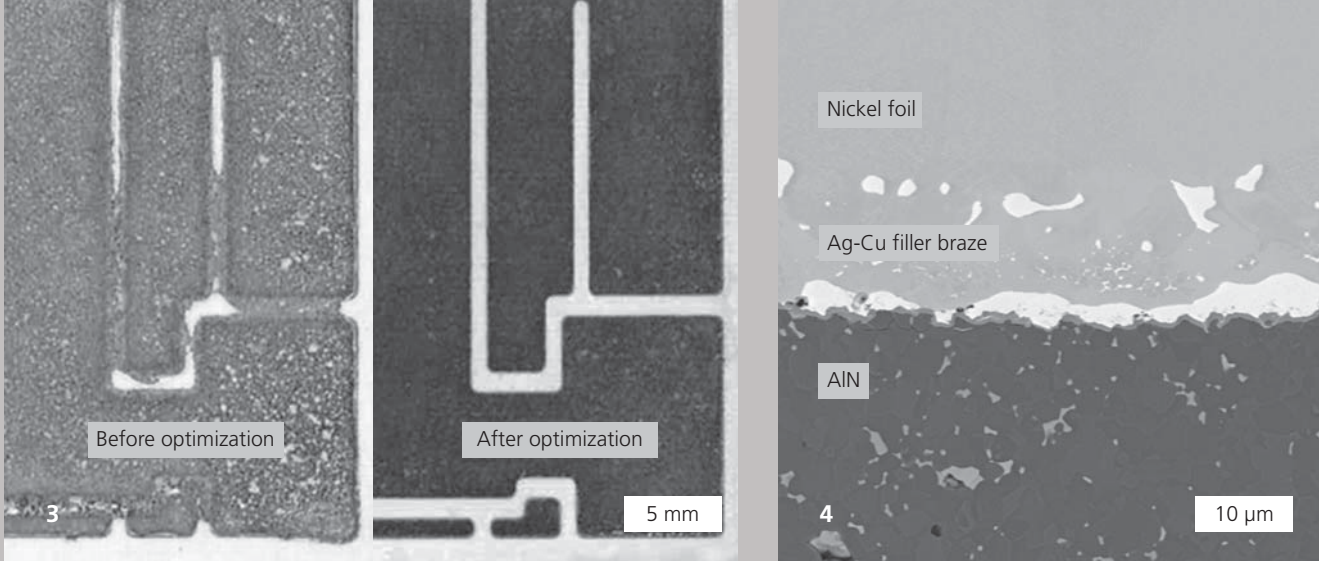

Services offered

- Development and characterization of ceramic-metal joints
- Optimization of brazing pastes and technologies
- Screen printing and dispensing technologies for the application of brazing pastes
- Furnace technologies for induction brazing and brazing processes in protective atmospheres and vacuum (up to 2400°C, up to 10^{-5} mbar, max. 20 dm³)
- Non-destructive and destructive testing and characterization of brazed joints
- Investigation of long-term stability in oxidizing atmospheres and in aggressive media (gaseous and liquid) at high temperatures

As a result of these investigations, the reliability of the brazing process was improved and a significant increase of yield in manufacturing of copper-ALN and copper-Si₃N₄ joints in industry was achieved (Figure 3).

Additionally, active metal brazing (AMB) offers the possibility to realize other metallizations on nitride ceramics, what makes this process attractive for new applications. Thermoelectric modules, for example, require oxidation resistant metallized ceramic substrates with high thermal shock resistance and high ampacity of the conducting paths. The limited stability of copper at temperatures above 150°C suggests the application of the more stable metallization layers such as nickel or refractory metals for the ceramic substrates (Figure 4).

- 1 Metallized nitride ceramics with etched conducting paths.
- 2 Cross-section of a defect-free active metal brazed ALN-metal joint.
- 3 Microscopic image of spread braze between conducting paths on Si₃N₄.
- 4 SEM image of a brazed seam in between a nickel-ALN joint.

RESEARCH FIELD

ENERGY SYSTEMS

Department heads:

Dr. Mihails Kusnezoff

Dr. Christian Wunderlich

DEPARTMENT

SYSTEM INTEGRATION AND TECHNOLOGY TRANSFER

Profile

The "System Integration and Technology Transfer" department – an interface between application and customer – pools the expertise of Fraunhofer IKTS in the field of materials and technology development. Its aim is the development of complete energy systems. Currently, research activities are focused on fuel cell generators and battery storage systems as well as other energy storage systems.

This focus enables the department to realize the development of specific systems based both on market and customer requirements and on available technological options. Based on a comprehensive validation and gap analysis of technology maturity, both the feedback into materials and components development and the quick solution of identified technical aspects are guaranteed. By setting the priorities on important technological aspects in the development of materials and components, Fraunhofer IKTS significantly contributes to the market launch of new energy conversion technologies as well as to their conversion and resource efficiency.

In order to develop large series production processes and quality assurance methods, a small series production of prototypes can first be carried out in the laboratories and pilot plants of Fraunhofer IKTS or in cooperation with our customers. This holistic approach allows industrial cus-

tomers a resource-saving and risk-reduced development of highly innovative products and technologies.

Thus, Fraunhofer IKTS is qualified as a contractor for the complete process of technology development and the stepwise knowledge transfer into series production at the customer's site.

Services offered

- System concepts, including simulation-assisted synthesis and dynamic simulation of complex energy conversion and storage systems
- Multi-criteria optimization of system structures according to the Pareto principle based on the customer's functional goals
- Prototype assembly, functional tests and validation of performance and lifetime parameters of energy systems in specially equipped laboratories within the performance range provide energy generation of some mW and 10 kW (focus: fuel cell and battery systems as well as hybrid systems of fuel cells and batteries)
- Postmortem analysis to study aging processes or failure mechanisms of Li-ion batteries and solid oxide fuel cells
- Construction and operation of test stands for the study of specific aspects, e.g. in the high-temperature range
- Realization of prototype production and quality assurance processes on a laboratory, pilot plant and industrial scale



Department head

System Integration and Technology Transfer

Dr. Christian Wunderlich

Phone +49 351 2553-7232

christian.wunderlich@ikts.fraunhofer.de



System Concepts

Dipl.-Ing. Thomas Pfeifer

Phone +49 351 2553-7822

thomas.pfeifer@ikts.fraunhofer.de



Validation

Dipl.-Ing. (FH) Jens Baade

Phone +49 351 2553-7338

jens.baade@ikts.fraunhofer.de



Energy Storage Systems

Dr. Mareike Wolter

Phone +49 351 2553-7971

mareike.wolter@ikts.fraunhofer.de



EFFICIENT COMBINED HEAT AND POWER APPLICATIONS IN THE MW POWER CLASS

Dr. Christian Wunderlich, Dipl.-Ing. Andreas Frömmel (FCES GmbH)

Since June 2012, Fraunhofer IKTS has been holding 25 % of the shares in the joint venture Fuel Cell Energy Solutions GmbH (FCES) with its registered office in Dresden. The US Fuel Cell Energy, Inc. (NASDAQ: FCEL), a leading manufacturer of ultra-clean, efficient and reliable power plants, is partner in this joint venture. The product portfolio of FCES GmbH comprises Direct FuelCell (DFC®) power plants ranging in output from 250 kW to 2.8 MW. The power plants can be combined to large fuel cell parks.

FCES uses the MCFC technology (molten carbonate fuel cell) for its fuel cells. Using this technology, extremely large fuel cell stacks can be realized. So, the technology cuts out for the efficient baseload power in the MW class. The brand Direct Fuel Cell DFC® points to the direct reformation of hydrocarbons in the fuel cell stack, what is indispensable to realize the thermal management of the large stack.

MCFC fuel cell systems provide ultra-clean electricity and heat in a highly efficient and reliable manner, as power generation is virtually absent of pollutants such as NOx and SOx. The plant efficiency is currently about 47 %. These fuel cells can achieve up to 90 % efficiency when configured to use the high-quality heat generated by the power plant in a com-

combined heat and power (CHP) mode. High efficiency reduces fuel cost and carbon emissions, and producing both electricity and heat from the same unit of fuel drives economics while simultaneously promoting sustainability. Due to their temperature level and technology, MCFC power plants are suited to be powered by both natural gas and biogas. Waste heat at a temperature level of 400°C cannot only be used as process steam but also in absorption and adsorption refrigeration units.

Cooperating with Fraunhofer IKTS, FCES GmbH plans to develop and test new application fields for this technology such as e.g. plants with parallel hydrogen generation. A short-term and even more important research focus is to enhance the lifetime of the stack module from 5 to 7 years, in the long-term to 10 years. This is crucial for an economical plant operation over a period of 20 years, because the planned stack replacement is included in the full service cost. In case of success, power generation cost below the grid level can be achieved. Fraunhofer IKTS will continue its applied research in the field of MCFC core technology using its competencies in the conditioning of powders, preparation of slurries, characterization of fuel cells and stacks as well as related simulation expertise.

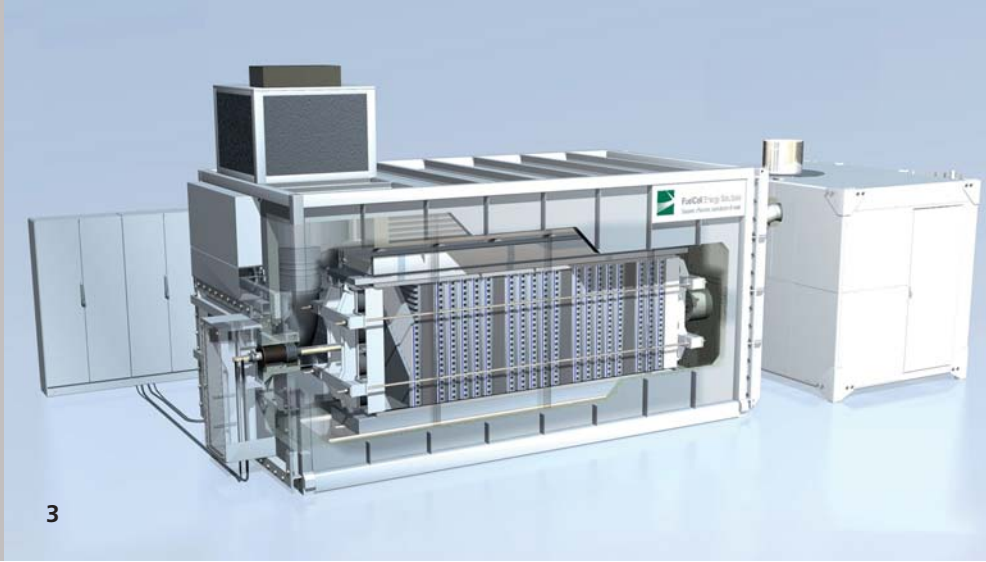

DFC plants provide continuous baseload power and can be sited where the power is used including both on-site applications and electric grid support. The combination of near-zero pollutants, modest land-use needs and quiet operation of DFC plants facilitates their siting in urban locations.

Thus, reliable fuel cell power plants in the MW power class are available in Europe for the first time. Already in the short-term, DFC® systems can significantly contribute to reorganize power supply and to realize an infrastructure that is primarily powered by renewable energies.

The sales territory of the German FCES GmbH comprises Europe with the adjacent regions in the Middle East, North Africa and Russia.

Worldwide more than 80 DFC plants are operated. Over 300 MW of power generation capacity are installed or in backlog.

The cooperation with FCES GmbH and Fuel Cell Energy, Inc. means for Fraunhofer IKTS an additional push in the development of solid oxide fuel cells. Knowledge in the field of system components for large fuel cells and the assembly of large stack modules can partly be transferred to IKTS SOFC technology. The leading role of the institute in this field in Europe is strengthened once more.

- 1 Aerial photograph: 2.8 MW DFC plant in Incheon, Korea (source FCE Inc.).
- 2 1.4 MW plant using biogas in South Bay, California (source FCE Inc.).
- 3 Cross section: 400 kW plant (source FCES GmbH).
- 4 350 kW fuel cell stack and MCFC single cell.



ENERAMIC® – STATE OF DEVELOPMENT AND PROTOTYPE TESTING OF SOFC SYSTEM

Dipl.-Ing. (FH) Sebastian Reuber, Dipl.-Ing. (FH) Jens Baade, Dr. Christian Wunderlich

The current aim of the eneramic® project is to develop prototypes of a mobile fuel cell system for off-grid power supply which are ready for field tests. The system is designed as battery hybrid, and thus is an economic and long-life alternative to existing technologies for applications in the field of traffic, security and telecom technology or for outdoor activities.

eneramic® systems are specially designed for these markets and are powered by propane gas or LPG, a cheap and worldwide available fuel of high energy density. At rated operation the system provides a net power of 100 W at 12 V. It is the aim to achieve a lifetime of at least 5000 operating hours at 300 start/stop cycles.

Development concept

A planar solid oxide fuel cell (SOFC) is the core component in the eneramic® system. The cell stack was specially designed for portable applications and is characterized by a simple and compact design. Almost 20 years of technology experience of Fraunhofer IKTS have gone into the stack and its components. All system components for gas conditioning, thermal management and the electrical converter system were developed at Fraunhofer IKTS within the framework of a Fraunhofer internal foundation project. Meanwhile, they are designed, built and tested on pilot scale. eneramic® core components can be reproducibly manufactured with a deviation of +/- 1.4 % of their gross power.

From operational experiences, a specific control system has been derived and validated in laboratory tests putting the system into rated operation after a short heating period. The entire development is protected by a comprehensive patent cluster for components and system.

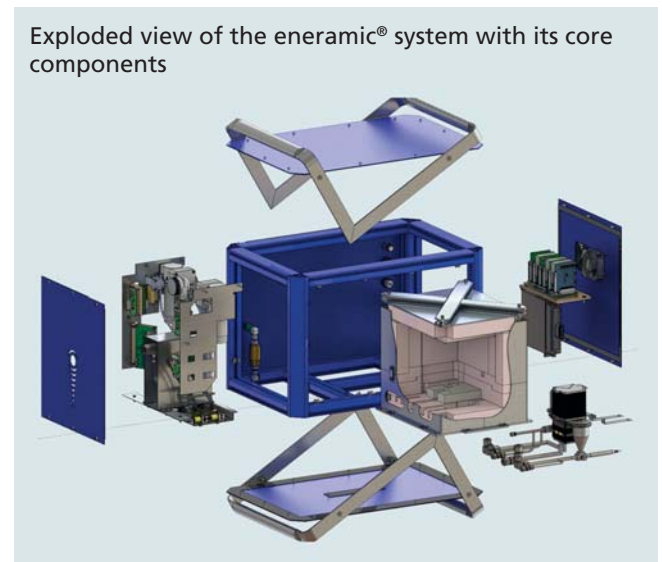

Certification process

The security concept is worked out based on the IEC62282-3-1 standard. As the certification partner TÜV Süd accompanies the project it is ensured that the security concept meets the requirements for industrialization.



At the beginning, any risks were systematically documented in a system FMEA and the necessary measures were derived. Despite the early development stage these measures were implemented in the control system of the prototypes.

Results of prototype tests

At the moment, tests are performed at component, assembly and prototype level. First results of the automated start/stop cycles under real operating conditions show a stability of 0.3 % power loss per cycle.

Meanwhile, life times of up to 3000 hours have been achieved for the core assembly in continuous operation, and degradation has been reduced to less than 1 % per 1000 hours for the latest generation. Since May 2012, self-sufficient prototypes have been running in automated continuous operation under laboratory conditions. As the entire value chain of this development is covered by Fraunhofer IKTS, the findings gained in the system tests are directly transferred to the development of the next stack and system generation but also to similar research projects.

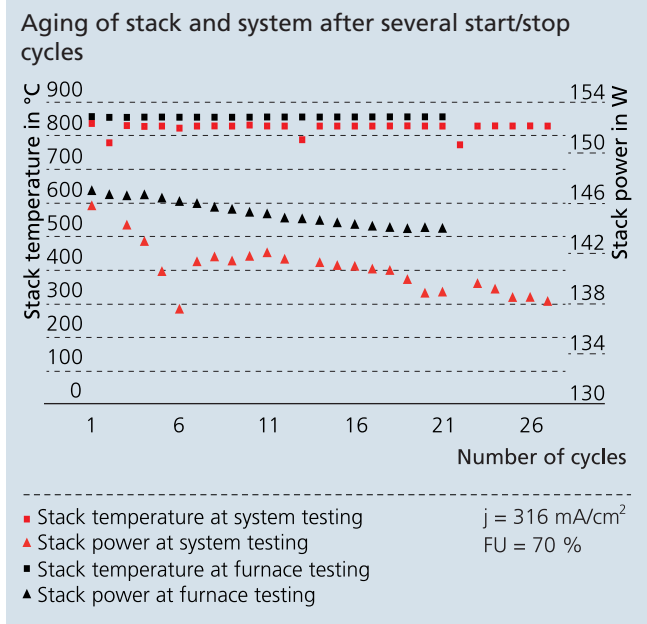

A product development and series production of application-specific modifications of the eneramic® system is pursued. Fraunhofer IKTS additionally offers services in the development and manufacturing of fuel cell systems of various power classes.

Self-sufficient prototype in automated continuous operation (100 hours)

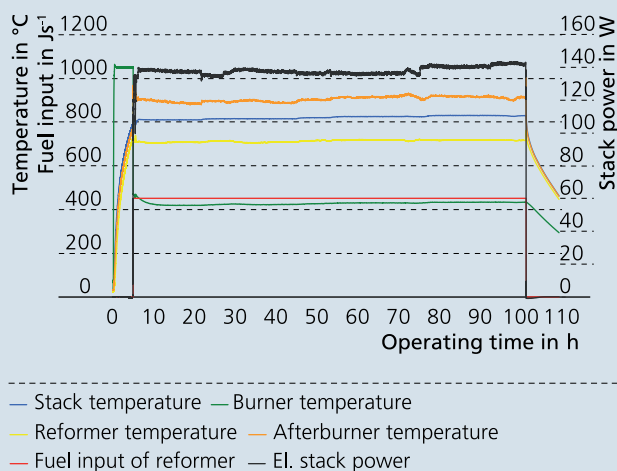

- 1 Application field traffic engineering.
- 2 System prototype with 3 kg gas bottle.
- 3 Prototype assembly.
- 4 Automated multiplex laboratory test.

RESEARCH FIELD

SMART MICROSYSTEMS

Department heads:

Dr. Andreas Schönecker

Dr. Uwe Partsch

DEPARTMENT

SMART MATERIALS AND SYSTEMS

Profile

The "Smart Materials and Systems" department is specialized in developing dielectric functional ceramics and integrating them into devices, microsystems and active structures. Research covers all aspects of the value chain, ranging from materials synthesis to functional verification in prototype systems.

Functional optimization is accordingly performed on several scales, through utilization of property combinations of composites, functional consolidation in materials, and adaptation of components to the system environment.

Special materials expertise exists in the field of complex perovskites, which, as high-performance piezoceramic or dielectric ceramics, provide sensing, actuating, and electronic functions in monolithic components and composites with polymers, metals, glasses, and other ceramics. Thick-film, multilayer, and piezocomposite technologies are available as closed technology chains. Within the framework of the Attract project "Material mechanics of functional ceramics", these competencies are completed by studying and adjusting the electromechanical coupling in smart materials and their systems.

Preparation of thin-film structures is done by CVD, PVD, and sol-gel processes in combination with reactive ion etching for structuring. With this technology portfolio we

offer new materials solutions for semiconductor technology and wear protection.

With regard to system applications, unique design and characterization tools are being developed and used. These tools describe the interaction of piezoelectric transducers with both electronic circuits and mechanical and acoustic subsystems and lead to innovative developments in piezotechnology, adaptronics/mechatronics and ultrasound technology.

Services offered

- Development, production and characterization of dielectric ceramics
- Technology development based on powders, fibers and coatings
- Development of components for specific applications in sensor, actuator, and ultrasound technology as well as electronics, wear protection and light-weight construction with integrated functions
- Modeling and simulation on the material, component and system level
- Characterization of dielectric, piezoelectric, and ferroelectric functional properties
- Vibration and sound field measurements
- Scientific instrument design, electronics, and software development



Department head
Smart Materials and Systems

Multifunctional Materials and Components

Dr. Andreas Schönecker
Phone +49 351 2553-7508
andreas.schoenecker@ikts.fraunhofer.de



Functional Layers for Microelectronics and Wear Protection

Dr. Ingolf Endler
Phone +49 351 2553-7693
ingolf.endler@ikts.fraunhofer.de



Applied Material Mechanics

Dr. Peter Neumeister
Phone +49 351 2553-7372
peter.neumeister@ikts.fraunhofer.de



OXIDE TARGETS FOR INTEGRATED THIN FILMS

Dr. Andreas Schönecker, Dr. Sylvia Gebhardt

The „Multifunctional Materials and Components“ working group of Fraunhofer IKTS is dealing with the synthesis of various functional ceramics, which are well suited for information and energy storage, energy conversion as well as for integrated optical, acoustical and electronic devices in microsystems. The availability of oxide targets is an essential prerequisite in processing of microsystems if functional thin films are prepared by sputtering (PVD) or pulsed laser deposition (PLD). The targets have to be adjusted to the type of equipment and the process windows used.

General quality requirements for ceramic targets are high density (> 96 % theoretical density), adjusted target composition to obtain the specified chemical composition of the growing film, chemical homogeneity as well as uniform microstructure. Targets are required in different sizes, typically in cylindrical form with diameters ranging between 25 mm (1 inch) during the development time period up to 150 mm (6 inch) and larger in the production period. The thickness is usually limited to 12 mm (0.5 inch). The work described here aimed at the development of fabrication technologies of targets made of

ferroelectric complex oxides. In particular, we were studying the correlations between powder syntheses, press granulate fabrication, press parameters and target quality. As example, ferroelectric complex perovskites of lead titanate zirconate (PZT), lead manganese niobate-lead titanate (PMN-PT) and barium titanate (BT) were chosen.

Results

Starting point of processing are oxides of defined purity with the specified mixing ratio. The powders are mixed in a suspension, followed by drying, calcining and processing to a ready-to-press granulate.

For granulate preparation, suitable binder and lubricants were identified. The calcined powders were coated with additives in the suspension and then spray dried to give free-flowing granules. Suited spray dryer equipment is available at Fraunhofer IKTS.

Overview on prepared and available oxide targets

Material	Composition	Dimensions (green)	Dimensions (sintered)
BT	BaTiO ₃	lxb = 124 x 124 mm ²	lxb = 100 x 100 mm ²
PZT	Pb _{1,025} Zr _{0,2} Ti _{0,8} O _{3,025}	d = 160 mm	d = 134 mm
	Pb _{1,025} Zr _{0,3} Ti _{0,7} O _{3,025}	d = 160 mm	d = 136 mm
	Pb _{1,025} Zr _{0,52} Ti _{0,48} O _{3,025}	d = 160 mm	d = 138 mm
PMN-PT	0,67 Pb ₃ MgNb ₂ O ₉ -0,33 PbTiO ₃	d = 30 mm	d = 25 mm
		d = 160 mm	d = 130 mm



Ceramic green bodies were prepared by uniaxial pressing. Different press types were tested using pressing matrixes of the following sizes $d = 30 \text{ mm}$, $d = 160 \text{ mm}$, $l \times b = 124 \text{ mm} \times 124 \text{ mm}$. After that, sintering under controlled atmosphere was performed with optimum arrangement of the sintering units in the sintering furnace and regulated temperature-time profile. The formulation of the starting powder mixture took into consideration the target value of the final composition of the film and specific requirements of the perovskite synthesis. Concerning the PZT materials, the Zr/Ti ratio spanned systematically over the range $Ti = 0.48\text{--}0.8$. Defect free targets were obtained with the exception of the Ti-rich composition $Ti = 0.8$.

The PMN-PT solid solution was prepared employing the columbite route in order to avoid pyrochlore as secondary phase in the ceramic target.

Concerning barium titanate, particular attention was given to control the dielectric data, like temperature behavior of permittivity and Curie temperature, very exactly, which was attained by highly defined chemical purity and homogenous microstructure.

Finally, the sintered ceramic body was finished by mechanical treatment with cutting and grinding to meet low tolerances of $< 100 \mu\text{m}$.

The preparation technology of targets is controlled by qualified measurement and characterization methods ensuring reproducible product quality. Powder and suspension characterization uses particle size and surface area measurements (BET). Phase content, chemical purity, density and microstructure of obtained ceramic wafers were analyzed on demand.

Services offered

- Technology development for oxide ceramic targets
- Flexible adjustments of processing and products to suit custom needs
- Preparation and supply of specified prototypes

1 PMN PT targets, diameter = 25 mm.

2 BaTiO_3 target, length x width = 100 mm x 100 mm.

3 PZT starting powder.

4 Powder preparation in a planetary ball mill.

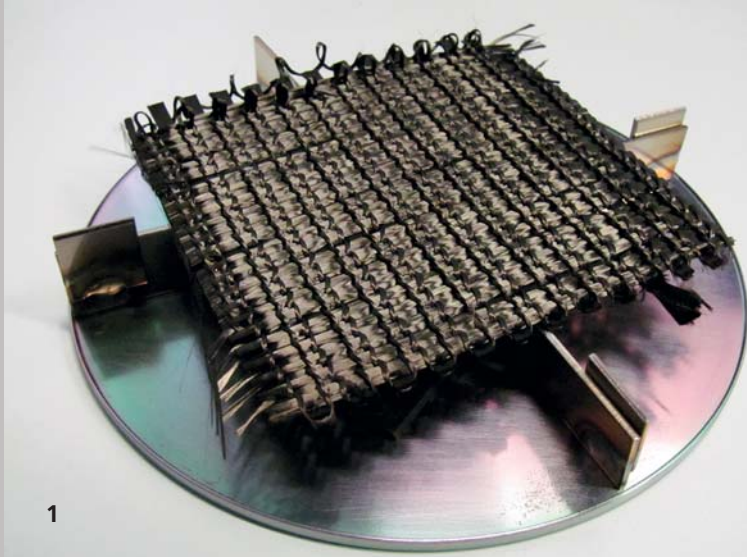

COATING OF 3D CARBON FIBER TEXTILES BY CVD AND ALD

Dr. Mandy Höhn, Dipl.-Phys. Mario Krug, M.Sc. Alfaferi Zainal Abidin

Introduction

In lightweight applications fiber-reinforced materials are often used to meet the complex application requirements. These materials must have a low weight on the one hand, and withstand high mechanical loads on the other hand. During liquid phase infiltration of 3D carbon textile preforms, the fibers are exposed to an aggressive metal melt at high temperatures. Particularly at the interface between carbon fiber and metal melt reactions can occur leading to carbide formation. Moreover, these reactions may cause a complete dissolution of the fibers in the metal matrix. To avoid or to minimize this undesired effect the fibers are covered with an additional protective layer.

Results

At Fraunhofer IKTS, different deposition technologies for the manufacturing of protective layers on carbon fiber textiles are available. Using chemical vapor deposition (CVD) and atomic layer deposition (ALD), homogeneous layers can be deposited on textile fiber preforms. In the ALD process, the precursors are sequentially led into the process chamber and separated by purge pulses. This process allows to deposit oxide layers like alumina (Al_2O_3) at a low substrate temperature (220°C) using the precursors trimethylaluminum (TMA) and ozone or gaseous water. The layer thickness is adjusted by the number of precursor pulse cycles. The low thermal load enables a preservation of the tensile strength of the fibers.

An Al_2O_3 layer that is only 20 nm thick even improves the oxidation resistance of the carbon fiber textile significantly. This can be shown by a thermogravimetric analysis (TGA) which is illustrated in the diagram below. The oxidation resistance can be further improved by increasing the Al_2O_3 layer thickness to 40 nm. According to XRD measurements, deposited layers are amorphous and start to crystallize above 800°C .

TiN prepared by CVD is another type of protective coating. The CVD process for TiN deposition uses a precursor mixture

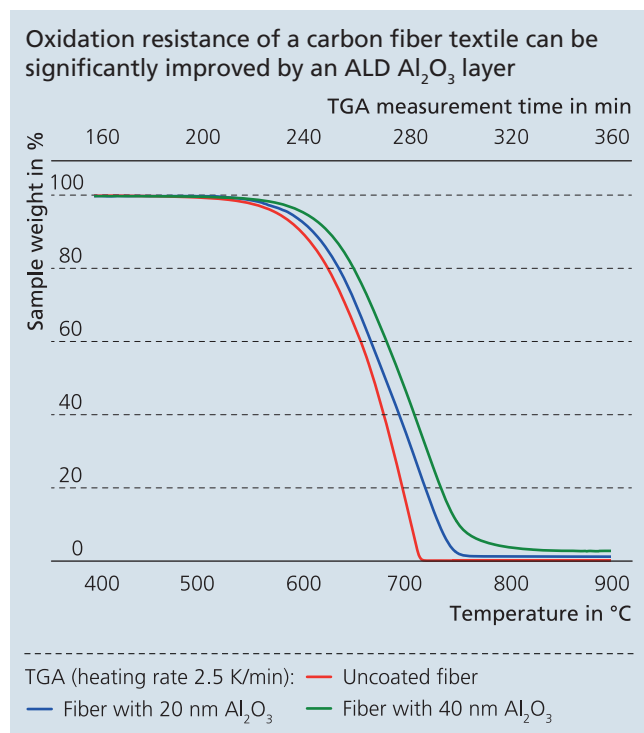

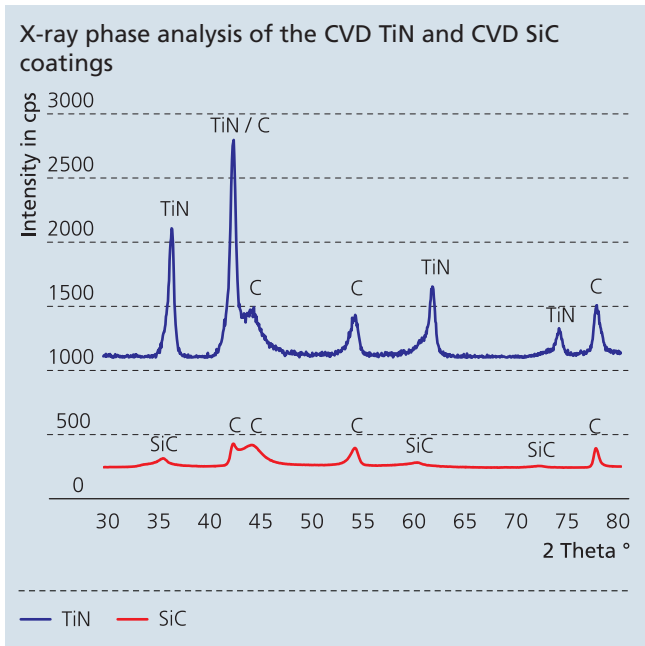
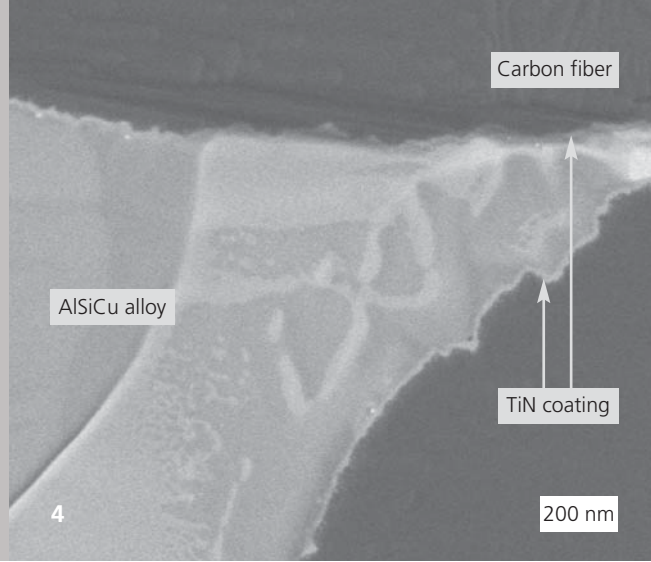
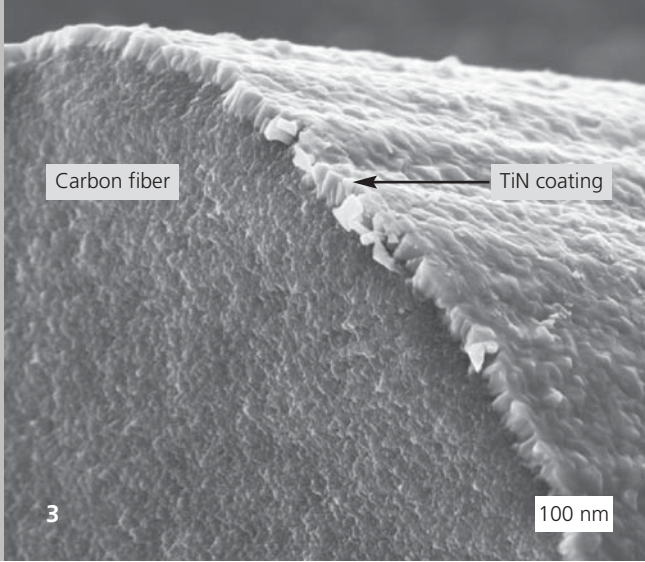

The CVD process can also be used to produce protective layers of SiC. The deposition is carried out with a gas mixture of SiCl_4 or Si_2Cl_6 , C_2H_4 and H_2 . It is necessary to optimize deposition temperature and pressure to obtain a homogenous layer thickness inside the carbon fiber textile. A reduction of the deposition temperature increases the layer homogeneity and leads to nanocrystalline and partly amorphous SiC layers (see XRD analysis in the figure left). The deposition of these layers as gradient layers and multilayer coatings is possible as well.

Acknowledgments

The presented results were obtained in a joint research project between Germany and Poland which was financially supported by the DFG (DFG EN 302/2-1).

Services offered

- Development of CVD and ALD processes
- Deposition of prototype layers for product development
- Complex characterization of deposited layers

of TiCl_4 , N_2 and H_2 . Adjusting the gas flow as well as the process pressure at a deposition temperature of 850°C , a homogeneous layer thickness distribution within the fiber preform is obtained. The applied TiN layer thickness is varied between 20 nm and 100 nm. A fractograph of a carbon fiber with a 100 nm TiN layer is shown in Figure 3. As presented in the XRD analysis above, the deposited TiN layers are crystalline, having a crystallite size of 80 nm to 100 nm.

The TiN layer results in a reduction of tensile strength of the carbon fibers. A carbon fiber with a thin TiN layer of 25 ± 10 nm has a mean tensile strength of about 2.2 GPa as compared to 3.9 GPa for an uncoated carbon fiber. TiN coated carbon fiber textiles were successfully infiltrated with an AlSiCu alloy. The TiN layer shows an excellent wettability with this alloy.

As shown in Figure 4, the TiN layer is preserved on the carbon fiber as protective coating even after infiltration. The carbon fibers are completely covered without any visible defects.

- 1 Fiber preform coated with an ALD Al_2O_3 layer.
- 2 ALD 100 lab coater.
- 3 Fractograph of a TiN coated fiber.
- 4 TiN coated carbon fiber preform infiltrated in an Al alloy.

RESEARCH FIELD

SMART MICROSYSTEMS

Department heads:

Dr. Andreas Schönecker

Dr. Uwe Partsch

DEPARTMENT

HYBRID MICROSYSTEMS

Profil

The department "Hybrid Microsystems" is focused on the development of functional ceramic materials, miniaturized components and systems. Fields of applications are electronic packaging, high-power electronics, sensors, and energy technology (e.g. micro-fuel cells, battery technology and photovoltaics).

In addition to the development of customized pastes and inks for classic applications in hybrid electronics (e.g. conductor, resistor and encapsulating pastes for AlN), our customers benefit from an extensive know-how in the development and adaptation of magnetic materials as well as non-linear dielectrics and resistors (PTC, NTC). Furthermore, we are experts in the development and preparation of our own application-specific glasses which are used as essential composites in pastes, inks and tapes.

For the deposition of functional layers, both classic screen printing technology and additional mask-based (stencil and gravure printing) and digital printing processes (aerosol and inkjet printing) can be used, depending on the application requirements. The minimum lateral resolution of these printing methods is $< 10 \mu\text{m}$.

One main focus of our research activities is on the "Tape Casting Competence Center". At the Hermsdorf institute branch, we are able to develop and prepare customized ceramic tapes on a pilot scale. According to the requirements on tapes and

properties of the applied slurries, different tape casting methods are used (e.g. doctor blade, comma bar and slot die).

To further process these tapes into 3D-structured components, a complete ceramic multilayer technology line (LTCCs, HTCCs) is available at Fraunhofer IKTS. In cooperation with industry partners, we also run two pilot plants in which developed materials and processes are tested and optimized with consumers in a semi-industrial environment (PV pilot plant with Roth & Rau AG, battery pilot plant with ThyssenKrupp System Engineering GmbH).

In the field of electronic packaging, we offer our customers a wide range of technologies for electrical contacting (soldering, gluing, bonding) and for mechanical and microstructural characterization of electrical connections.

Services offered

- Development, preparation, and characterization of application-specific functional ceramic materials (inks, pastes and tapes)
- Component design, development, and characterization
- Electrical systems integration of ceramic components
- Development and optimization of technologies and assessment of scalability



Department head
Hybrid Microsystems

Dr. Uwe Partsch
Phone +49 351 2553-7696
uwe.partsch@ikts.fraunhofer.de



Thick-Film Technology and Photovoltaics

Dr. Markus Eberstein
Phone +49 351 2553-7518
markus.eberstein@ikts.fraunhofer.de



Microsystems, LTCC and HTCC

Dr. Steffen Ziesche
Phone +49 351 2553-7875
steffen.ziesche@ikts.fraunhofer.de



Functional Materials for Hybrid Microsystems

Dr. Stefan Barth
Phone +49 36601 9301-1868
stefan.barth@ikts.fraunhofer.de



Systems Integration and Electronic Packaging

Dr. Lars Rebenklau
Phone +49 351 2553-7986
lars.rebenklau@ikts.fraunhofer.de

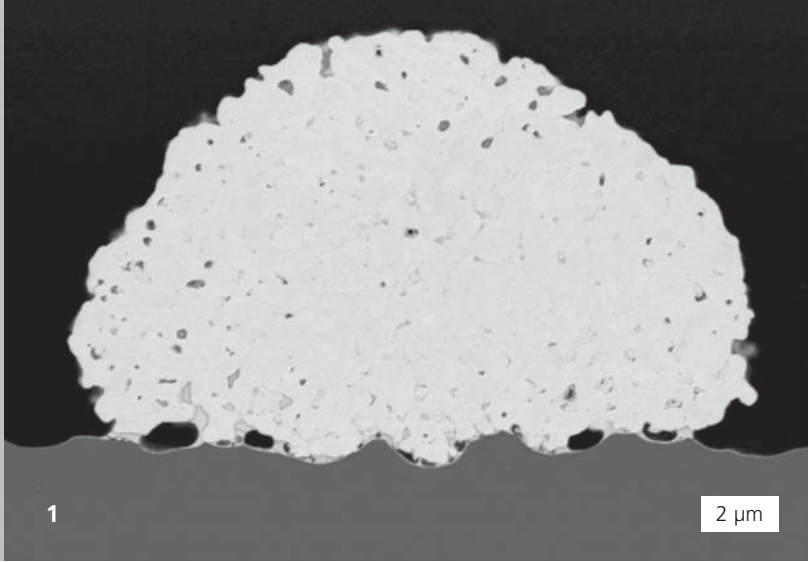

LEAD-FREE PV PASTES WITH OPTIMIZED RHEOLOGY AND CONTACT FORMATION

Dr. Markus Eberstein, Dipl.-Ing. Stefan Hainich, Dipl.-Ing. Kathrin Reinhardt

Silver electrodes for front side metallization of silicon solar cells are mainly manufactured by screen printing and subsequent firing as it is a cost-effective manufacturing method. The efficiency of solar cells can be enhanced by (i) enlarging the free cell surface area and (ii) reducing the contact resistance between the silicon cell and the silver busbar. A large free cell surface can be achieved with an adjusted paste

justed relaxation behavior after the paste has been deposited. Thus, narrow silver fingers with high aspect ratios are obtained (Figure 1). Another fact is that the rheological properties influence the dispersion of the solids in the paste volume. Thereby, homogenous surface wetting and allocation of the silver ($\geq 90\%$) and glass ($\leq 10\%$) powders are achieved. This is an essential requirement for the formation of consistent high-efficient contacts in the subsequent rapid firing process.

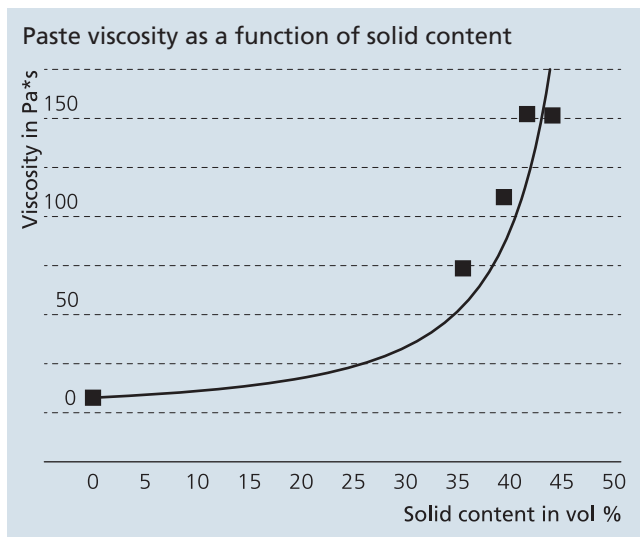

rheology enabling the printing of narrow, but high silver fingers. Such pastes have a very high solid content and tend to change their viscosity by several orders of magnitude when the solid content slightly varies (diagram above). Variations in the concentration and average molecular mass of ethyl cellulose as well as in the solid content were investigated to adjust the rheological characteristics of the silver paste (diagram on the right). The resulting paste shows shear thinning under high shear stress during the screen printing process and ad-

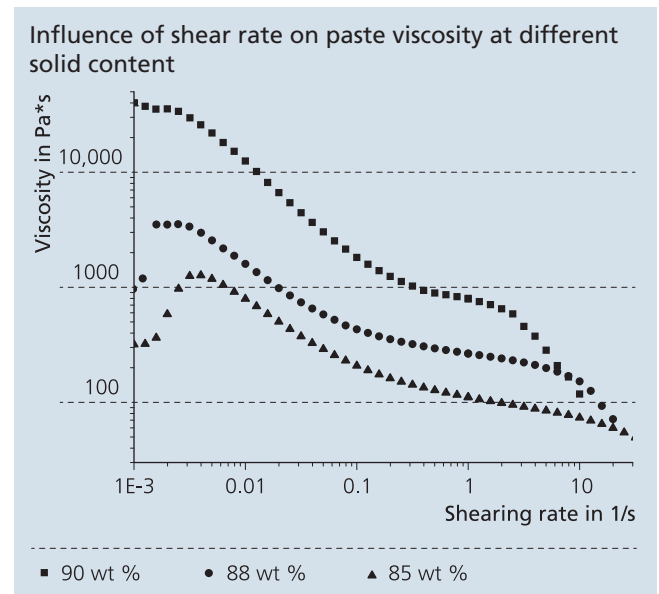

The thermal contact formation of glass-containing silver pastes is a very complex process. The silver is dissolved under oxidation in the glass, transported by diffusion and deposited at the silicon surface. These processes take only some seconds. Thus, the solution and redox processes are not in thermodynamic

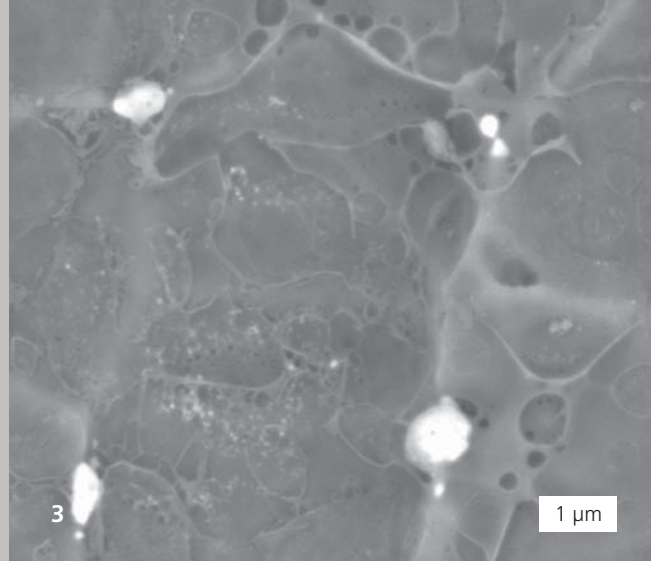
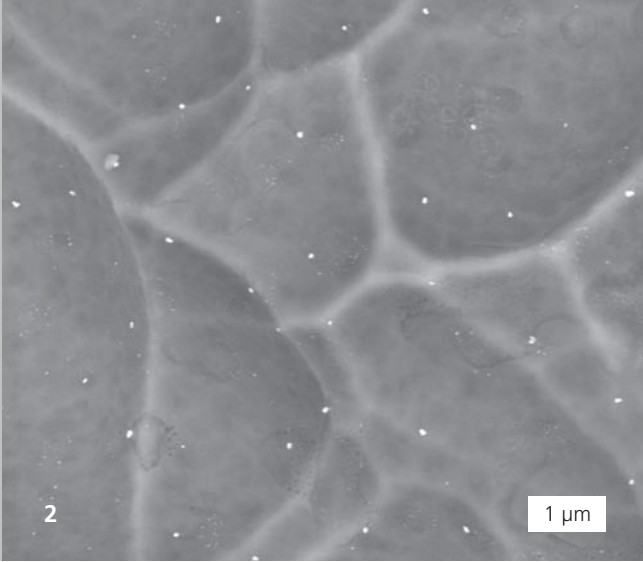

equilibrium and result in additional difficulties in the adjustment of the paste recipe. It is very important to control the individual kinetics. This can be done by using different silver powders, grain size distributions and glass additives. Each silver powder has a specific firing behavior depending on the temperature.

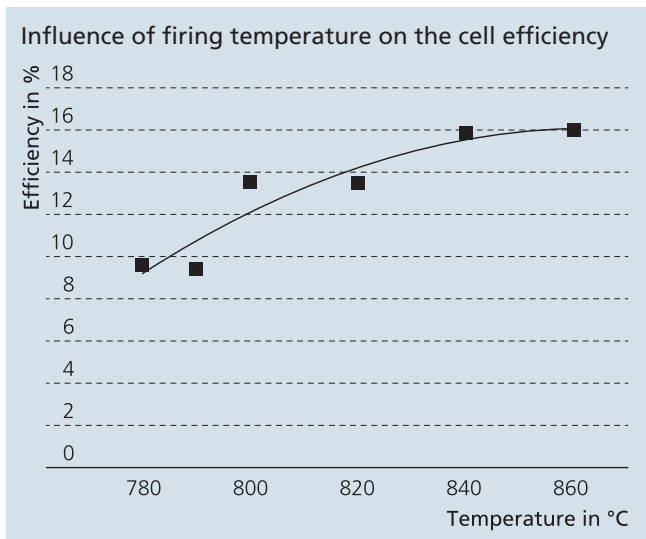

The focus of Fraunhofer IKTS developments is on lead-free front-side metallization pastes for silicon solar cells. The glass chemistry, in particular, has a significant impact on the silver transport and formation of silver colloids at the paste/wafer interface (Figure 2 and 3). Detailed etching investigation of promising glass composites point out that low firing temperatures result in numerous small well spread silver colloids (Figure 2). With increased firing temperatures/time the colloids coagulate and form direct contacts to the silicon surface (Figure 3). Type and quantity of silver colloid precipitation depend on the firing temperature and determine the contact resistance of the interface, and thus the efficiency of the solar cell (diagram above).

Services offered

Customized solutions for standard and high-efficiency architectures:

- Glasses with specific wetting behavior
- Optimized silver and paste recipes
- Masked-based printing: ultra-fine line screen printing, stencil printing, gravure printing
- Digital printing: aerosol and inkjet printing
- Electrical characterization
- Characterization of coating properties: adhesion, shear test, solderability, bondability
- Pre-aging characterization: thermal shock, humidity/heat

- 1 Cross-section of a fired contact finger of high aspect ratio.
- 2 Homogeneously distributed silver colloid precipitation at the silicon-silver interface uncovered by HNO_3 etching (glass A, $T = 890^\circ\text{C}$, FESEM image).
- 3 Coagulated silver colloid precipitation at the silicon-silver interface uncovered by HNO_3 etching (glass B, $T = 960^\circ\text{C}$, FESEM image).



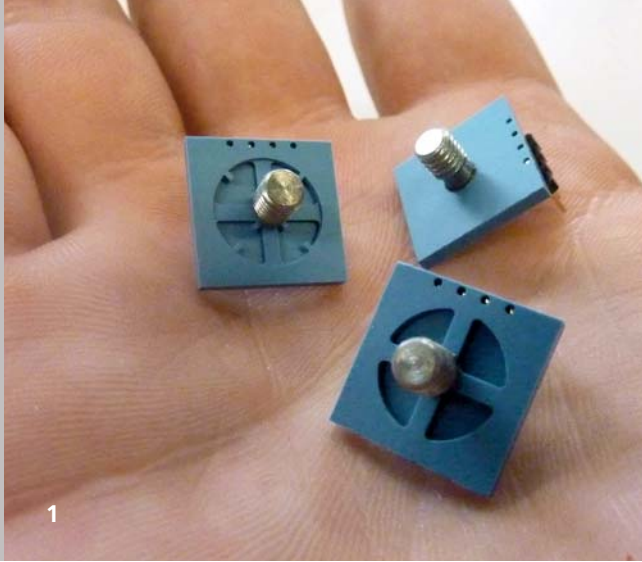

FORCE MEASUREMENT BY USING THE DEFORMATION OF 3D STRUCTURED CERAMIC BODIES

Dipl.-Ing. Christian Lenz, Dr. Steffen Ziesche, Dr. Uwe Partsch

Sensors for determining mechanical parameters such as force, pressure or acceleration are of great importance in our daily lives. Continuous miniaturization, higher measurement accuracy and long-term stability as well as increased functionality accompanied by a high price sensitivity are the latest trends for such measurement systems. In this context, micro-electro-mechanical systems (MEMS) are increasingly used. Besides the traditional silicon technology, the ceramic multilayer technology has also been established in this field. As the ceramic multilayer technology is based on the processing of single ceramic green tapes which are only laminated and fired in the final manufacturing step, it is possible to geometrically and electrically structure the single green tapes. By stacking these differently structured tapes, three-dimensional functional structures can be realized. The advantages of multilayer ceramics are their chemical and thermal stability, their simple, flexible and cost-effective manufacturing in multiple panels as well as the homogenous material sensor packaging.

Fraunhofer IKTS develops miniaturized force sensors in low-temperature cofired ceramics (LTCC). Compared to other ceramic multilayer systems (e.g. Al_2O_3 or ZrO_2), these ceramics provide an excellent combination of economic efficiency and mechanical material properties, and thus are particularly suitable as base material for miniature force sensors.

For the mechanical-electrical conversion of the measured quantity, the piezoresistive measuring principle is used due to its high accuracy, long-term stability and versatility. Therefore, piezoresistive thick-film resistors (TFRs) are utilized, which are deposited on a deformable body and connected to a Wheat-

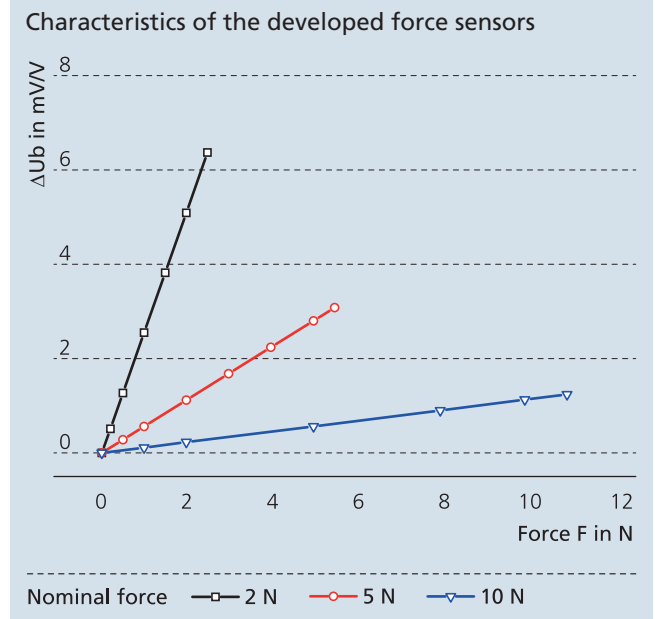

stone bridge. Here, piezoresistive TFRs provide a good compromise between high-strain sensitivity and temperature stability as compared to metal film or semiconductor strain gauges.

The deforming element is designed as a cartwheel structure with a reinforced center. This design ensures a high sensitivity in the measuring direction and a good robustness against shear loads. Furthermore, the reinforced center allows to assemble industry-related fasteners (e.g. M4 screws) which are used to detect tensile and compressive loads.

The sensor elements are manufactured in the standard technology for multilayer ceramics in a 4-inch multiple panel. In

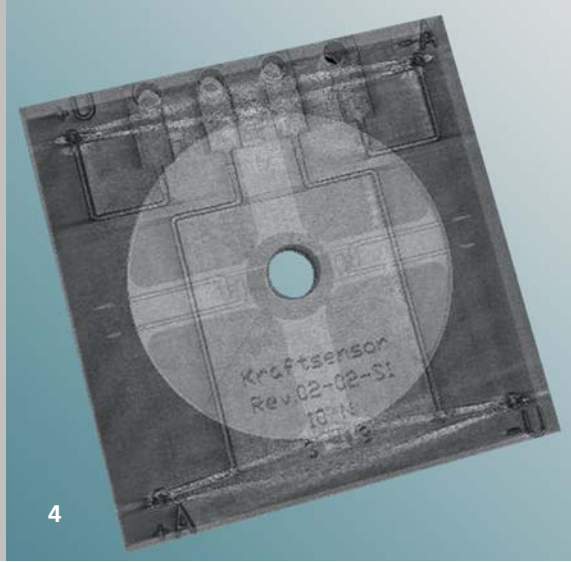
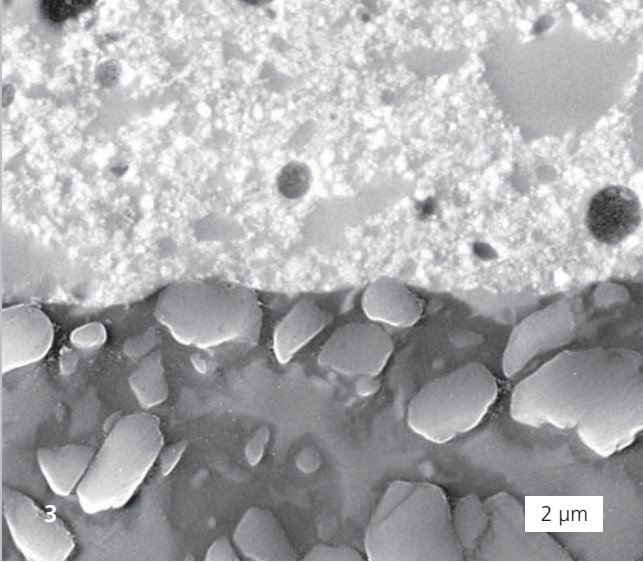

this way, 25 elements can be produced in parallel. Due to the flexible and cost-effective structuring capabilities of this technology (e.g. punching, laser cutting, screen printing), a high economic feasibility is given.

The characterization of the prototypes shows the characteristics presented in the table below and illustrates the potential of this technology for such applications.

Properties of the developed force sensors

Nominal load F_N	2 N	5 N	10 N
Offset voltage U_{Off} [mV/V]	< 15	< 32	< 130
Sensitivity S [mV/(VN)]	2.6	0.6	0.1
Linearity L [%FS]	< 0.6	< 0.4	< 1.0
TC sensitivity TC-S [%S/K]	-0.02	0.03	0.02

Future studies focus on the reproducibility of the sensor elements in multiple panels up to 8 inch. Moreover, technological and structural properties are under investigation to optimize the sensor elements. So, the design process as well as the yield will be further improved.

Services offered

- System design of mechanical sensors according to customer specifications
- Simulation and optimization
- Technology development, consultancy services, technology transfer to industry

Applications

- Test and assembling equipment
- Robotics
- Haptic systems

- 1 Force sensors for three nominal loads.
- 2 Processing in multiple panels.
- 3 Structure of a TFR on LTCC.
- 4 CT picture of a 10 N force sensor.

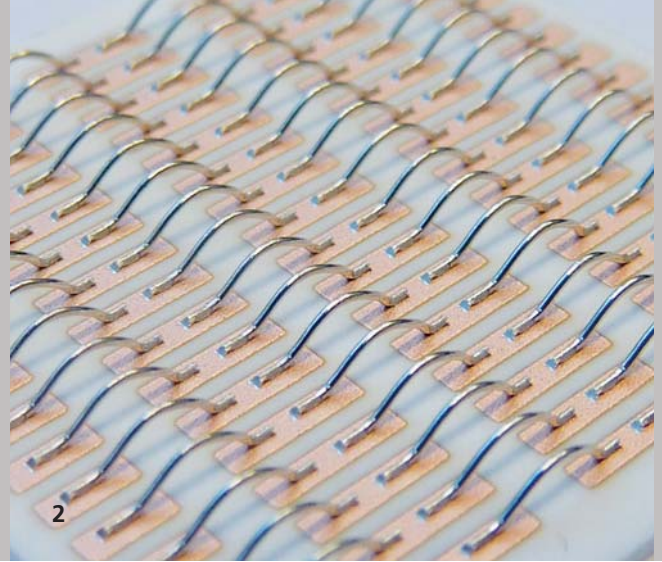
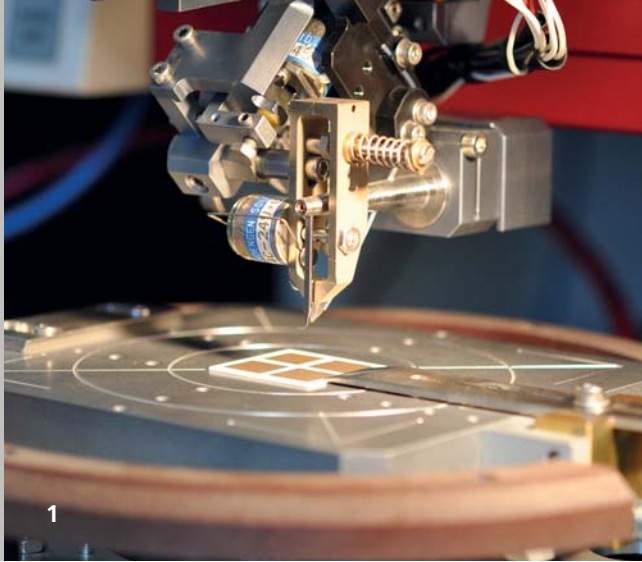

CERAMIC ELECTRONIC PACKAGING AND SYSTEMS INTEGRATION

Dr. Lars Rebenklau, Dr. Uwe Partsch

Besides the classic PCB and thin-film technology, electronic components and systems are often realized as ceramic hybrid modules. These modules consist of ceramic or glass-ceramic substrates on which e.g. conductor, insulator or resistor pastes are sequentially deposited. Subsequently, the functional layers are formed in a high-temperature process.

Compared to traditional epoxy-based PCBs, the main advantage of ceramic hybrid modules is their reliability particularly in harsh environmental conditions. Further advantages of ceramic circuit carriers result from advantageous physical properties such as high thermal conductivity as well as excellent dielectric properties (ϵ , $\tan \delta$). Additionally, they have good thermo-mechanical properties as compared with silicon.

Main applications of ceramic hybrid modules are e.g. electronic modules with very high performance and power dissipation as well as highly reliable modules with extended temperature range used in automotive and aerospace engineering.

At Fraunhofer IKTS, hybrid ceramic substrates are developed in both, standard thick-film and multilayer technology (LTCC and HTCC). For the development of complete modules in laboratory scale and for their integration into systems, a broad portfolio of typical packaging technologies (soldering, wire bonding as well as assembly and contact adhesive bonding) is available. For characterization of the electronic contacts, the necessary analysis technology (e.g. microstructure analysis/ phase composition, adhesion and shear strength) is provided.

Current projects focus on, e.g. selective soldering processes and heavy-wire and ribbon bonding for increased temperatures for ceramic high-performance modules.

Special equipment is available for selective soldering of electronic passive and active components. By using IR light, laser and induction heads, it is possible to heat and melt the solder up to temperatures of 750°C.

The advantage of this technique is that the compounds are locally and temporarily heated. Compared to standard alloying methods the microstructure formation of the solder joints and the alloying of the metallization can be better controlled. This results, e.g. in a higher shear strength of the solder joints or the possibility of formation of highly-conductive layers made of polymer substrates.

At Fraunhofer IKTS, the development of optimized contacting technologies is embedded in the development cycle of complete ceramic hybrid modules and sensors. This allows Fraunhofer IKTS to provide extensive expertise in material, technology and system development for multiple applications of ceramic hybrid technology.

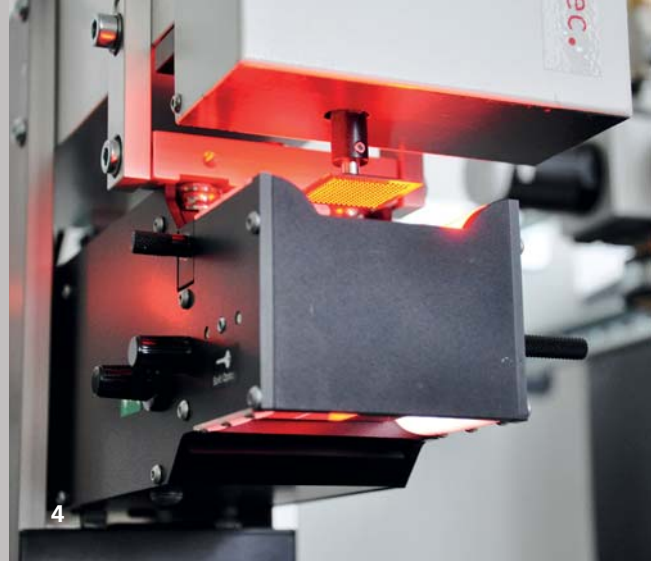
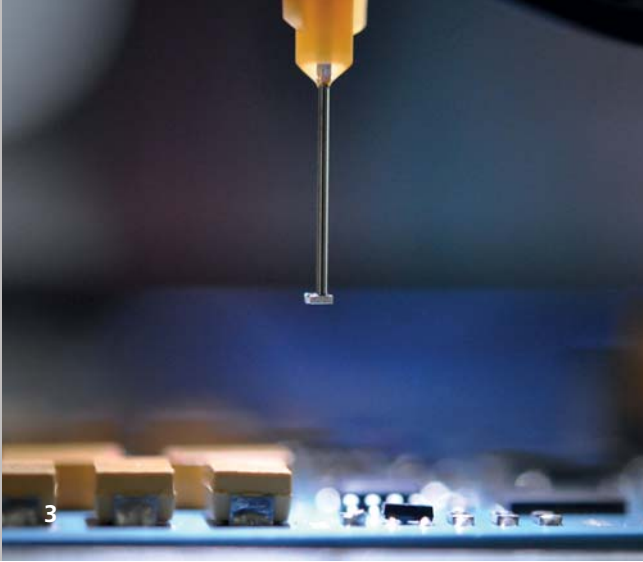

Services offered

Characterization of pastes, thick-film and multilayer-based components

- Rheological characterization of paste materials
- Determination of electrical parameters (sheet resistance, TCR, $\tan \delta$)
- Impedance and phase analysis in the frequency range from 1 mHz to 1 MHz
- Determination of maximum power loss density (short time overload, STOL)
- Design and construction of test stands for customer-specific measuring tasks

Circuit and component design

- Layout and construction of prototype modules and hybrid ceramic heating elements using the software systems HYDE and Altium Designer

Electronic packaging

- Parameter optimization of ball-wedge and wedge-wedge wire bonding method
- Characterization of bonding surfaces and wires
- Technological research on selective soldering (IR, laser, inductive)
- Assembly and conductive adhesives for increased operating temperatures

Reliability testing/failure analysis

- Thermal analysis of ceramic components using IR-thermography
- Failure analysis of thick films
- Thermal aging
- Characterization of mechanical properties of joints
- Non-destructive testing (X-ray, ultrasonic)

- 1 *Bond head.*
- 2 *Heavy-wire bonds.*
- 3 *SMT assembly.*
- 4 *Flip-chip bonder.*

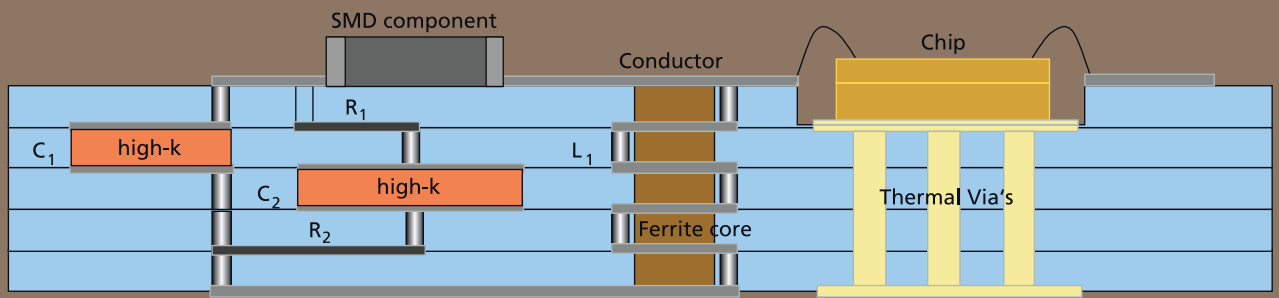

1

INTEGRATION OF FUNCTIONAL MATERIALS INTO CERAMIC MULTILAYER PACKAGES

Dr. Stefan Barth, Dipl.-Chem. Beate Capraro, Dipl.-Chem. Michael Hofmann, Dipl.-Phys. Ray Sikora

In the past, significant efforts have been made on the miniaturization of electronic devices, for example in the field of cellular phones or other portable devices. This process was pushed by the success that has been achieved with giant integration densities on chip level. In contrast, passive components are currently the most important bottlenecks in the upcoming miniaturization process of electronic devices. For this reason, there is an increasing demand to transfer this state-of-the-art on miniaturization and functionality to the superior integration level. Innovative approaches in the field of system integration have been considered as an indispensable tool to achieve such an objective. LTCC (low-temperature co-fired ceramics) as a ceramic multilayer packaging technology has been used for the development of 3D highly integrated electronic modules, marked by an excellent mechanical and thermal robustness. Integration of passive components into LTCC boards, however, is restricted to SMD components at the moment, limiting further miniaturization. Hence, the monolithic integration of functional materials into ceramic multilayer circuit boards is a straightforward approach to gain higher integration levels in multifunctional electronic modules.

The layout of such a ceramic multilayer board with integrated functional materials is shown in Figure 1. For this purpose, ultra-low sintering functional materials are required that are compatible with LTCC process conditions. The following materials are particularly interesting for this kind of application, and thus are subject of a joint project between Fraunhofer IKTS, the Jena University of Applied Sciences and the Ilmenau University of Technology:

- Low-loss high-k materials with low thermal coefficient of permittivity for the integration of high-performance capacitors
- Low-loss ferrite materials for the integration of frequency stable inductors
- NTC thermistors for high-sensitive temperature sensors
- PTC materials for self-regulating heaters and current-limiting resistors

The development of LTCC compatible materials is quite challenging, since it is necessary to decrease the sintering temperature of these functional materials from more than 1200°C down to 900°C in a way that the most important material parameters are kept stable. In contrast to standard LTCC materials, the above mentioned functional materials cannot be sintered completely at 900°C by means of an adapted glass additive which supports densification by the viscous flow of the softening glass, since higher amounts of glass completely degrade the functionality of these materials. The sintering temperature was reduced to 900°C by means of a modified chemical composition, sub-micron powders with enhanced sintering activity and highly-efficient sintering aids. By this way, a range of functional materials was obtained which can be sintered at the desired sintering temperature of 900°C (diagram on the top right) and which are compatible with standard silver metallization inks. Robust preparation technologies were successfully applied in order to scale-up the ceramic powder preparation route from laboratory scale to a pre-pilot scale, which was necessary for the development of a stable tape casting process. Integration of functional materials into ceramic multilayer boards requires adapted ceramic green

Shrinkage behaviour of different low sintering functional materials

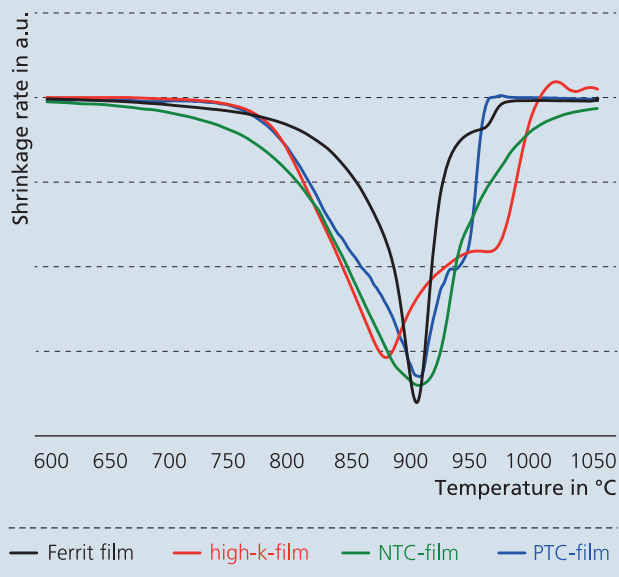

tapes which are compatible with standard LTCC process conditions. That means that it must be possible to process them by punching, screen printing, via filling and lamination. In order to achieve this objective, customized ceramic slurries were developed for every material mentioned above, and green tapes were cast that were easy to process. In order to investigate the performance of these materials, multilayer devices were pre-

R/T plot of a multilayer PTC resistor sintered at 915°C

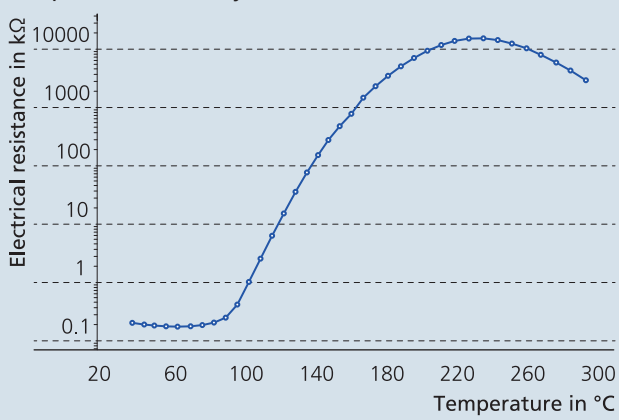

pared and sintered using standard LTCC process conditions. The diagram below shows the R/T plot of such a multilayer PTC resistor sintered at 915°C. The curve shows a typical PTC behavior comparable with conventional PTC materials sintered at higher temperatures.

Acknowledgments

The presented results were obtained in a joint project between the Jena University of Applied Sciences, the Ilmenau University of Technology and Fraunhofer IKTS. The project was financially supported by the Free State of Thuringia within the framework of the "ProExcellenz" program (FKZ: PE 214).

Services offered

- Development of customized and application-specific LTCC compatible materials
- Development of customized and application-specific slurries and green tapes
- Investigations on material and process compatibility
- Characterization of materials and components

1 Layout of a LTCC board with integrated functional materials.

SUBJECT AREA

BATTERY TECHNOLOGY

In the past years, Fraunhofer IKTS has made significant progress in the field of functional ceramics following its philosophy of considering ceramic materials and technologies not as something isolated, but in the context of their application along the entire value chain. Examples include applications in the field of energy technology such as solid oxide fuel cells or crystalline solar cells where functional ceramic materials were successfully developed into components and systems.

Ceramic materials and technologies are also an essential element of another application: electrochemical energy storage devices – also known as batteries. In this field, Fraunhofer IKTS has a broad scientific-technological basis and the various working groups are strongly connected to each other. The scientists work on different aspects of Li-ion batteries, sodium-based high-temperature and metal-air batteries or super capacitors. In the following articles, some examples of this developments are presented.

The deep understanding of the chemical-physical processes occurring in batteries is a prerequisite for the development of materials and products. On the one hand, Fraunhofer IKTS develops methods for microanalytical structure characterization as well as for electrical and thermal characterization. On the other hand, new methods are developed by means of which local caloric effects, for example, can be studied spatially resolved and in-situ during the charging/discharging process. This provides additional information, when comparing different electrode materials. Additionally, the modeling of the cell behavior on different levels provides essential knowledge regarding the development of an optimized cell design and system environment which compensates effects that limit the cells' life time.

At Fraunhofer IKTS, materials and slurries for Li-ion batteries are developed on different levels – starting in the laboratory and ending in a pilot plant. First, the focus is on newly or optimized electrode concepts. With an increasing scaling factor, aspects of manufacturing with regard to high-throughput processes are considered. To accomplish this, the cooperation with industry partners such as ThyssenKrupp System Engineering GmbH is of great importance.

Battery concepts, which are particularly interesting for large stationary applications, are developed at the Center for Energy and Environmental Chemistry Jena (CEEC Jena) which was established by Friedrich Schiller University Jena (FSU) and Fraunhofer IKTS last year. In this context, a new researcher's group has been established which develops ceramic materials for, e.g., sodium-based high-temperature and metal-air batteries.

oehwald
sch Group



cientlab
electronic systems





SPATIALLY RESOLVED IN-OPERANDO TEMPERATURE MEASUREMENT

Dipl.-Ing. Christian Heubner, M.Sc. Christoph Lämmel, Dr. Michael Schneider

Li-ion secondary batteries are one of the most promising technologies to challenge the continuously increasing demand for energy storage devices for mobile high-power and high-energy applications. Applications in the field of electric mobility are currently limited by too low energy densities as well as temperature sensitivity and heat generation during rapid charge and discharge. A detailed understanding of the electrochemical processes taking place in the battery is the basis of tailored material development to overcome the current limitations.

The “Electrochemistry” working group at Fraunhofer IKTS offers a wide range of electrochemical methods to investigate electrode materials for Li-ion batteries. The investigations

focus on electrochemical processes during charge and discharge as well as the behavior of the materials. Beyond that, complementary and combinational in-operando and online measurement techniques are used in experimental setups developed in-house. This allows for the investigation of fundamental mechanisms and the characterization of materials.

To overcome the current problems concerning the heat generation in Li-ion batteries, a fundamental understanding of the heat generating processes and mechanisms is essential. Therefore, an experimental setup for spatially resolved temperature measurements across the interfaces anode-separator/electrolyte-cathode is developed.

Schematic configuration and positioning of thermocouples for spatially resolved temperature measurement

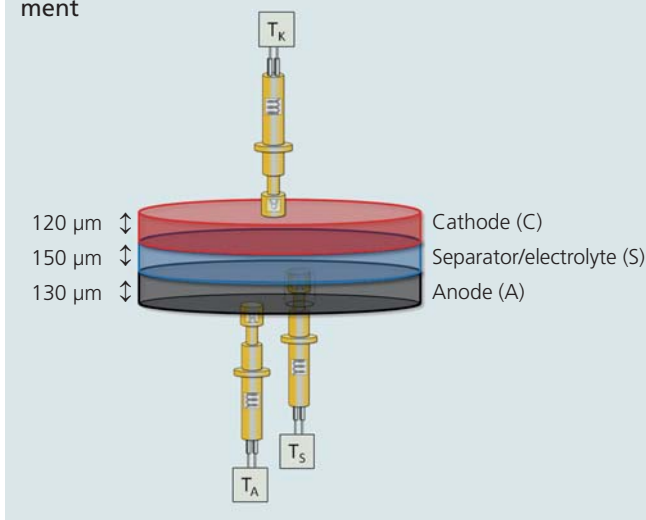
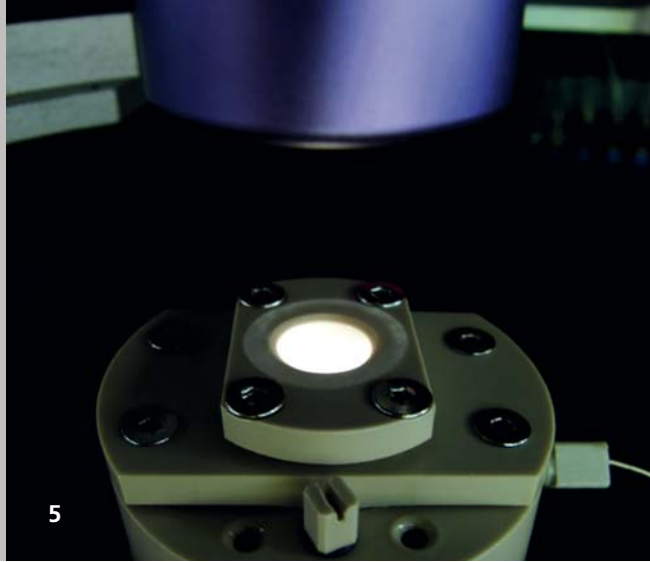
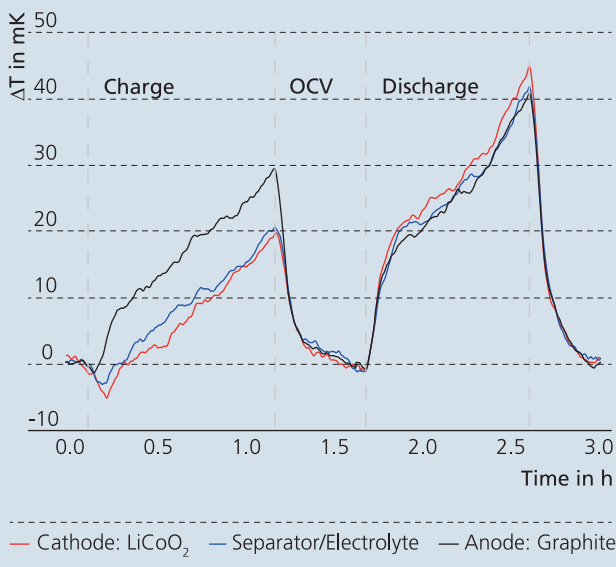

Figure 1 shows a schematic drawing of the electrode stack and the arrangement of thermocouples for spatially resolved temperature measurements. In contrast to standard integral measurement techniques this experimental setup enables the localization, identification and differentiation of heat sources and sinks in the electrochemical system. Figure 2 shows the results of spatially resolved temperature measurements on a Li-ion battery during a charging-discharging cycle. At the beginning of the charging process, differences in the temperatures of anode and cathode are observed. The removal of lithium from LiCoO_2 leads to a decrease of the temperature in the cathode area. Contrarily, the lithium intercalation in the graphite anode is exothermic. Kinetic limitations at the electrodes and the separator cause a temperature increase by Joule heating.



Spatially resolved temperature measurement during charging (C/2) and discharging (C/2) of a Li-ion battery cell



In the course of charging, the temperature development at the cathode becomes positive due to thermal relaxation processes. Nevertheless, the endothermic reaction heat of the cathode reaction leads to a stationary temperature gradient between anode and cathode. Consequently, a stationary heat flux from the anode to the cathode occurs. After the charging process, the open circuit voltage of the cell is measured and gradients of temperature, concentration, etc. relax. At the beginning of the discharge process, the temperatures of anode separator and cathode increase rapidly. In the cathode area, the heat of electrochemical reactions and Joule heating are aligned and add up. The heat of the anode reaction is substantially lower than that of the cathode reaction. Heat development of the cell is dominated by the cathode throughout the whole discharge process.

The combinational approach enables correlations between the electrochemical behavior and the physical properties of the different battery components. The knowledge of these interac-

tions is essential for various working groups at Fraunhofer IKTS to expedite the development of new materials and manufacturing technologies more efficiently. Furthermore, the measurement results reveal thermodynamic data and kinetic parameter which can be used in in-house cooperation with the "Modeling and Simulation" working group.

Services offered

- Electrochemical and spectroscopic characterization of electrode materials and electrolytes
- Determination of water content in electrode materials and electrolytes (Karl-Fischer titration)
- Investigation of electrochemical mechanisms

- 1 *Glovebox.*
- 2 *Screw cells for electrochemical material characterization.*
- 3 *In-house development: Electrochemical experimental setup with spatially resolved in-operando temperature measurement.*
- 4 *Karl-Fischer titration for the determination of water content.*
- 5 *Measuring cell for in-situ Raman spectroscopic investigations.*

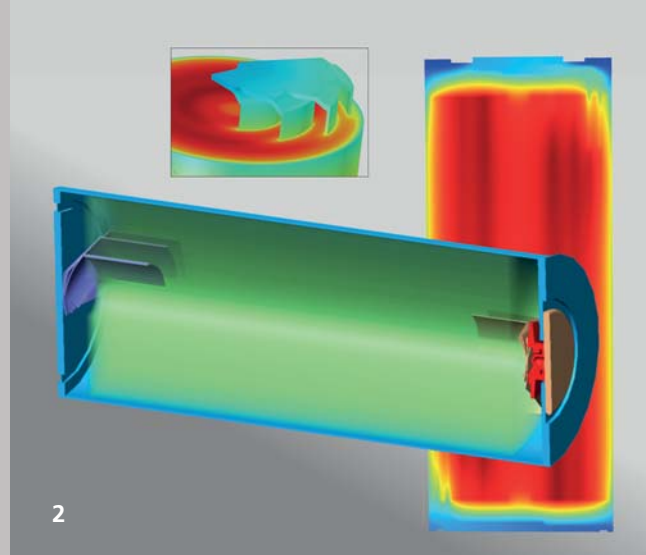
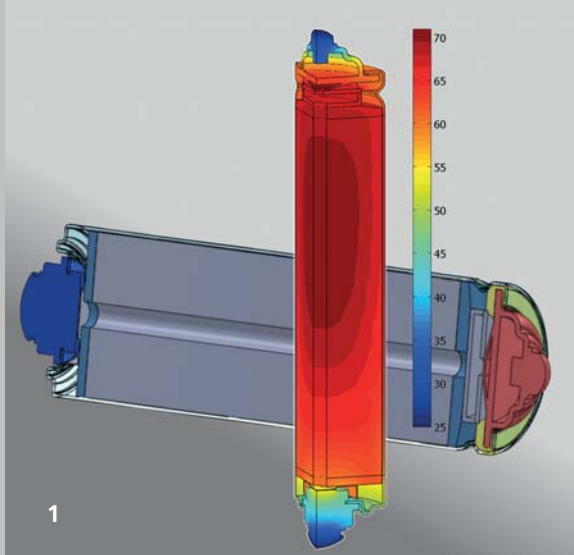

THERMAL 3D MODELING OF LITHIUM-ION CELLS

Dr. Wieland Beckert, Dipl.-Ing. Christian Freytag

An advanced thermal management system is a necessary prerequisite for the efficient, safe and durable operation of high-performance energy storage systems, taking into account the strong bidirectional interactions between the thermal and the electrochemical processes. Mathematical-physical modeling has proven to offer valuable tools for analysis, design and optimization of such systems in the practical development process. The monitoring and the prevention of local overheating (thermal hot spots) inside the cell form an essential aspect of thermal management. Modeling tools provide unique means to explore the internal thermal and electric conditions during operation inside a virtual battery cell, to which experimental access is restricted during operation of real cells.

A 3D finite element simulation for different configurations of Li-ion cells was implemented and analyzed at Fraunhofer IKTS as part of the SAB project "LionHeart" in collaboration with the IAV GmbH Chemnitz. Based on the commercial multi-physics program code COMSOL a modeling strategy was elaborated that accounts for the essential details of the geometrical functional elements (winding body, housing, contacting tabs) and the strong, local coupling of the thermal and electrical processes on the one hand, but takes advantage of efficient model reduction concepts (homogenized composite approach of winding zone, semi-empirical approach for local electrical characteristics) on the other hand. The compromise allows for a detailed insight into the thermal behavior of battery cells

with consideration of both design details and electrochemical specifications of the cell material also for the case of dynamic loads combined with moderate computing performance requirements. Therefore, the modeling is not restricted to high-performance computer systems and the approach still has capacity reserves to be extended towards, for instance, the analysis of multiple cell assemblies.

The model was applied to different geometry variants of cylindrical Li-ion cells. A first cell type was characterized by an evenly distributed electrical contact of the winding body by help of pressure plates at both end faces (Figure 1). This design realizes a very uniform contact of the cell laminate along the film edges, while the total contact surface remains limited to the area of the end faces. The concept is, therefore, rarely used in high-performance cells. The model could take advantage of the axisymmetric geometry. The winding body – due to a purely axial current flow distribution – could be directly implemented as a radial-symmetric electric and thermal composite. The analysis of a thermally stationary load case revealed no contact related thermal hot-spots in the electro-chemically active domain even for very high current loads ($I = 67 \text{ A}$).

A commonly used alternative design uses separated contact fingers embedded between individual winding layers (Figure 2). Although this concept offers the chance to increase the elec-

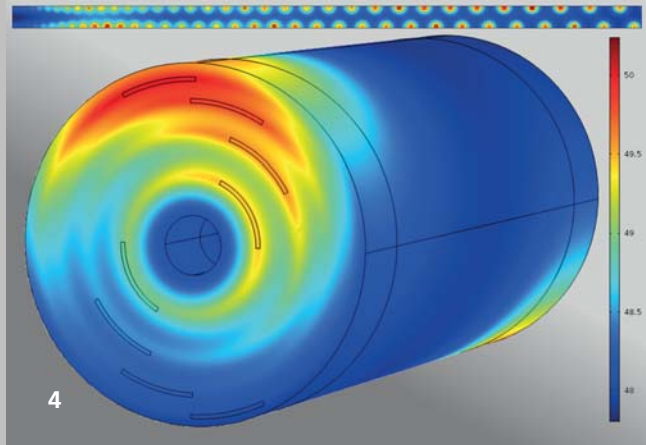
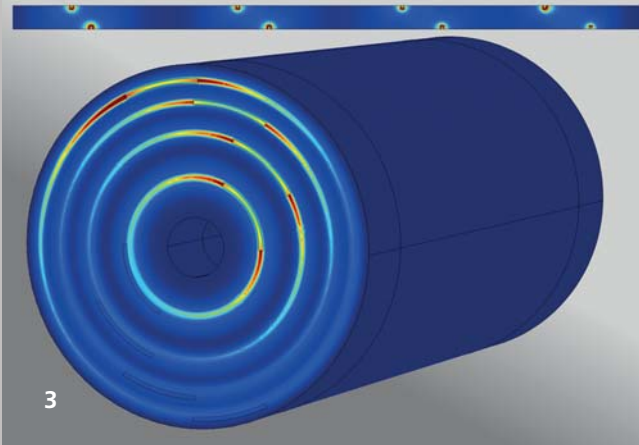

trical contact area, the contacting of the cell laminate appears more localized and non-uniform. This results in strong current density concentrations and locally increased heat production in the cell laminate regions, surrounding the finger contacts (Figure 3). While under thermal stationary assumptions (constant current load) the local heat can diffuse to the neighboring windings without forming significant temperature gradients, the analysis clearly showed thermal hot-spots for a dynamic load case with short, strong current pulses ($I_{\max} = 95 \text{ A}$; $\Delta t = 6 \text{ s}$), due to the thermal inertia of the winding structure (Figure 4). A direct homogenization of the electric problem for the winding body in a 3D composite frame turned out not to be feasible due to numerical problems with the representation of helical current flow along the winding contour on coarse meshes. Instead a hybrid approach with a 2D formulation of the electric problem in the 2D frame of the unrolled cell laminate combined with a 3D composite formulation for the thermal problem was implemented for the winding body. The coupling and the mapping of the 2D and 3D model and their quantities could be completely realized within the flexible FE code COMSOL.

The presented model approach allows for a detailed analysis of the influence of geometrical parameters and material specifications on the thermal and electrical behavior within the interior of Li-ion cells during operation mode. Possible practical applications of the model – beyond its use for cell design optimization – are seen in the implementation of a “Virtual Thermal Battery Lab”, for instance, to identify the limits of operation for specific cells in high-performance applications or for the calibration of less detailed models in dynamic real-time simulations. Another specific application is to assist the development of an internal temperature sensor for battery cells in the “Energy Storage Systems” working group to find an opti-

mal positioning and to analyze possible disturbing effects of the sensor. Another objective will be to implement a thermal battery model with detailed electrochemistry as part of an internal collaboration with the “Electrochemistry” working group.

Services offered

- Implementation and analysis of multiphysics models for the thermal behavior of customer-specific battery cell designs
- CFD analysis of the cooling of battery packages

- 1** Model and exemplary result for the temperature field of a Li-ion cell design with planar contact plate.
- 2** Model geometry and temperature distribution for a Li-ion cell design with separated contact fingers.
- 3** Thermal source density distribution in the winding structure of a cell design with finger contacts.
- 4** Temperature distribution in the winding structure for pulse current load.





MATERIAL AND SLURRY DEVELOPMENT FOR LITHIUM-ION BATTERIES

Dr. Marco Fritsch, Dr. Nikolai Trofimenko, Dr. Christian Bretthauer

Electrical energy storage systems are a fundamental component for a sustainable energy supply of the future. The Li-ion battery technology plays a central role in research and development to realize the projected goals in energy policy, for example, decentralized energy storage and electromobility. Aspects of safety, durability and costs of battery cells have to be investigated. At Fraunhofer IKTS, functional powders are processed to thin electrode foils for battery cells using material-scientific methods and state-of-the-art manufacturing solutions. Ceramic technologies play a crucial role for the synthesis and dispersion of powders, preparation of casting slurries and coating of the electrodes in a continuous tape casting process. In cooperation with industry partners the entire process chain of modern battery cell manufacturing is demonstrated at Fraunhofer IKTS. Complex correlations between raw material selection, process technology and resulting battery properties are studied as well as the upscaling of the production process.

Li-ion batteries for stationary and mobile systems differ in the required energy and power density. For these electrode concepts different active materials are used. To reach high energy densities new lithium nickel cobalt manganese (NCM) and lithium nickel cobalt aluminum oxide (NCA) materials are synthesized at Fraunhofer IKTS. Simultaneously, the production costs will be reduced and the environmental compatibility will be increased due to a reduction of the heavy metal content. New materials of global market leaders, e.g. based on LiFePO_4 , are characterized as well, and specified in terms of processing and performance properties. Due to variable powder properties like morphology, electrical conductivity and particle sizes,

the slurry recipe as well as the slurry preparation technology have to be individually adapted to the raw material powder. For this research, well-known characterization methods from ceramic technologies are applied as well as new methods are developed and standardized to evaluate the electric sheet resistivity, adhesion of the coating to the metal collector, and volume porosity of the electrode.

Due to the integration of carbon black in the electrode composite, the electric sheet resistivity of LiFePO_4 cathodes is increased by several orders in magnitude as compared to the raw material powder. In this way, the power density of such electrodes is significantly improved.

Electrode casting slurries for Li-ion batteries

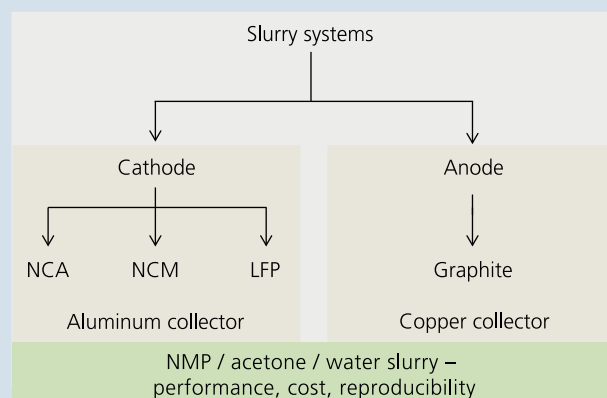

NCA – Lithium nickel cobalt aluminum oxide
 NCM – Lithium nickel cobalt manganese oxide
 LFP – Lithium iron phosphate

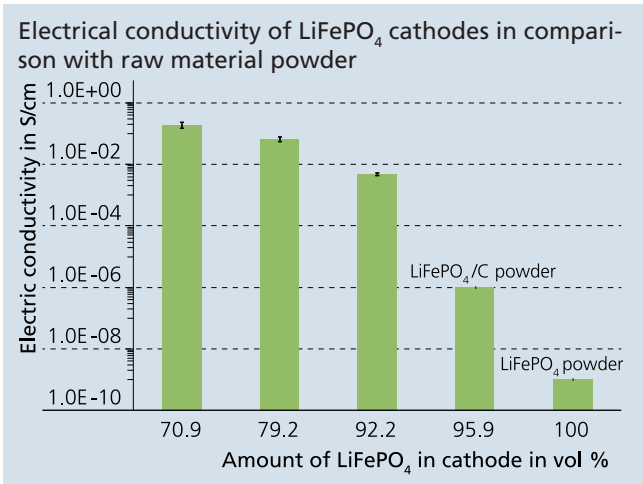
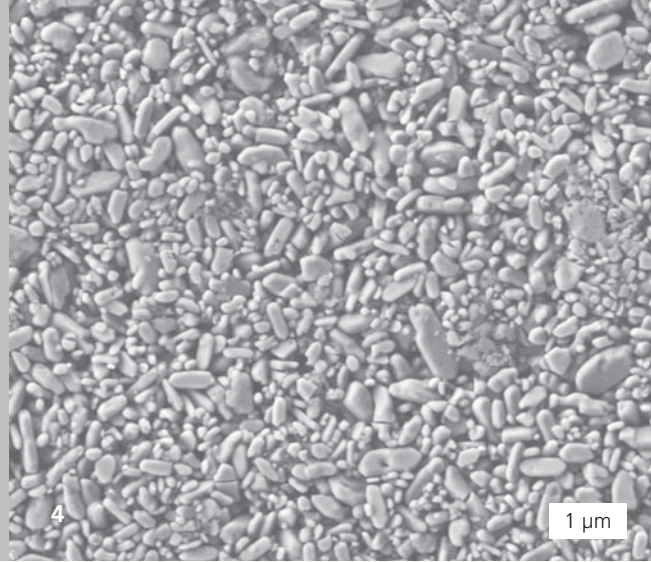
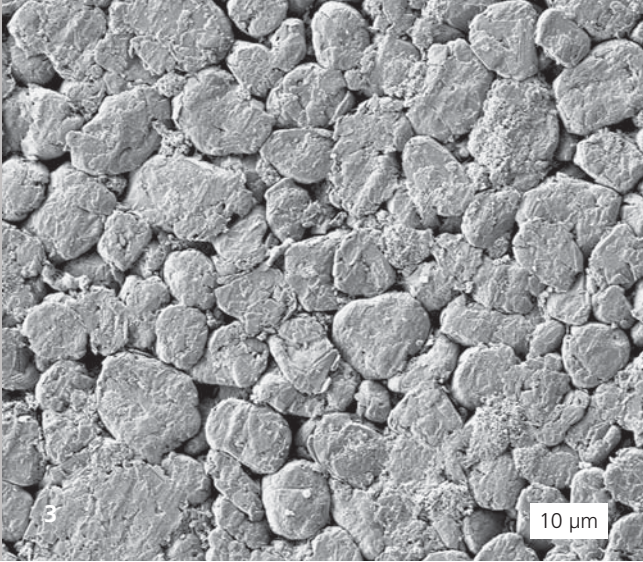

porosity of the anode after calendaring, residual water content and scaling of the slurry batch is evaluated by anode capacity, cell formation and cycle life.

With rising market share of such energy storage devices, questions arise concerning the cost effectiveness and environmental friendly electrode manufacturing as well as the recycling of battery components. Electrode-water based slurry systems have already established in industry for anodes, but N-methyl-2-pyrrolidone (NMP), which is classified as toxic, is still used for cathode electrodes. Therefore, water-based cathode slurries with various organic carriers are investigated at Fraunhofer IKTS.

The design of the graphite based anodes depends on the individual battery concept. The necessary cell balancing between cathode and anode is possible due to an adjustment of parameters like anode thickness and density. Previous results demonstrate that for the variety of commercial available graphite powders, which differ in synthesis and particle morphology, the processing has to be adapted to the individual raw material. The influence of various mixing technologies,

Furthermore, it is the aim to reduce energy consumption in the electrode drying step resulting in reduced production costs. Associated questions concerning the resulting electrode quality, stability of the cathode oxide materials and the electrode performance are currently under examination.

Services offered

- Recipe formulation of slurries for Li-ion batteries
- Casting technologies for electrode foils
- Evaluation of the processability and performance of active materials
- Microscopic, electrochemical and mechanical characterization of thin electrodes
- Laboratory-scale production and up-scaling for pilot-plant solutions

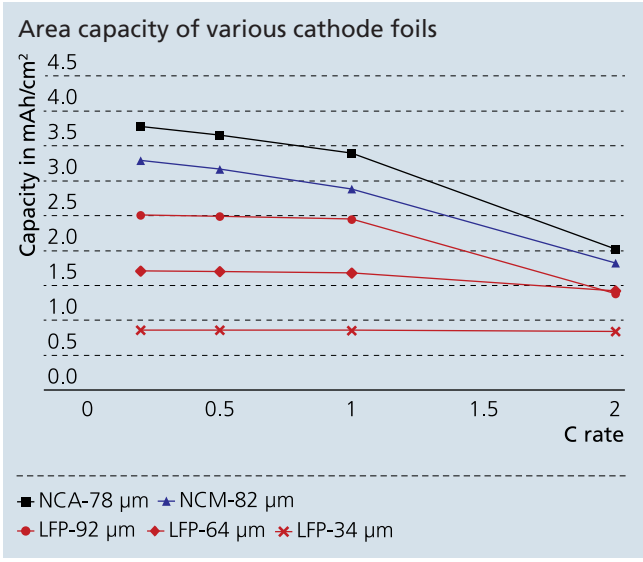

- 1 Slurry development.
- 2 Coating of the electrode.
- 3 Graphite anode.
- 4 Lithium-iron-phosphate cathode.



ELECTRODE MANUFACTURING FOR LITHIUM-ION BATTERIES ON PILOT SCALE

Dr. Mareike Wolter, Dipl.-Ing. Stefan Börner, Dr. Uwe Partsch

For the production of Li-ion batteries, the technology development on pilot scale is an important link between basic research on laboratory scale and industrial process development. Aside from the up-scaling and optimization of coating and other manufacturing processes, topics such as electrode handling in the process, design of the production environment as well as the realization of efficient process monitoring are essential for an efficient and reproducible battery manufacturing.

In 2012, ThyssenKrupp System Engineering GmbH and Fraunhofer IKTS opened a pilot plant for battery production in Hohenstein-Ernstthal to jointly work on the topics mentioned before. There, the scientists have the opportunity to study all relevant process steps (slurry preparation/characterization, electrode coating, calendaring, cutting of coated electrode foils, assembling of battery, filling of electrolyte) (see figure below).

Currently, central activities are focused on the publicly funded "LiFab" project with ThyssenKrupp System Engineering GmbH, Fraunhofer IKTS, KMS Technology Centre GmbH and AWEBA Werkzeugbau GmbH as project partners. Within the project, Fraunhofer IKTS analyzes the process chain up to the process step of calendaring (anode/cathode). The transfer of Fraunhofer IKTS know-how in terms of particle design, slurry preparation and electrode coating is an important prerequisite for the project's success.

For slurry preparation, different mixing equipment (dissolver, planetary mixer, kneader) is available. Energy input and mixing time are process parameters by means of which particle stability and degree of dispersion can be defined.

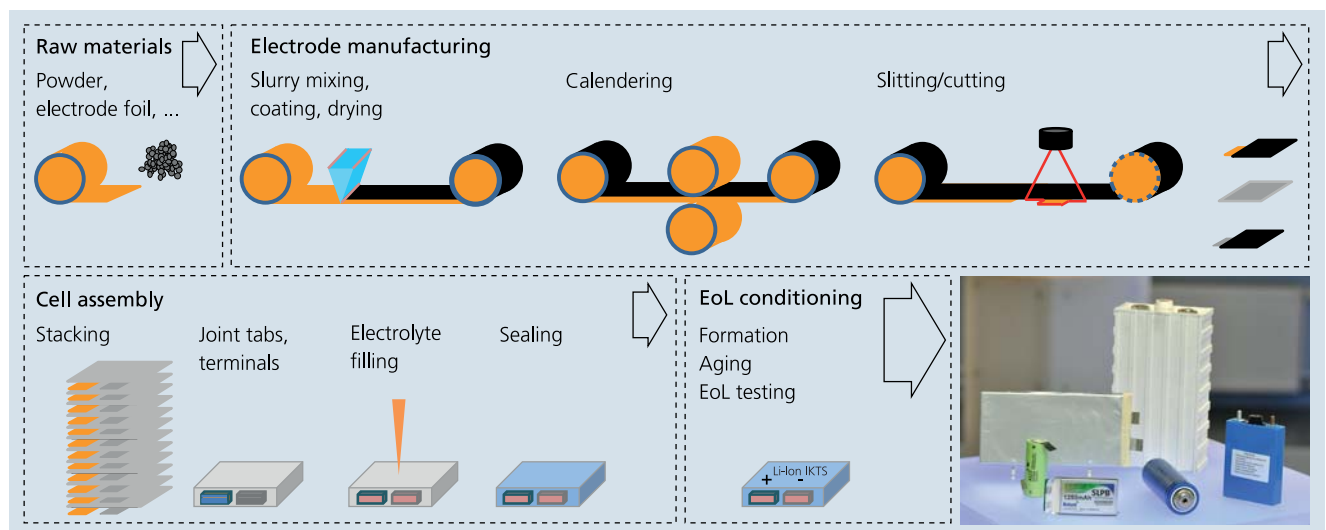



Another focus is on comparing and optimizing efficient and cost-saving coating technologies (doctor blade, comma bar, slot die) by means of which the electrode slurries are applied on aluminum or copper foils of a few microns thickness. Here, it is the aim to realize high casting speeds, a homogeneous and reproducible layer thickness as well as defect-free and adhesive electrode layers. The operating characteristics as well as long-term stability of the battery are mainly influenced by the morphology of the electrode foils.

Choosing suitable coating, drying and calendaring conditions is essential for the porosity and mechanical integrity of the coating, and thus for the electrical properties of the electrode foils. In order to be able to quantify these foils in an early stage of production, the electrode samples are built into button cells and analyzed.

The selection of the slurry recipe in connection with the coating weight adjusted during coating determines whether a cell has so-called high-power or high-energy characteristics. The diagram below shows for LiFePO₄ cathodes (LFP) with increasing coating weight, meaning higher storage capacity, that the capacity is not available completely from thicker electrodes

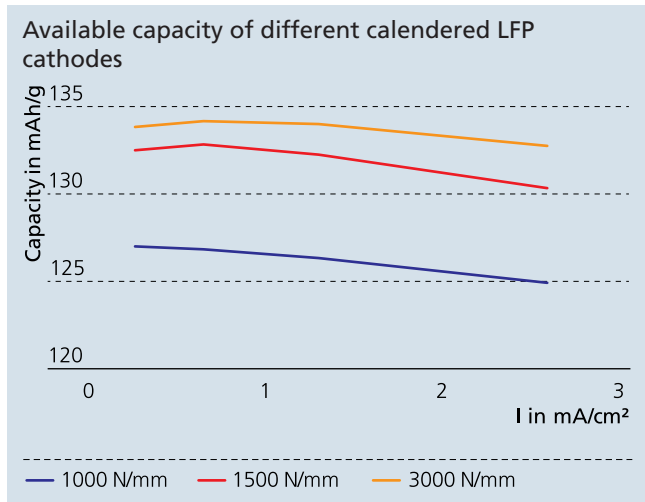
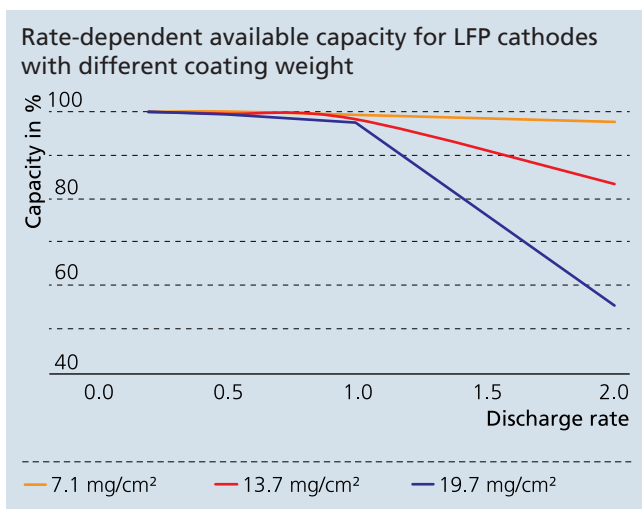

at increasing discharge rate (C rate). Additionally, the degree of calendaring determines, particularly for active materials with a low conductivity such as LFP, to which extent the gravimetric capacity is available during discharging. A sufficient high packing density for LFP particles is only possible at a comparatively high degree of densification, e.g. with the appropriate surface load during calendaring (see diagram above).

The pilot plant is not only used for publicly funded projects but also available for other industry partners in order to carry out material tests or to optimize processes. The expertise of the LiFab consortium in mechanical engineering allows for comprehensive adjustments of the research equipment according to customer requirements.

- 1 Opening of the battery pilot plant.
- 2 Mixing tests.
- 3 Electrode coating.
- 4 Drying in the coater.





CERAMIC MATERIALS FOR STATIONARY ELECTRICAL ENERGY STORAGE

Dr. Matthias Schulz

The development of renewable energy sources and the decreasing importance of fossil and nuclear energies lead to completely new requirements for the existing power grid. The geographic and temporal mismatch between energy generation and consumption requires adapted grid architectures. Electrochemical stationary power energy storage systems are one basic component of these new grids. Because of their adjustable properties advanced ceramics already play an important role in different battery technologies. At Fraunhofer IKTS, research activities concerning the following battery types are under development:

- Sodium-based high-temperature batteries
- Metal/air batteries based on ceramic separators and catalysts

Sodium-based high-temperature batteries

Based on the developments for the e-mobility branch in the 1980s and 1990s, adjusted sodium-based high-temperature batteries (Na/S and NaNiCl₂) are developed for stationary applications. The sodium ion conductor Na-β" alumina is the basic component of these batteries. By systematically varying the ceramic synthesis, the mineralogical, structural and electrochemical material properties of the ceramics are improved. Different raw materials and ceramic technologies are used in this process.

High-temperature test cells are developed and used to characterize the material performance. In this way, the conductivity for sodium ions and electrochemical processes in a working battery cell can be determined and analyzed.

Promising Na-β" alumina materials detected by this method will be used for further ceramic processing and shaping to electrolytes for large battery systems. In contrast to e-mobility applications, the design of the ceramic electrolyte will be defined by requirements of the targeted stationary application. In this respect, it is the main objective to adapt the energy and power density of the ceramic electrolyte, battery cell and battery system.

Phase composition of Li-stabilized Na-β" alumina for different temperatures

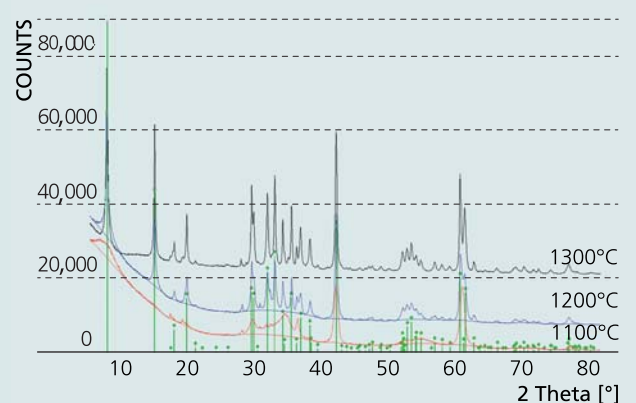



3

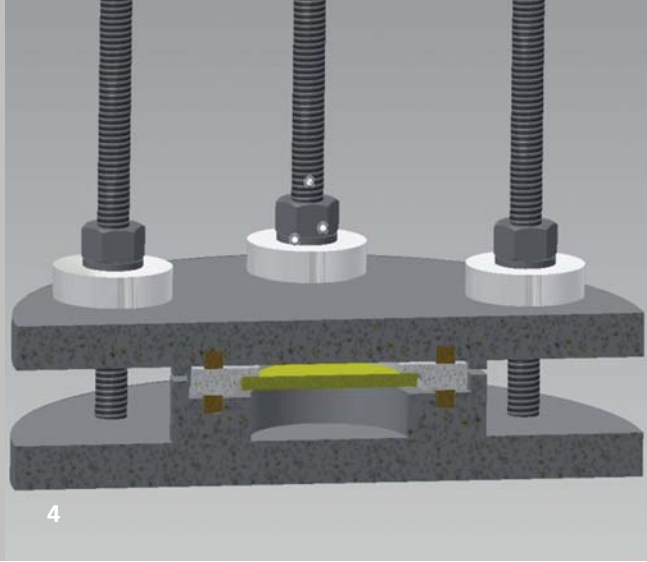

4

Metal/air batteries

Metal/air batteries are characterized by their simple and robust design as well as a particularly high energy density. Compared to other systems, only the metal anode is part of the battery and contributes to the chemically active battery mass while atmospheric oxygen is the active cathode reactant.

At Fraunhofer IKTS, Zn/air batteries based on ceramic separators and catalysts are under development for stationary applications. The oxygen reduction cathode is the key component and responsible for the battery performance. It typically consists of a catalyst embedded in carbon combined with a metallic current collector. At Fraunhofer IKTS, mixed oxide ceramic catalysts are developed and applied on ceramic separators in combination with porous metallic structures. First experimental results reveal low excess voltage and high open circuit potential of 1.55 V. These non-optimized battery cells have a current density of about 20 mA/cm² at a voltage of 1 V. By a further optimization of the cathode material and structure, a significant increase in power density and cell performance is expected.

Acknowledgments

The European Union and the European Social Fund (ESF) as well as the Free State of Thuringia are acknowledged for their financial support (project number: 2011 FGR 089).

Charge/discharge of a NaNiCl₂ micro test cell at 300°C

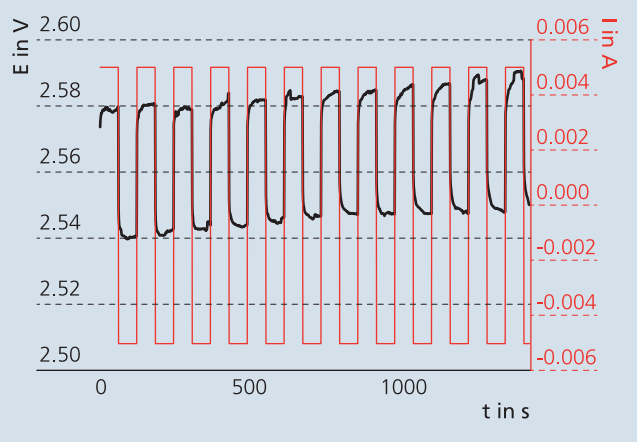

- 1 NaNiCl₂ micro test cell in a glove box.
- 2 Sintered Na-β" alumina disks.
- 3 Working in a glove box.
- 4 3D model of a planar high-temperature battery cell for lab-scale tests.



COOPERATION IN GROUPS, ALLIANCES AND NETWORKS

Scientists at Fraunhofer IKTS are active in numerous thematically oriented groups, networks and associations. Our customers benefit from this by having a coordinated range of joint services available to them.

Membership in Fraunhofer Groups, Alliances and Networks

	DRESDEN-concept e.V.
	Dresden Fraunhofer Cluster Nanoanalysis
Association for Manufacturing Technology and Development e.V. (GFE)	Energy Saxony e.V.
Association of Electrochemical Research Institutes e.V. (AGEF)	Ernst Abbe University of Applied Sciences Jena, university council
Association of German Engineers (VDI)	European Powder Metallurgy Association (EPMA)
Association of the Thuringian Economy e.V., Committee of Research and Innovation	European Research Association for Sheet Metal Working e.V. (EFB)
Association of Thermal Spraying e.V. (GTS)	Expert Group on Ceramic Injection Molding (Working Group in the German Ceramic Society)
BioMeT Dresden Network	Expert Group on High-Temperature Sensing Technology in the German Society for Materials Science e.V.
Carbon Composites e.V. (CCeV)	Fraunhofer Adaptronics Alliance
Ceramics Meeting Point in Dresden	Fraunhofer Additive Manufacturing Alliance
DECHEMA – Society for Chemical Engineering and Biotechnology e.V.	Fraunhofer AdvanCer Alliance
DKG/DGM Community Committee	Fraunhofer Battery Alliance

Fraunhofer Energy Alliance	NanoMat – Supraregional Network for Materials Used in Nanotechnology
Fraunhofer Materials and Components Group – MATERIALS	Nanotechnology Center of Excellence for “Ultrathin Functional Layers“
Fraunhofer Nanotechnology Alliance	ProcessNet – an Initiative of DECHEMA and VDI-GVC
Fraunhofer Numerical Simulation of Products, Processes Alliance	Research Association for Diesel Emission Control Technologies e.V. (FAD)
Fraunhofer Sensor Network	Research Association on Welding and Allied Processes of the German Welding Society (DVS)
Fraunhofer Water Systems Alliance (SysWasser)	Silicon Saxony e.V.
German Ceramic Society e.V. (DKG)	Society for Knowledge and Technology Transfer of TU Dresden mbH (GWT)
German Society for Materials Research e.V. (DGM)	TransNanoPowder Information and Consulting Center
International Energy Agency (IEA) Implementing Agreement on Advanced Fuel Cells	
International Zeolite Association	
Materials Research Network Dresden e.V. (MFD)	
Meeting of Refractory Experts Freiberg e.V. (MORE)	
Micro-Nanotechnology Thuringia e.V. (MNT)	

THE FRAUNHOFER MATERIALS AND COMPONENTS GROUP – MATERIALS

Fraunhofer research in the field of materials science and technology covers the entire value chain from the development of new materials and the improvement of existing ones to manufacturing technology on a semi-industrial scale, the characterization of materials' properties and the assessment of their performance. This work extends to the components produced from the materials and their performance in systems.

In addition to experimental tests in laboratories and pilot plants, numerical simulation and modeling techniques are applied in all these areas. The Fraunhofer Materials and Components Group – MATERIALS encompasses the entire field of metallic, inorganic-nonmetallic, polymer and sustainable materials as well as semiconductor materials.

The Group concentrates its expertise in the fields Energy & Environment, Mobility, Health, Machinery & Plant Engineering, Construction & Living, Microsystems Technology, and the Safety business sector. System innovations are achieved by means of tailor-made material and component developments and customer-specific performance assessment.

Key aims of the Group are

- To increase safety and comfort and to reduce the consumption of resources in transport, mechanical engineering and plant construction
- To raise the efficiency of systems for generating, converting and storing energy
- To improve the biocompatibility and functioning of materials used in medical engineering and biotechnology
- To increase the integration density and improve the utility properties of components in microelectronics and microsystem technology

- To improve the use of raw materials and the quality of the products made from them

The Group comprises the Fraunhofer Institutes for

- Applied Polymer Research IAP
- Building Physics IBP
- Structural Durability and System Reliability LBF
- Chemical Technology ICT
- Manufacturing Technology and Advanced Materials IFAM
- Wood Research, Wilhelm-Klauditz-Institut, WKI
- Ceramic Technologies and Systems IKTS
- High-Speed Dynamics, Ernst-Mach-Institut, EMI
- Silicate Research ISC
- Solar Energy Systems ISE
- Systems and Innovation Research ISI
- Mechanics of Materials IWM
- Non-Destructive Testing IZFP

Permanent guests of the Group are the Institutes for:

- Industrial Mathematics ITWM
- Interfacial Engineering and Biotechnology IGB

Chairman of the Group

Prof. Dr.-Ing. Holger Hanselka

Fraunhofer Institute for Structural Durability and System Reliability, LBF

www.materials.fraunhofer.de

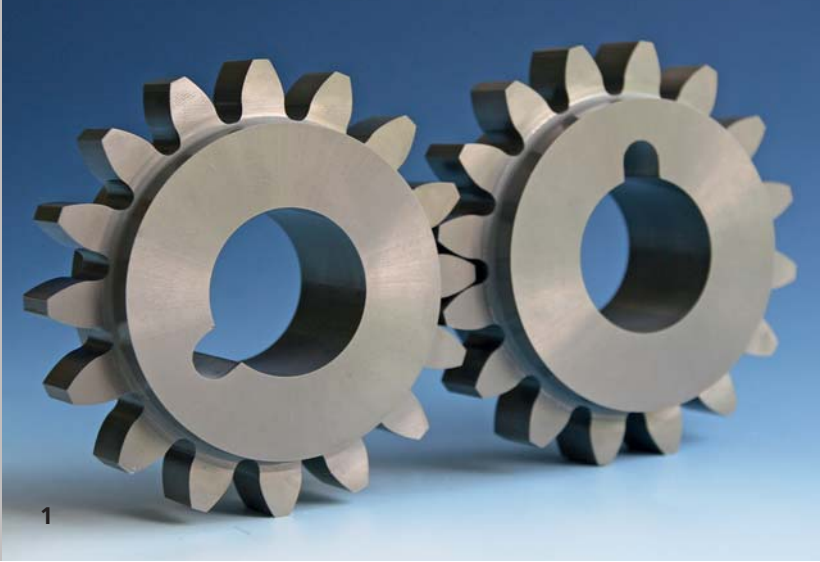

FRAUNHOFER ADVANCER ALLIANCE

Systems development with high-performance ceramics

The usage of high-performance ceramics allows for new applications in energy technology, mechanical and plant engineering, and medical technology. Well-known examples are combustion-chamber linings, roller bearings and implants. This innovative area has become an established field of expertise of the Fraunhofer-Gesellschaft.

Seven Fraunhofer Institutes (IKTS, IPK, IPT, ISC, IWM, IZFP and LBF) have joined together to form the Fraunhofer AdvanCer Alliance. The research activities of the Fraunhofer Alliance extend along the entire value-added chain from modeling and simulation through application-oriented materials development, production and machining of ceramic parts to component characterization, evaluation and non-destructive testing under application conditions. Current R&D activities focus on joining and integration methods.

Since 2005, the Fraunhofer AdvanCer Alliance has been offering training courses for technicians and engineers. The three parts being offered follow one after another, but can also be taken as single courses.

Fields of cooperation

- Materials development for structural ceramics, functional ceramics, fiber-reinforced ceramics, cermets, ceramic composites and adaptive composite materials
- Component design and development of functional prototypes

- Systems integration and verification of batch-production capabilities
- Development of powder, fiber and coating technologies
- Materials, component and process simulation
- Materials and component testing, proof-testing and non-destructive testing
- Defect analysis, failure analysis, quality management

Services offered

- Consulting and execution of feasibility studies
- Method and technology development
- Prototype development, technology transfer
- Completion of contract research, conceptualization and execution of alliance projects
- Workshops, seminars, training programs

Spokesperson of the Alliance

Dr. Michael Zins
Fraunhofer IKTS
michael.zins@ikts.fraunhofer.de

www.advancer.fraunhofer.de



CERAMICS MEETING POINT

Ceramics Meeting Point is an integral part of the public relations activities of Fraunhofer IKTS. The industry partners use the fast access to the research infrastructure of the Fraunhofer-Gesellschaft. The cooperation of Fraunhofer IKTS, TASK GmbH and its various members forms the basis for various industry projects, ranging from characterization of materials to the exclusive development project for large-scale production. The opportunity to see the latest research topics in one room and to get in contact with possible suppliers is advantageous for

the institute. The Fraunhofer AdvanCer Alliance comprising seven Fraunhofer Institutes also benefits from this infrastructure.

Together, the partners draw a bow from raw materials to systems and from prototypes to series components. TASK GmbH supports the Fraunhofer AdvanCer Alliance in conducting its workshops and training courses by providing the required practice-relevant and market information. Furthermore, the confidence in the evaluation of research approaches is strengthened. Thus, a project forum for small and medium-sized companies has developed, facilitating contacts to project initiators and research institutes. Hereby, the research volume for industrial associations is positively influenced.

Members of Ceramics Meeting Point

TASK
Technologie-Agentur
Struktur-Keramik



By visiting the Ceramics Meeting Point within the framework of numerous events taking place at Fraunhofer IKTS, once again more than 1500 visitors could inform about ceramic product innovations and manufacturers in 2012. Lots of the new exhibits focus on energy and environmental technology. Suppliers' interest in this sector is growing. The presentation of Ceramics Meeting Point at CERAMITEC, where 30 exhibitors presented their highlights on a total exhibition area of 325 m², was an outstanding success.

¹ "Day of Technical Ceramics" at CERAMITEC 2012.

NAMES, DATES, EVENTS

Granted patents 2012

Adam, H.; Franke, M.; Grunig, S.; Sikora, J.-R., Winterstein, G.

Device for monitoring of wear state of refractory lining of a melting tank, particularly a glass melting tank

DE 102 44 826 B4

Andrä, W.; Brand, M.; Lausch, H.; Werner, C.

Arrangement and method for recognizing and classifying preferably hidden objects in object and/or human traffic

US 8 188 733 B2

Böttge, D.; Adler, J.; Standke, G.

Cellular material for high-temperature applications and method for producing thereof

EP 2 373 418 B1

Endler, I.

Hard-material-coated bodies and method for their production

IN 251021

Endler, I.; Höhn, M.

Coated body of metal, hardmetal, cermet, ceramic or semiconductor and method for coating of these bodies

DE 10 2009 028 577 B4

Endler, I.; Höhn, M.

Bodies coated with a hard material and method for the production thereof

US 8 257 841 B2

MX 295 034, CN 101 952 480 B

Herrmann, M.; Matthey, B.

Method for producing composite components and composite

component produced with this method

DE 10 2011 109 573 B3

Kusnezoff, M.; Mosch, S.; Trofimenko, N.

Cathode electrolyte anode unit for solid oxide fuel cells and method for their production

EP 1 806 805 B1

Kusnezoff, M.; Reuber, S.

High-temperature fuel cell system

DE 10 2009 031 774 B4

Lenk, R.; Moriz, T.; Baumann, A.

Metal-ceramic composite with good adhesion and method for its production

EP 2 104 582 B1

Lenk, R.; Richter, H.-J.; Sitte, H.; Haußig, R.

Method and equipment for producing a structured broad-flat-component

DE 101 38 941 B4

Luthardt, R.G.; Rudolph, H.;

Johannes, M.; Voigtsberger, B.

Process for producing implants and components by direct shaping

CA 2 696 384 C

Moritz, T.; Richter, H.-J.; Baumann, A.; Lenk, R.; Walcher, H.; Maetzig, M.

Ceramic and/or powder-metal-lurgical composite shaped body and method for the production thereof

DE 10 2007 003 192 B4

Rödiger, T.; Füssel, A.

Method for producing a matching layer for ultrasonic transducer

DE 10 2009 021 680 B4

Sauchuk, V.; Otschik, P.; Eichler, K.; Kusnezoff, M.

Catalytically active component for thermal ionization detectors for the detection of halogen-containing compounds and process for producing an oxide-ceramic material for the component

JP 5 114 483

Schönecker, A.; Gebhardt, S.;

Seffner, L.

Method for producing a piezoelectric transducer

JP 4 896 331

Schmitt-Walter, S.; Seffner, L.;

Rödiger, T.; Gebhardt, S.;

Brückner, B.; Schönecker, A.

Pressure sensor

JP 5 040 008, US 8 297 133 B2

Schwarz, B.; Faßbauer, B.;

Friedrich, H.; Michaelis, A.;

Friedrich, E.

Method for the conversion of biomass from renewable raw materials in anaerobic fermenters

EP 2 183 374 B1

Waeschke, U.; Kusnezoff, M.;

Otschik, P.

Method and device for operating a fuel cell

EP 1 428 283 B1

Ziesche, S.; Kusnezoff, M.;

Henze, J.; Beckert, W.;

Kretzschmar, C.; Griebmann, H.

Arrangement and method for determining oxygen partial pressure in gas mixture

DE 10 2007 058 565 B4

Patent applications 2012

Ahlhelm, M.; Moritz, T.

Synthetic material for bone substitution and method for producing this material

Arnold, M.; Lausch, H.

Implant body

Eberstein, M.; Feller, C.

Reference electrode with porous ceramic membrane

Herrmann, M.; Standke, G.;

Himpel, G.; Höhn, S.; Kunze, S.

Refractory material for high-temperature use, method for its production and its application

Hubrich C.; Glanz, C.; Kolaric, I.;

Kinski, I.; Wätzig, K.

Method for producing composite powders with carbon nanotubes

Johannes, M.; Schneider, J.

Ceramic sintered bodies made of yttria stabilized zirconia and method for their production

Lausch, H.; Brand, M.; Arnold, M.

Stimulation box and method for in vitro stimulation of cells and tissues

Lausch, H.; Brand, M.; Arnold, M.;

Deshaes, José

Method, equipment and portable measuring device for detection of biological molecules in layers of a layer-system

Mammitzsch, L.; Petasch, U.;

Adler, J.; Wiegmann, A.; Cheng, L.

Particle filter

- Martin, H.-P.; Andersen, O.; Scholl, R.; Weißgärber, T.; Pacheco, V.
Thermoelectric module
- Richter, H.-J.; Scheithauer, U.; Haderk, K.; Refle, O.; Visotschnig, R.; Graf, C.
Method for producing a three-dimensional component by layer-by-layer generation
- Scheithauer, U.; Ahlhelm, M.; Moritz, T.
Method for production of components made of ceramic powder or metal powder
- Schilm, J.; Kusnezoff, M.; Rost A.
Composition for production of glass brazes for high temperatures and application thereof
- Scholl, R.; Slawik, T.
Sinter support
- Scholl, R.; Slawik, T.; Scheithauer, U.
Powder composition for production of metal or ceramic components, method for production of the powder and method for production of components
- Ziegler, T.; Schäfer, R.; Kraft, T.; Graf, C.; Visotschnig, R.; Richter, H.-J.; Haderk, K.
Dental prostheses
- **Books and periodical contributions**

- Bodur, C.T.; Thiele, M.; Herrmann, M.
Influence of microstructure on crack tip toughness of α -Sialon ceramics
- Journal of Ceramic Science and Technology 3(2012), No.3, p.105-110
- Borchardt, L.; Hoffmann, C.; Oschatz, M.; Mammitzsch, L.; Petasch, U.; Herrmann, M.; Kaskel, S.
Preparation and application of cellular and nanoporous carbides
- Chemical Society Reviews 41(2012), No.15, p.5053-5067
- Bräunig, R.E.; Fuchs, T.; Lenzner, K.; Luks, A.; Meyer, A.; Stein, J.; Potthoff, A.
NanOnLine – Online-Nanopartikelcharakterisierung für die Produktion
- Stuttgart: Fraunhofer Verlag, 2012 ISBN 978-3-8396-0363-5
- Czyperek, M.; Baumann, S.; Bouwmeester, H.J.; Meulenber, W.A.; Modigell, M.; Serra, J.M.; Shishatskiy, S.; Voigt, I.; Schulze-Küppers, F.
Membran gas separation membranes for energy-efficient processes
- Procedia Engineering 44(2012), p.1554-1556
- Duscher, S.; Herrmann, K.; Weyd, M.; Voigt, I.
Wirtschaftlicher Einsatz keramischer Membranen zur integrierten Prozesswasserbewirtschaftung – Fallbeispiele
- Chemie-Ingenieur-Technik 84(2012), No.7, p.1018-1025
- Eberstein, M.; Falk-Windisch, H.; Peschel, M.; Schilm, J.; Seuthe, T.; Wenzel, M.; Kretzschmar, C.; Partsch, U.
Sintering and contact formation of glass containing silver pastes
- Energy Procedia 27(2012), p.522-530
- Eckhard, S.; Fries, M.; Lenzner, K.; Nebelung, M.
Variation der Produkteigenschaften sprühgetrockneter SiO₂-Granulate aus nanoskaligen Primärpartikeln
- Chemie-Ingenieur-Technik 84(2012), No.3, p.335-342
- Endler, I.; Höhn, M.; Schmidt, J.; Scholz, S.; Herrmann, M.; Knaut, M.
Ternary and quaternary TiSiN and TiSiCN nanocomposite coatings obtained by Chemical Vapor Deposition
- Surface and Coatings Technology (2012), doi: 10.1016/j.surfcoat.2012.10.067, online first
- Fausser, G.; Schneider, M.
Comparison between state of charge determination methods for Li-ion batteries based on the measurement of impedance, voltage and coulomb counting
- Kanoun, O.(Hrsg.); Lecture Notes on Impedance Spectroscopy 3(2012), p.85-90
- Feng, B.; Martin, H.-P.; Hempel-Weber, R.; Michaelis, A.
Preparation and thermoelectric properties of B₄C-Si-B composites
- AIP Conference Proceedings 1449(2012), p.315-318
- Freund, S.; Gaal, A.
AdvanCer Newsletter.
- Issues 2012, No. 1, 2, 3
Dresden: Fraunhofer-Allianz AdvanCer, 2012
- Fries, M.; Potthoff, A.; Eisele, U.
Activity report of the working group properties of synthetic processing of ceramic raw materials. Editorial
- International Journal of Materials Research 103(2012), No.4, p.523-524
- Frind, R.; Borchardt, L.; Kockrick, E.; Mammitzsch, L.; Petasch, U.; Herrmann, M.; Kaskel, S.
Complete and partial oxidation of methane on ceria/platinum silicon carbide nanocomposites
- Catalysis Science & Technology 2(2012), No.1, p.139-146
- Grund, M.; Schulz, M.; Sydow, U.
Entwicklung von Festkörperelektrolyten auf Basis von B⁺ Aluminiumoxidkeramiken für Na-Hochtemperaturbatterien
- Werkstofftechnik aktuell 7(2012), p.9-12
- Heddrich, M.P.
Thermodynamische Analyse von SOFC-Systemkonzepten und experimentelle Validierung
- Michaelis, A.(Hrsg.); IKTS Stuttgart: Fraunhofer Verlag, 2012 (Kompetenzen in Keramik. Schriftenreihe, 14)
Zugl.: Clausthal, TU, Diss., 2012 ISBN 978-3-8396-0466-3
- Herrmann, M.; Höhn, S.; Bales, A.
Kinetics of rare earth incorporation and its role in densification and microstructure formation of α -Sialon
- Journal of the European Ceramic Society 32(2012), No.7, p.1313-1319
- Herrmann, M.; Matthey, B.; Höhn, S.; Kinski, I.; Rafaja, D.; Michaelis, A.
Diamond-ceramics composites – New materials for a wide range of challenging applications
- Journal of the European Ceramic Society 32(2012), No.9, p.1915-1923
- Herrmann, M.; Sigalas, I.;

- Thiele, M.; Kleebe, H.-J.; Michaelis, A.; Müller, M.M. **Boron suboxide ultrahard materials** International Journal of Refractory Metals and Hard Materials (2012), doi: 10.1016/j.ijrmhm.2012.02.009, online first
- Jobst, K.; Lincke, M. **Methoden zur Ermittlung der physikalischen Parameter: Viskosität: Modifizierung von Messsystemen für den Einsatz an faserigen Suspensionen** Liebetrau, J. (Hrsg.) u.a.; DBFZ Deutsches Biomasseforschungszentrum gemeinnützige GmbH Messmethodensammlung Biogas: Methoden zur Bestimmung von analytischen und prozessbeschreibenden Parametern im Biogasbereich. (Schriftenreihe des BMU-Förderprogramms "Energetische Biomassenutzung" Band 7) Leipzig: DBFZ, 2012, p.84-94
- Johannes, M.; Schneider, J. **Processing of nanostructured zirconia composite ceramics with high aging resistance** Journal of Ceramic Science and Technology 3(2012), No.3, p.151-158
- Johnson, O.T.; Sigalas, I.; Herrmann, M.; Kleebe, H.J. **Densification and properties of superhard B₂O₃ materials with cobalt additions** Journal of the European Ceramic Society 32(2012), No.10, p.2573-2579
- Kavurucu Schubert, S.; Kusnezoff, M.; Michaelis, A.; Bredikhin, S.I. **Comparison of the performances of single solid oxide fuel cell stacks with Ni/8YSZ and Ni/10CGO anodes with H₂S containing fuel** Journal of Power Sources 217(2012), p.364-372
- Kavurucu Schubert, S. **Effects of hydrogen sulfide in fuel gas on SOFC stack performance with nickel containing anodes** Michaelis, A.(Hrsg.); IKTS Stuttgart: Fraunhofer Verlag, 2012 (Kompetenzen in Keramik. Schriftenreihe 13) Zugl.: Dresden, TU, Diss., 2012 ISBN 978-3-8396-0462-5
- Khavrus, V.O.; Weiser, M.; Fritsch, M.; Ummethala, R.; Salvaggio, M.G.; Schneider, M.; Kusnezoff, M.; Leonhardt, A. **Application of carbon nanotubes directly grown on aluminum foils as electric double layer capacitor electrodes** Chemical Vapor Deposition: CVD 18(2012), No.1-3, p.53-60
- Kirchsen, R.; Töpfer, J. **Nonstoichiometry, point defects and magnetic properties in Sr(2)FeMoO(6-δ) double perovskites** Journal of Solid State Chemistry 185(2012), p.76-81
- Kühnel, D.; Scheffler, K.; Wellner, P.; Meißner, T.; Potthoff, A.; Busch, W.; Springer, A.; Schirmer, K. **Comparative evaluation of particle properties, formation of reactive oxygen species and genotoxic potential of tungsten carbide based nanoparticles in vitro** Journal of Hazardous Materials 227-228(2012), p.418-426
- Lackner, G.; Endler, I.; Meissner, F.; Scholz, S.; Mayer-Uhma, T.; Liebschner, R.; Bezugly, V.; Meiss, J.; Mkandawire, M.; Boucher, R.; Michaelis, A.; Lupascu, D.C. **Dyes in vertically aligned carbon nanotube arrays for solar cell applications** Materials Research Society Symposium Proceedings 1390(2012), p.155-160
- Lackner, G.; Mayer-Uhma, T.; Endler, I.; Boucher, R.; Meißner, F.; Scholz, S.; Krug, M.; Bezugly, V.; Mkandawire, M.; Majumder, A.; Kovalenko, D.A.; Conze, S.; Hildebrandt, S.; Michaelis, A.; Lupascu, D.C. **Dyes in carbon nanotube arrays** Journal of Materials Science and Engineering. B 2(2012), No.6, p.334-346
- Lausch, H. **Strom ohne Kabel übertragen** Polyscope (2012), No.16, p.48
- Lehmann, T.; Friedrich, E. **Lignozellulosehaltige Substrate – (k)ein Problem für Biogasanlagen?** Landtechnik 67(2012), No.2, p.114-117
- Lehmann, T.; Friedrich, E. **Stroh statt Feldfrüchte** Landtechnik 67(2012), No.5, p.358-360
- Liang, F.; Jiang, H.; Luo, H.; Kriegel, R.; Caro, J. **High-purity oxygen production by a dead-end Ba_{0.5}Sr_{0.5}Co_{0.8}Fe_{0.2}O_{3-δ} tube membrane** Catalysis Today 193(2012), No.1, p.95-100
- Lincke, M.; Schwarz, B. **Methoden zur Ermittlung der biologischen Parameter: Gasertragstest (Batch)** Liebetrau, J. (Hrsg.) u.a.; DBFZ Deutsches Biomasseforschungszentrum gemeinnützige GmbH Messmethodensammlung Biogas: Methoden zur Bestimmung von analytischen und prozessbeschreibenden Parametern im Biogasbereich. (Schriftenreihe des BMU-Förderprogramms "Energetische Biomassenutzung" Band 7) Leipzig: DBFZ, 2012, p.123-127
- Lincke, M.; Schwarz, B. **Methoden zur Ermittlung der biologischen Parameter: Kontinuierliche Vergärungsversuche** Liebetrau, J. (Hrsg.) u.a.; DBFZ Deutsches Biomasseforschungszentrum gemeinnützige GmbH Messmethodensammlung Biogas: Methoden zur Bestimmung von analytischen und prozessbeschreibenden Parametern im Biogasbereich. (Schriftenreihe des BMU-Förderprogramms "Energetische Biomassenutzung" Band 7) Leipzig: DBFZ, 2012, p.128-131
- Lincke, M.; Jobst, K. **Methoden zur Ermittlung der physikalischen Parameter: Partikelgrößenverteilung** Liebetrau, J. (Hrsg.) u.a.; DBFZ Deutsches Biomasseforschungszentrum gemeinnützige GmbH Messmethodensammlung Biogas: Methoden zur Bestimmung von analytischen und prozessbeschreibenden Parametern im Biogasbereich. (Schriftenreihe des BMU-Förderprogramms "Energetische Biomassenutzung" Band 7) Leipzig: DBFZ, 2012, p.69-72

- Littringer, E.M.; Mescher, A.; Eckhard, S.; Schröttner, H.; Langes, C.; Fries, M.; Griesser, U.; Walzel, P.; Urbanetz, N.A.
Spray drying of mannitol as a drug carrier – The impact of process parameters on product properties
Drying Technology 30(2012), No.1, p.114-124
- Lomtscher, A.
Methoden zur Ermittlung der physikalischen Parameter: Strömungsuntersuchung: Einsatz der Prozess-Tomographien
Liebetrau, J. (Hrsg.) u.a.; DBFZ Deutsches Biomasseforschungszentrum gemeinnützige GmbH
Messmethodensammlung Biogas: Methoden zur Bestimmung von analytischen und prozessbeschreibenden Parametern im Biogasbereich. (Schriftenreihe des BMU-Förderprogramms "Energetische Biomassennutzung" Band 7)
Leipzig: DBFZ, 2012, p.101-105
- Lubkowski, G.; Kuhnhen, J.; Suhrke, M.; Weiland, U.; Endler, I.; Meißner, F.; Richter, S.
Gamma radiation effects in vertically aligned carbon nanotubes
IEEE Transactions on Nuclear Science 59(2012), No.4, Pt.1, p.792-796
- MacHaka, R.; Mwakikunga, B.W.; Manikandan, E.; Derry, T.E.; Sigalas, I.; Herrmann, M.
Mechanical and structural properties of fluorine-ion-implanted boron suboxide
Advances in Materials Science and Engineering. Online Journal(2012), Art. 792973, p.11, doi:10.1155/2012/792973
- Meißner, T.
Methoden der Nanopartikelcharakterisierung zur Optimierung toxikologischer Studien
Michaelis, A. (Hrsg.); IKTS Stuttgart: Fraunhofer Verlag, 2012 (Kompetenzen in Keramik. Schriftenreihe 12)
Zugl.: Dresden, TU, Diss., 2012 ISBN 978-3-8396-0412-0
- Michaelis, A.; Schneider, M. (Hrsg.)
Symposium "Anodisieren – Vom Korrosionsschutz bis zur Nanotechnologie"
Tagungsband; IKTS Stuttgart: Fraunhofer Verlag, 2012 ISBN 978-3-8396-0481-6
- Moraes, I.R. de; Scholz, S.; Lüssem, B.; Leo, K.
Chemical degradation processes of highly stable red phosphorescent organic light emitting diodes
Organic Electronics 13(2012), No.10, p.1900-1907
- Moritz, T.; Mannschatz, A.; Müller-Köhn, A.; Kucera, A.
Current opportunities and challenges for CIM technology
Ceramic Forum International: CFI. Berichte der Deutschen Keramischen Gesellschaft 89(2012), No.10, p.E21-E25
- Naidoo, M.; Räthel, J.; Sigalas, I.; Herrmann, M.
Preparation of (Ti,Ta)-(C,N) by mechanical alloying
International Journal of Refractory Metals and Hard Materials 35(2012), p.178-184
- Ortmann, C.; Oberbach, T.; Richter, H.; Puhlfürß, P.
Preparation and characterization of ZTA bioceramics with and without gradient in composition
Journal of the European Ceramic Society 32(2012), No.4, p.777-785
- Pawlowski, B.; Schabbel, D.; Barth, S.; Fischer, M.; Bartsch, H.; Hoffmann, M.; Müller, J.
SiCer – ein innovativer Substratwerkstoff für MEMS
Keramische Zeitschrift 64(2012), Beilage Handbuch der Keramik (2012), Gruppe II K 4.3, Folge 461
- Pavlyuchkov, D.; Fabrichnaya, O.; Herrmann, M.; Seifert, H.J.
Thermodynamic assessments of the Al₂O₃-Al₄C₃-AlN and Al₄C₃-AlN-SiC systems
Journal of Phase Equilibria and Diffusion 33(2012), No.5, p.357-368
- Pensold, S.; Höhn, S.
Ion beam etching: New technique for high-resolution structural analyses of coatings
IPW (2012), No.4-5, p.44-47
- Pötschke, J.; Richter, V.; Holke, R.
Influence and effectivity of VC and Cr₃C₂ grain growth inhibitors on sintering of binderless tungsten carbide
International Journal of Refractory Metals and Hard Materials 31(2012), p.218-223
- Pönicke, A.; Schilm, J.; Triebert, A.; Sempf, K.; Gestrich, T.; Martin, H.-P.; Böhm, G.; Schnee, D.
Aktivlötten von Kupfer mit Aluminiumnitrid- und Siliziumnitridkeramik, Teil 1
Keramische Zeitschrift 64(2012), Beilage Handbuch der Keramik (2012), Gruppe II K 4.4, Folge 462
- Rabbow, T.J.; Junker, N.; Kretzschmar, C.; Schneider, M.; Michaelis, A.
Electrochemically induced degradation of screen-printed gold thick films
Journal of Ceramic Science and Technology 3(2012), No.4, p.199-210
- Reichel, U.
Mikrostruktur und Eigenschaften von mit Nanometallfluorid dotierter hochreiner Aluminiumoxid-Keramik
Kriegesmann, J. (Hrsg.): Technische Keramische Werkstoffe, Loseblattausgabe, Ellerau: HvB-Verlag, Kapitel 4.2.1.3
- Reinecke, S.; Deutschmann, A.; Jobst, K.; Kryk, H.; Friedrich, E.; Hampel, U.
Flow following sensor particles – Validation and macro-mixing analysis in a stirred fermentation vessel with a highly viscous substrate
Biochemical Engineering Journal 69(2012), p.159-171
- Rödel, C.; Müller, M.; Glorius, M.; Potthof, A.; Michaelis, A.
Effect of varied powder processing routes on the stabilizing performance and coordination type of polyacrylate in alumina suspensions
Journal of the European Ceramic Society 32(2012), No.2, p.363-370
- Rödel, C.; Wehner, F.; Meyer, A.; Meißner, T.; Potthoff, A.; Michaelis, A.
Influence of polyvinyl alcohol/zirconium polycation interactions on the properties of aqueous alumina suspensions
Journal of Ceramic Science and Technology 3(2012), No.3, p.141-150

- Rösler, G.; Rösler, J.; Schirmer, P.; Häusler, A.; Fischer, G.
Material- und Energieeffizienz in der Porzellanindustrie – Grundlage für die Wettbewerbsfähigkeit der Branche
Chemie-Ingenieur-Technik 84(2012), No.10, p.1812-1818
- Rost, A.; Schilm, J.; Kusnezoff, M.; Michaelis, A.
Degradation of sealing glasses for SOFC under electrical load and dual atmosphere
Journal of Ceramic Science and Technology 3(2012), No.2, p.69-80
- Scheithauer, U.; Slawik, T.
Spiralwickeln keramischer und pulvermetallurgischer Grünfolien
Keramische Zeitschrift 64(2012), No.1, p.35-39
- Schilm, J.; Rost, A.; Pönicke, A.; Kusnezoff, M.; Michaelis, A.
Ceramic integration technologies for solid oxide fuel cells
International Journal of Applied Ceramic Technology 9(2012), No.4, p.688-699
- Schmidt, F.; Klemm, H.; Schönfeld, K.; Gerds, A.; Hungerbach, W.; Kaskel, S.; Lookeren Campagne, C.J. van
Novel composite spherical granulates with catalytic outer layer and improved conversion efficiency and selectivity
Chemical Engineering and Technology 35(2012), No.4, p.769-775
- Schneider, M.; Weiser, M.; Dörfler, S.; Althues, H.; Kaskel, S.; Michaelis, A.
Electrodeposition of copper on aligned multi-walled carbon nanotubes
Surface Engineering 28(2012), No.6, p.435-441
- Schneider, M.; Schroth, S.; Schubert, N.; Michaelis, A.
In-situ investigation of the surface-topography during anodic dissolution of copper under near-ECM conditions
Materials and Corrosion 63 (2012), No.2, p.96-104
- Schneider, M.; Schroth, S.; Richter, S.; Höhn, S.; Schubert, N.; Michaelis, A.
In-situ investigation of the interplay between microstructure and anodic copper dissolution under near-ECM conditions. Pt.2: The transpassive state
Electrochimica Acta 70(2012), p.76-83
- Schneider, M.; Langklotz, U.; Labus, M.; Arnold, B.; Michaelis, A.
Investigation of corrosion products formed on C35-ALMgSi0,5 friction welds during natural weathering in marine climate
Corrosion Engineering, Science and Technology: CEST 47(2012), No.4, p.312-319
- Schneider, M.; Langklotz, U.; Sempf, K.
Korrosionsschaden an einem Rennradlenker aus AA 7075
Praktische Metallographie 49(2012), No.8, p.511-530
- Schubert, N.; Schneider, M.; Michaelis, A.
Influence of electrolyte viscosity on the surface quality during ECM of cobalt in alkaline electrolytes
Galvanotechnik 103(2012), No.8, p.1682-1688
- Schubert, R.; Tupaika, F.; Kuhn, J.
Funktionell modifizierte anorganisch-organische Composite-Werkstoffe
Kriegesmann, J. (Hrsg.): Technische Keramische Werkstoffe, Loseblattausgabe, Ellerau: HvB-Verlag, Kapitel 4.8.2.0
- Schulz, M.; Pippardt, U.; Kiesel, L.; Ritter, K.; Kriegel, R.
Oxygen permeation of various archetypes of oxygen membranes based on BSCF
AIChE Journal 58(2012), No.10, p.3195-3202
- Schuster, C.; Klimke, J.; Schwingenschlögl, U.
High energy transmission of Al₂O₃ doped with light transition metals
The Journal of Chemical Physics 136(2012), No.4, Art. 044522, p.4
- Sempf, K.; Herrmann, M.; Sydow, U.
Neue Möglichkeiten der Gefügedarstellung von SiC-Werkstoffen
Praktische Metallographie 49(2012), No.2, p.64-74
- Seuthe, T.; Höfner, M.; Reinhardt, F.; Tsai, W.J.; Bonse, J.; Eberstein, M.; Eichler, H.J.; Grehn, M.
Femtosecond laser-induced modification of potassium-magnesium silicate glasses: An analysis of structural changes by near edge x-ray absorption spectroscopy
Applied Physics Letters 100(2012), No.22, Art. 224101, p.3
- Slawik, T.; Handke, T.; Scholl, R.; Scheithauer, U.; Zelm, R.; Moritz, T.; Großmann, H.; Michaelis, A.; Baumann, A.
Spiralwickeltechnik für mehrlagige keramische Hülsen
Wochenblatt für Papierfabrikation 140(2012), No.5, p.330-333
- Thiele, M.; Herrmann, M.; Räthel, J.; Kleebe, H.-J.; Mueller, M.M.; Gestrich, T.; Michaelis, A.
Preparation and properties of B₆O/TiB₂-composites
Journal of the European Ceramic Society 32(2012), No.8, p.1821-1835
- Toma, F.-L.; Berger, L.-M.; Scheitz, S.; Langner, S.; Rödel, C.; Potthoff, A.; Sauchuk, V.; Kusnezoff, M.
Comparison of the microstructural characteristics and electrical properties of thermally sprayed Al₂O₃ coatings from aqueous suspensions and feedstock powders
Journal of Thermal Spray Technology 21(2012), No.3-4, p.480-488
- Wall, Y.; Braun, G.; Kaltenborn, N.; Voigt, I.; Brunner, G.
Separation of CO₂/N₂ by means of a carbon membrane
Chemical Engineering and Technology 35(2012), No.3, p.508-512
- Weyd, M.; Richter, H.; Troeber, O.; Hoyer, T.; Voigt, I.
Bio alcohol concentration by pervaporation with organophilic zeolite membranes –Influence of protective coatings on fouling tendency
Procedia Engineering 44(2012), p.549-552
- Zgalat-Lozynskyy, O.; Herrmann, M.; Ragulya, A.; Andrzejczuk, M.; Polotai, A.
Structure and mechanical properties of spark plasma sintered

TiN-based nanocomposites

Archives of Metallurgy and Materials 57(2012), No.3, p.853-858

Ziesche, S.; Partsch, U.

Sensors based on ceramic multilayer technology

Ceramic Forum International: CFI. Berichte der Deutschen Keramischen Gesellschaft 89(2012), No.4, p.E43-E45

Zschippang, E.; Klemm, H.;

Herrmann, M.; Sempf, K.; Guth, U.; Michaelis, A.

Electrical resistivity of silicon nitride-silicon carbide based ternary composites

Journal of the European Ceramic Society 32(2012), No.1, p.157-165

Presentations and Posters

Adler, J.; Böttge, D.; Standke, G.;

Krech, T.; Krippendorf, R.; Scholz, P.

Catalytically functionalized ceramic foams for exhaust gas treatment

Cellular Materials – CELLMAT 2012, Dresden (7.-9.11.2012), Presentation

Adler, J.

Ceramic diesel particulate filters – Status and trends

10th International Symposium on Ceramic Materials and Components for Energy and Environmental Applications – CMCEE 2012, Dresden (20.-23.5.2012), Presentation

Ahlhelm, M.; Moritz, T.; Michaelis, A.

Freeze foaming – A direct foaming technique achieving cellular structures for versatile applications

4th International Congress on Ceramics – ICC4, Chicago (15.-19.7.2012), Presentation, Poster

Ahlhelm, M.; Gorjup, E.; von Briesen, H.; Moritz, T.

Freeze-foaming: A promising new approach to manufacture ceramic cellular structures enabling the ingrowth and differentiation of human mesenchymal stem cells

Bio-inspired Materials – International School and Conference on Biological Materials Science, Potsdam (20.-23.3.2012), Presentation, Poster

Ahlhelm, M.; Gorjup, E.; Briesen, H. von; Moritz, T.; Michaelis, A.

Freeze-foaming: A promising new approach to manufacture strength enhanced bioactive materials

Jahrestagung der Deutschen Gesellschaft für Biomaterialien, Hamburg (1.-3.11.2012), Presentation

Ahlhelm, M.; Müller-Köhn, A.;

Mannschatz, A.; Moritz, T.

PIM-Simulation und Verifizierung fasergefüllter keramischer Massen

Moldex3D-Anwendertreffen 2012, Stuttgart (5./6.3.2012), Presentation

Ahlhelm, M.; Mannschatz, A.;

Müller, A.; Moritz, T.; Michaelis, A.

Powder injection moulding of translucent ceramic parts

4th International Congress on Ceramics – ICC4, Chicago (15.-19.7.2012), Presentation, Poster

Ahlhelm, M.; Richter, H.-J.; Haderk, K.

Selective laser sintering as additive manufacturing method for manufacturing ceramic components

2nd International Symposium on Materials Processing Science with Lasers as Energy Sources, Clausthal (24./25.4.2012), Presentation

Ahlhelm, M.; Gorjup, E.;

Briesen, H. von; Moritz, T.

Strength enhanced bioactive hydroxyapatite freeze-foams

Bio-Inspired Materials, Potsdam (20.-23.3.2012), Poster

Barth, S.; Bartsch, H.; Töpfer, J.

Functional materials for integration of passive components into LTCC multilayer package

10th International Symposium on Ceramic Materials and Components for Energy and Environmental Applications – CMCEE 2012, Dresden (20.-23.5.2012), Presentation

Baltz, T.; Haselier, C.; Hesse, S.; Meißner, F.; Endler, I.; Walter, P.; Thumann, G.

Effect of multi-walled carbon nanotubes on R28 retinal precursor cell survival

ARVO Annual Meeting 2012, Fort Lauderdale (6.-10.5.2012), Poster

Barth, S.; Kastner, F.; Röbber, M.; Wentorp, R.; Töpfer, J.;

Low firing functional materials for application in power electronics

8th International Conference and Exhibition on Ceramic Interconnect and Ceramic Microsystems Technologies – CICMT 2012, IMAPS/ACerS, Erfurt (16.-19.4.2012), p.664-669/THA46, Presentation

Bartsch, H.; Barth, S.; Müller, J.

Embedded ceramic capacitors in LTCC

8th International Conference and Exhibition on Ceramic Interconnect and Ceramic Microsystems Technologies – CICMT 2012, IMAPS/ACerS, Erfurt (16.-19.4.2012), p.464-468/WP13, Presentation

Beckert, W.; Taubenreuther, M.

Cell winding – A multiphysics simulation

9th Symposium Hybrid and Electric Vehicles, Braunschweig (14.2.2012), p.132-138, Presentation

Beckert, W.; Frölich, T.; Freytag, C.; Wolter, M.

Hybrid thermal-electric battery cell model

NAFEMS European Conference: Multiphysics Simulation 2012, Frankfurt (16.10.12), Presentation

Belda, C.; Dietzen, E.;

Kusnezoff, M.; Trofimenko, N.

Diffusion barrier layer materials for metal-supported SOFC

10th International Symposium on Ceramic Materials and Components for Energy and Environmental Applications – CMCEE 2012, Dresden (20.-23.5.2012), Poster

Belitz, R.; Jahn, M.; Koszyk, S.; Michaelis, A.

Reaktionstechnische Untersuchungen zur CO-Hochtemperaturkatalyse

45. Jahrestreffen Deutscher Katalytiker, Weimar (14.-16.3.2012), Poster

Bierlich, S.; Töpfer, J.; Barth, S.; Pawlowski, B.; Müller, J.;

Cofiring behavior of multilayer inductors based on substituted Y- and M-type hexagonal ferrites

8th International Conference and Exhibition on Ceramic Interconnect and Ceramic Microsystems Technologies – CICMT 2012, IMAPS/ACerS, Erfurt (16.-19.4.2012), p.659-663/THA45, Presentation

Böhme, S.; Stärk, H.-J.; Meißner, T.; Kühnel, D.; Busch, W.

- Internalization of aluminium oxide nanoparticles into human cells: Impact of particle size on the quantitative uptake**
Nanosafe 2012, Grenoble (13.-15.11.2012), Poster
- Böhning, D.; Beckmann, M.; Kriegel, R.; Richter, J.; Müller, M.; Ma, M.; Glühning, J.; Ruhe, N.
- Kombiniertes Katalysator- und Sauerstoffträgersystem zur Aufbereitung teerhaltiger Brenngase aus der Biomassevergasung via partielle Oxidation**
DGMK-Fachbereichstagung Konversion von Biomassen "Velen X", Rotenburg a. d. Fulda (19.-21.3.2012), Presentation
- Bremerstein, T.
- Einfluss von Suspensionsparametern auf die Rheologie**
VDI Working group Granulometrie, Dresden (18.10.2012), Presentation
- Bretthauer, C.; Fauser, G.; Leiva, D.; Fritsch, M.; Barth, S.; Schneider, M.
- Materials, processing and quality control in Li-ion battery development**
10th International Symposium on Ceramic Materials and Components for Energy and Environmental Applications – CMCEE 2012, Dresden (20.-23.5.2012), Presentation
- Conze, S.; Grin, Y.; Kinski, I.; Michaelis, A.; Schnelle, W.; Veremchuk, I.
- Magnéli phase Ti_4O_7 – obtained from an organo-metallic precursor – for thermoelectric application**
10th International Symposium on Ceramic Materials and Components for Energy and Environmental Applications – CMCEE 2012, Dresden (20.-23.5.2012), Presentation
- Conze, S.; Veremchuk, I.; Schnelle, W.; Michaelis, A.; Grin, Y.; Kinski, I.
- TiO_2 as filler in a precursor-derived TiO_x matrix as thermoelectric material with an enhanced ZT value**
31st International & 10th European Conference on Thermoelectrics – ICT/ECT 2012, Aalborg (9.-12.7.2012), Poster
- Czyperek, M.; Baumann, S.; Bouwmeester, H. J.; Meulenberg, W. A.; Modigell, M.; Serra, J. M.; Shishatskiy, S.; Voigt, I.; Schulze-Küppers, F.
- Membrane gas separation processes**
Euromembrane 2012, London (23.-27.9.2012), Poster
- Dannowski, M.; Beckert, W.; Michaelis, A.
- Modeling of thermoelectric applications for waste heat usage**
10th International Symposium on Ceramic Materials and Components for Energy and Environmental Applications – CMCEE 2012, Dresden (20.-23.5.2012), Presentation
- De la Vega, F.; Mosch, S.; Schilm, J.; Partsch, U.
- Low contact resistance ink-jet solar metallization inks for a plug and play system**
27th European Photovoltaic Solar Energy Conference and Exhibition – EU PVSEC, Frankfurt (24.-28.9.2012), Presentation
- Decker, M.; Vonau, W.; Rabbow, T.; Schneider, M.; Eichler, R.; Konat-Stepowicz, J.; Bause, S.
- Untersuchungen zur hochempfindlichen elektrochemischen H_2O_2 -Bestimmung im Atemkon-**
- densat**
4. Dresdner Medizintechnik Symposium, Dresden (3.-5.12.2012), Presentation
- Deutschmann, A.; Vollmann, M.; Saft, F.; Faßauer, B.
- Effluent inline disinfection by means of two different types of nano-modified diamond electrodes at a sewage treatment plant**
6th IWA Conference on Oxidation Technologies for Water and Wastewater Treatment – AOP6, Goslar (7.-9.5.2012), Poster
- Deutschmann, A.; Jobst, K.; Friedrich, E.
- Prozess-Tomographie – Die Möglichkeit der praxisnahen Bewertung und Optimierung von Mischprozessen**
5. Biogas-Innovationskongress 2012, Osnabrück (10./11.5.2012), Presentation
- Dohndorf, H.; Richter, J.; Fischer, G.; Klotsche, U.; Werschy, M.; Prehn, V.
- Katalytische Reinigung von Abgasen aus Feuerfestbrennstoff-Feuerstätten**
Thüringer Werkstofftag, Weimar (14.3.2012), Poster
- Eberstein, M.
- Gläser als Schlüsselkomponenten für hochperformante Steuerelektronik im Automobil**
6. CTI Konferenz Glas im Automobil, Stuttgart (23./24.4.2012), Presentation
- Eberstein, M.; Schilm, J.; Kretzschmar, C.; Partsch, U.
- Kinetic aspects of the contact formation by glass containing silver pastes**
27th European Photovoltaic Solar Energy Conference and Exhibition – EU PVSEC, Frankfurt (24.9.2012), p.840-844, Presentation
- Eberstein, M.; Schilm, J.; Partsch, U.; Waltinger, A.
- Kinetic phenomena during the solar cell contact formation of glass containing silver pastes**
11th ESG Conference and 86. DGG-Jahrestagung, Maastricht (4.-7.6.2012), Presentation
- Eberstein, M.
- Kontrollierte Abscheidung funktioneller Schichten über Druckverfahren**
Werkstoffwissenschaftliches Kolloquium der FA Universität Erlangen, Erlangen (24.1.2012), Presentation
- Eberstein, M.; Schilm, J.; Partsch, U.
- Kurzzeitsintern glashaltiger Silberpasten für die Solarzellenkontaktierung**
Fachausschuss I der DGG "Chemie und Physik des Glases", Clausthal (10.10.2012), Presentation
- Eberstein, M.; Feller, C.; Seuthe, T.; Ihle, M.; Ziesche, S.; Gora, F.
- Silver processing in thick-film technology for power electronics**
8th International Conference and Exhibition on Ceramic Interconnect and Ceramic Microsystems Technologies – CICMT 2012, IMAPS/ACerS, Erfurt (16.-19.4.2012), p.18-24/TA3, Presentation
- Eckhard, S.; Fries, M.; Höhn, S.; Rödel, C.; Nebelung, M.
- Einfluss der Suspensionseigenschaften auf die resultierenden Granulateigenschaften bei der Sprühtrocknung keramischer Suspensionen**
10. Workshop über Sprays, Techniken der Fluidzerstäubung und Un-

tersuchungen von Sprühvorgängen – SPRAY 2012, Berlin (21./22.5.2012), Presentation	Faßauer, B.; Deutschmann, A.; Jobst, K.; Lomtscher, A.; Friedrich, E.	Fischer, G.	Hochleistungskeramik Teil I: Werkstoffe, Verfahren, Dresden (14./15.3.2012), Presentation
Eckhard, S.; Fries, M.; Höhn, S.; Rödel, C.	Verbesserung der Durchmischung in Biogasreaktoren	Cordierite for thermochemically resistant particle filter	Fries, M.
Influence of varied suspension properties on properties of spray-dried granules	Energetische Biomassennutzung – Neue Technologien und Konzepte für die Bioenergie der Zukunft, Berlin (5.-6.11.2012), Presentation	10th International Symposium on Ceramic Materials and Components for Energy and Environmental Applications – CMCEE 2012, Dresden (20.-23.5.2012), Presentation	Thermische Granulationsverfahren
12th International Conference on Liquid Atomization and Spray Systems – ICLASS 2012, Heidelberg (2.-6.9.2012), Presentation	Fausser, G.; Wolter, M.; Clauß, M.; Lorenz, P.; Tittel, D.; Taubenreuther, M.	Fischer, G.; Lauenroth, S.; Richter, H.	17. DKG-Fortbildungsseminar – Technologische Grundlagen der Granulierung und Granulatverarbeitung, Dresden (18./19.4.2012), Presentation
Eckhard, S.; Fries, M.; Nebelung, M.; Heinrich, S.; Antonyuk, S.	Concept for enhanced failure detection in traction batteries	Zeolithe für die Wärmespeicherung	Füssel, A.; Adler, J.; Michaelis, A.
Influence of the internal granule structure on mechanical properties	Advanced Automotive Battery Conference – AABC Europe 2012, Mainz (18.-22.6.2012), Presentation, Poster	17. Fachausschusssitzung des DKG-Fachausschusses 6 "Werkstoffanwendung", Meißen (18.9.2012), Presentation	Cellular ceramic material for application in porous burner technology
7th International Conference for Conveying and Handling of Particulate Solids, Friedrichshafen (10.-13.9.2012), Poster	Feller, C.; Furche, S.; Eberstein, M.	Fischer, M.; Mache, T.; Pawlowski, B.; Schabbel, D.; Müller, J.	10th International Symposium on Ceramic Materials and Components for Energy and Environmental Applications – CMCEE 2012, Dresden (20.-23.5.2012), Presentation
Endler, I.	Development and characterization of glass matrix composites as porous coating film of a solid-state reference electrode	SiCer – a substrate to combine ceramic and silicon based micro systems	Ganzer, G.; Schöne, J.; Beckert, W.
Neue Entwicklungen bei CVD-Verschleißschutzschichten für Hartmetallwerkzeuge	8th International Conference and Exhibition on Ceramic Interconnect and Ceramic Microsystems Technologies – CICMT 2012, IMAPS/ACerS, Erfurt (16.-19.4.2012), p.200-207/TP46	8th International Conference and Exhibition on Ceramic Interconnect and Ceramic Microsystems Technologies – CICMT 2012 – IMAPS/ACerS, Erfurt (16.-19.4.2012), Presentation	Modeling support for solid oxide fuel cell-component development
31. Hagener Symposium Pulvermetallurgie, Hagen (29./30.11.2012), Presentation	Feng, B.; Martin, H.-P.; Michaelis, A.	Flössel, M.; Lieske, U.; Klesse, T.; Gebhardt, S.	10th International Symposium on Ceramic Materials and Components for Energy and Environmental Applications – CMCEE 2012, Dresden (20.-23.5.2012), Poster, Presentation
Endler, I.; Höhn, M.; Schmidt, J.; Scholz, S.; Herrmann, M.; Knaut, M.	In-situ preparation and thermoelectric properties of B_xC-TiB₂ composites	Ceramic based SHM modules for rough environment	Ganzer, G.; Schöne, J.; Beckert, W.; Megel, S.; Michaelis, A.
TiSiN and TiSiCN hard coatings by CVD	31st International & 10th European Conference on Thermoelectrics – ICT/ECT 2012, Aalborg (9.-12.7.2012), Presentation	ACTUATOR 2012 – International Conference and Exhibition on New Actuators and Drive Systems, Bremen (18.-20.6.2012), p.68-71, Presentation	3D-Modeling of an integrated SOFC stack unit
39th International Conference on Metallurgical Coatings and Thin Films – ICMCTF, San Diego (23.-27.4.2012), Presentation	Feng, B.; Martin, H.-P.; Michaelis, A.	Freytag, C.; Beckert, W.	10th European SOFC Forum – EFCE 2012, Lucerne (26.-29.6.2012), Poster
Ernst, D.; Bramlage, B.; Gebhardt, S.	In-situ preparation and thermoelectric properties of B_xC-TiB₂ composites	Simple thermal-electric modeling of batteries	Gebhardt, S.; Ernst, D.; Bramlage, B.; Flössel, M.; Schönecker, A.
In-plane polarized PZT thick-film actuators by screen printing technology	10th International Symposium on Ceramic Materials and Components for Energy and Environmental Applications – CMCEE 2012, Dresden (20.-23.5.2012), Presentation	15. ITI Symposium, Dresden (14.-16.11.2012), Presentation	Integrated piezoelectrics for adaptive microsystems – A teamwork of substrate and piezo
ACTUATOR 2012 – International Conference and Exhibition on New Actuators and Drive Systems, Bremen (18.-20.6.2012), p.128-131, Presentation	Fries, M.	Pulveraufbereitung	4th International Conference on Smart Materials, Structures and

- Systems – CIMTEC 2012, Montecatini Terme, Tuscany (10.-14.6.2012), Presentation
- Gebhardt, S.; Flössel, M.; Schönecker, A.; Lieske, U.; Klesse, T. **Robust structural health monitoring transducers based on LTCC/PZT multilayer** International Symposium on Applications of Ferroelectrics – ISAF-ECAPD-PFM 2012, Aveiro (9.-13.7.2012), Presentation
- Gestrich, T.; Jaenicke-Röbber, K.; Neher, R.; Herrmann, M. **Analysis of processes during production of powdermetallurgical and ceramic materials** HI TEMP 2012 Conference, Munich (11.-13.9.2012), Presentation
- Gierth, P.; Rebenklau, L. **Evaluation of soldering processes for high-efficiency solar cells** 35th International Spring Seminar on Electronics Technology – ISSE 2012, Bad Aussee (9.-13.5.2012), p.133-137, Presentation
- Glöb, B.; Fries, M.; Nebelung, M. **DoE basierte Korrelation zwischen Formulierung, Prozessparametern und den Eigenschaften keramischer Sprühgranulate** Jahrestreffen der Fachgruppen Agglomerations- und Schüttguttechnik & Kristallisation, Wittenberg (5./6.3.2012), Presentation
- Glöb, B.; Fries, M.; Nebelung, M. **Keramischer Sprühgranulate – DoE basierte Korrelation zwischen Formulierung, Prozessparametern und den Produkteigenschaften** 11. DoE Kongress “Get the best out of it!”, Kassel (10.10.2012), Presentation
- Glöb, B.; Fries, M. **A method for analyzing the die filling behavior of ceramic granules** 7th International Conference for Conveying and Handling of Particulate Solids, Friedrichshafen (10.-13.9.2012), Presentation
- Günther, C.; Richter, H.; Voigt, I. **Sodalite membranes of high thermal and hydrothermal stability – Seeding investigations** 24. Deutsche Zeolith-Tagung, Magdeburg (7.-9.3.2012), Poster
- Gutzeit, N.; Müller, J.; Reinlein, C.; Gebhardt, S. **LTCC membranes with integrated heating structures, temperature sensors and strain gauges** 35th International Spring Seminar on Electronics Technology – ISSE 2012, Bad Aussee (9.-13.5.2012), p.399-405, Presentation
- Haderk, K.; Richter, H.-J. **Additive manufacturing of ceramics – Examples of 3D-printing and laser sintering** Direct Digital Manufacturing Fraunhofer Conference – DDMC 2012, Berlin (14./15.3.2012), Poster
- Hagen, G.; Kopp, T.; Ziesche, S.; Partsch, U.; Ruprecht, E. **Combined 3D-microstructuring of ceramic green tape using punching, embossing and laser processing** 8th International Conference and Exhibition on Ceramic Interconnect and Ceramic Microsystems Technologies – CICMT 2012, IMAPS/ACerS, Erfurt (16.-19.4.2012), p.341-347/WA34, Presentation
- Heddrich, M.; Jahn, M.; Michaelis, A.; Näke, R.; Weder, A. **Dry biogas reforming for 50 % electric system efficiency** 10th International Symposium on Ceramic Materials and Components for Energy and Environmental Applications – CMCee 2012, Dresden (20.-23.5.2012), Presentation
- Heddrich, M.; Jahn, M.; Michaelis, A.; Näke, R.; Weder, A. **Simple and robust biogas fed SOFC system with 50 % electric efficiency – Modeling and experimental results** 10th European SOFC Forum – EFCF 2012, Lucerne (26.-29.6.2012), Presentation
- Herrmann, M.; Sydow, U.; Sempf, K.; Schneider, M.; Michaelis, A. **Elektrochemische Korrosion von Siliciumcarbidwerkstoffen** DKG-Jahrestagung 2012 / Symposium Hochleistungskeramik DKG/DGM 2012, Nuremberg (5.-7.3.2012), Presentation
- Herrmann, M. **Gefügedarstellung und Bewertung** Advancer-Schulungsprogramm Hochleistungskeramik Teil III: Konstruktion, Prüfung, Freiburg (8./9.11.2012), Presentation
- Herrmann, M. **Hochleistungskeramik für korrosive Anwendungen** Advancer-Schulungsprogramm Hochleistungskeramik Teil I: Werkstoffe, Verfahren, Dresden (14.3.2012), Presentation
- Herrmann, M.; Matthey, B.; Räthel, J.; Kinski, I. **Superhard ceramic materials** Freiberg High Pressure Symposium, Freiberg (8.10.2012), Presentation
- Herrmann, M.; Sydow, U.; Sempf, K.; Schneider, M.; Michaelis, A. **Superhard ceramic materials** DKG-Jahrestagung 2012 / Symposium Hochleistungskeramik DKG/DGM 2012, Nuremberg (5.-7.3.2012), Presentation
- Herrmann, M. **Superhard ceramic materials – Myth or reality?** 10th International Symposium on Ceramic Materials and Components for Energy and Environmental Applications – CMCee 2012, Dresden (20.-23.5.2012), Presentation
- Herrmann, M. **Thermische Entbinderungsprozesse: Mechanismen – Methoden – Verfahren** DKG-Fortbildungsseminar – Entbinderung keramischer Formteile, Dresden (11.10.2012), Presentation
- Heubner, C.; Schneider, M.; Michaelis, A. **Spatially resolved in-operando temperature measurement across the interfaces of a Li-ion battery cell** 9th International Symposium on Electrochemical Micro & Nanosystem Technologies – EMNT 2012, Linz (15.-17.8.2012), Presentation
- Himpel, G. **Entbinderungstechnik** DKG-Fortbildungsseminar – Entbinderung keramischer Formteile, Dresden (11.10.2012), Presentation
- Höhn, S. **Charakterisierung der Formkörper, Defektentstehung, Nachweis/Vermeidung** DKG-Fortbildungsseminar – Entbinderung keramischer Formteile, Dresden (11.10.2012), Presentation

- Höhn, S.; Pötschke, J.; Richter, V.
Sinterverhalten von Hartmetallen und Charakterisierung mittels Ionenstrahlpräparation und werkstoffanalytischer Verfahren
46. Metallographie-Tagung der Deutschen Gesellschaft für Materialkunde, Rostock (19.-21.9.2012), p.257-262, Presentation
- Höhn, S.; Eckhard, S.; Fries, M.; Herrmann, M.; Matthey, B.
Structure characterization of ceramic granules, green bodies and pre-sintered compacts based on ion beam preparation techniques
10th International Symposium on Ceramic Materials and Components for Energy and Environmental Applications – CMCEE 2012, Dresden (20.-23.5.2012), Presentation
- Hoyer, T.; Voigt, I.; Fischer, G.; Kämnitz, S.; Köhler, B.; Sikora, R.; Tupaika, F.; Niemi, F.-G.; Schulze, T.
Ceramic hollow fiber contactors for membrane extraction
XXIX EMS Summer School on Membranes, Nancy (10.-13.7.2012), Poster
- Hoyer, T.; Voigt, I.; Fischer, G.; Kämnitz, S.; Köhler, B.; Sikora, R.; Tupaika, F.; Niemi, F.-G.; Schulze, T.
Keramischer Hohlfaserkontaktorkontaktor
8. Thementage Grenz- und Oberflächentechnik, Leipzig (4.-6.9.2012), Poster
- Ihle, M.; Partsch, U.; Mosch, S.; Goldberg, A.
Aerosol printing of high-resolution films for LTCC-multilayer components
8th International Conference and Exhibition on Ceramic Interconnect and Ceramic Microsystems Technologies – CICMT 2012, IMAPS/ACerS, Erfurt (16.-19.4.2012), p.71-76/TA25, Presentation
- Jobst, K.; Deutschmann, A.; Lomtscher, A.; Friedrich, E.
CFD vs. ERT: Der Vergleich zwischen Simulation und Realität
15. Köthener Rührer-Kolloquium, Köthen (14.6.2012), Presentation
- Jobst, K.; Deutschmann, A.; Friedrich, E.
Einsatz der Prozess-Tomographie zur Bewertung von Mischprozessen
Biogas-Forum 2012, Halle (30.3.2012), Presentation
- Johannes, M.; Schneider, J.
Feinstdisperse ZrO₂-und Dispersionskeramik durch innovative Aufbereitungsverfahren
DKG-Jahrestagung 2012 / Symposium Hochleistungskeramik DKG/DGM 2012, Nuremberg (5.-7.3.2012), Presentation
- Jupe, A.; Hoeren, A.; Goehlich, A.; Meißner, F.; Endler, I.; Vogt, H.
Direct integration of carbon nanotubes on CMOS with high-temperature tungsten metallization
4. GMM Workshop Mikro-Nano-Integration, Berlin (12./13.11.2012), Presentation
- Jurk, R.; Fritsch, M.; Partsch, U.; Michaelis, A.
Synthesis and processing of highly silver loaded inks for ink jet printing
9th International Nanotechnology Symposium – Nanofair 2012, Dresden (12./13.6.2012), Poster
- Kinski, I.; Henke, B.; Meinhard, S.; Schweizer, S.; Wätzig, K.
Nano-crystalline SrAl₂O₄ persistent phosphors doped with Eu²⁺ and Dy³⁺
10th International Symposium on Ceramic Materials and Components for Energy and Environmental Applications – CMCEE 2012, Dresden (20.-23.5.2012), Presentation
- Kinski, I.
Precursor-abgeleitete Keramiken
Fraunhofer Symposium "Netzwerk", Munich (4.12.2012), Presentation
- Klemm, H.
Hochleistungskeramik für Hochtemperaturanwendungen
Advancer-Schulungsprogramm Hochleistungskeramik Teil I: Werkstoffe, Verfahren, Dresden (14.-15.3.2012), Presentation
- Klemm, H.; Bales, A.; Schönfeld, K.; Michaelis, A.
Hot gas corrosion and environmental barrier coating development of non-oxide ceramic materials
36th International Conference and Exposition on Advanced Ceramics and Composites – ICACC 2012, Daytona Beach/FL (22.-27.1.2012), Presentation
- Krell, A.; Strassburger, E.
Discrimination of basic influences on the ballistic strength of opaque and transparent ceramics
36th International Conference and Exposition on Advanced Ceramics and Composites – ICACC 2012, Daytona Beach/FL (22.-27.1.2012), p.161-176, Presentation
- Krell, A.
Hochleistungskeramik für Verschleißanwendungen
Advancer-Schulungsprogramm Hochleistungskeramik, Teil I: Werkstoffe, Verfahren, Dresden (14./15.3.2012), Presentation
- Krell, A.
Influences of the cation disorder of commercial spinel powders studied by 27Al MAS NMR on the sintering of transparent MgAl₂O₄ ceramics
10th International Symposium on Ceramic Materials and Components for Energy and Environmental Applications – CMCEE 2012, Dresden (20.-23.5.2012), Presentation
- Kremmer, K.; Schneider, M.
Einfluss der Anodisierungsbedingungen auf die Morphologie – eine Parameterstudie
Symposium "Anodisieren – Vom Korrosionsschutz bis zur Nanotechnologie", Dresden (29.-11.2012), p.39-46, Presentation
- Krenkel, W.; Langhof, N.; Spatz, C.
Design of hybrid ceramic-metal tubes for power plants
10th International Symposium on Ceramic Materials and Components for Energy and Environmental Applications – CMCEE 2012, Dresden (20.-23.5.2012), Presentation
- Kriegel, R.; Schulz, M.; Ritter, K.; Kiesel, L.; Pippardt, U.; Stahn, M.; Voigt, I.
Advanced membrane design for oxygen separation
Sino-German Symposium on Inorganic Membranes for Clean Energy and Clear Environment, Hanover (18.-23.3.2012), Presentation
- Kriegel, R.; Kiesel, L.; Pippardt, U.; Ritter, K.; Schulz, M.
Oxygen permeation of oxygen transporting membrane components
10th International Symposium on

- Ceramic Materials and Components for Energy and Environmental Applications – CMCEe 2012, Dresden (20.-23.5.2012), Presentation
- Kriegel, R.
Oxygen separation using advanced membrane components
Sino-German Symposium on Inorganic Membranes for Clean Energy and Clear Environment, Hanover (18.-23.3.2012), Poster, Presentation
- Kriegel, R.; Schulz, M.
Constructional approach for stability enhancement of BSCF membranes in syngas production
12th International Conference on Inorganic Membranes, Enschede (9.-13.7.2012), Poster
- Kriegel, R.; Ritter, K.; Albert, H.
Fügen keramischer Bauteile durch Reactive Air Brazing
Thüringer Werkstofftag, Weimar (14.3.2012), Poster
- Krug, H. F.; Steinbach, C.; Kühnel, D.; Mathes, B.; Nau, K.; Richter, V.; Scholz, S.; Tryanowski, A.; Zschiesche, M.
DaNa – Knowledge base nano-materials
10th International Symposium on Ceramic Materials and Components for Energy and Environmental Applications – CMCEe 2012, Dresden (20.-23.5.2012), Poster
- Krug, M.; Endler, I.; Brenner, F.; Dirnstorfer, I.; Jakschik, S.; Müller, J.; Sundqvist, J.; Rose, M.; Weber, J.; Liepack, H.; Glöß, D.; Barth, S.; Abidin, A. Z.
ALD-Beschichtungen am Fraunhofer IKTS Dresden
Workshop Nano- und Oberflächentechnologie, Zwickau (8.11.2012), Presentation
- Krug, M.; Endler, I.; Brenner, F.; Dirnstorfer, I.; Müller, J.; Sundqvist, J.; Rose, M.; Jakschik, S.; Weber, J.; Liepack, H.
Aluminium-, Titan- und Silizium-basierte Oxidschichten für verschiedene Anwendungen mittels ALD
EFDS-Workshop, Dresden (7.3.2012), Presentation
- Krug, M.; Endler, I.; Brenner, F.; Dirnstorfer, I.; Jakschik, S.; Müller, J.; Sundqvist, J.; Rose, M.; Weber, J.; Liepack, H.; Glöß, D.; Barth, S.; Abidin, A. Z.
Functional ALD layers beyond microelectronics
SEMICON Europe 2012, Dresden (9.-11.10.2012), Presentation
- Krug, M.; Endler, I.; Brenner, F.; Jakschik, S.; Müller, J.; Rose, M.; Sundqvist, J.
Mixed oxide layers for back side passivation of crystalline silicon solar cells by ALD
10th International Symposium on Ceramic Materials and Components for Energy and Environmental Applications – CMCEe 2012, Dresden (20.-23.5.2012), Presentation
- Kucera, A.; Richter, H.-J.; Moritz, T.
Cold embossing of ceramic green tapes
8th International Conference and Exhibition on Ceramic Interconnect and Ceramic Microsystems Technologies – CICMT 2012, IMAPS/ACerS, Erfurt (16.-19.4.2012), p.328-333/WA31, Presentation
- Kucera, A.; Ziesche, S.; Jurkow, D.; Richter, H.-J.; Malecha, K.; Moritz, T.; Golonka, L.
Development of micro fluidic component by embossing, laser ablation and screen printing
10th International Conference on Multi-Material Micro Manufacture – 4M 2012, Wien (9.-11.10.2012), Presentation
- Kucera, A.; Michaelis, A.; Moritz, T.; Richter, H.-J.
Direct structuring of UV-curable ceramic slurries
10th International Symposium on Ceramic Materials and Components for Energy and Environmental Applications – CMCEe 2012, Dresden (20.-23.5.2012), Poster
- Kucera, A.; Michaelis, A.; Moritz, T.; Richter, H.-J.
Green tape structuring by embossing at room temperature
10th International Symposium on Ceramic Materials and Components for Energy and Environmental Applications – CMCEe 2012, Dresden (20.-23.5.2012), Presentation
- Kucera, A.; Ziesche, S.; Richter, H.-J.; Moritz, T.
Green tapes developed for structuring, lamination and in-mould labeling
10th International Conference on Multi-Material Micro Manufacture – 4M, Wien (9.10.2012), Presentation
- Kucera, A.; Richter, H.-J.; Moritz, T.
Strukturierung keramischer Grünfolien mittels Prägens
DKG-Jahrestagung 2012 / Symposium Hochleistungskeramik DKG/DGM 2012, Nuremberg (5.-7.3.2012), Presentation
- Kühn, S.; Frömmel, A.; Käding, S.; Klein, K.; Pfeiffer, T.; Winkler, L.
Portable LPG-fueled microtubular SOFC
10th International Symposium on Ceramic Materials and Components for Energy and Environmental Applications – CMCEe 2012, Dresden (20.-23.5.2012), Poster
- Kühnert, J.-T.; Voigt, I.; Richter, H.; Weyd, M.; Tröber, O.; Tusel, E.; Brüscke, H.E.A.
Membrane processes for sustainable, energy efficient and economic biorefineries
Industrial Use of Renewable Raw Materials: Chemistry, Biotechnology, Process Engineering – DECHEMA, Frankfurt, (14./15.2.2012), Poster
- Kusnezoff, M.
MEA für Hochtemperaturbrennstoffzellen mit hoher Leistung
13. Wörlitzer Workshop Membrantechnologien und Modifizierung von Membranen, Wörlitz (4.7.2012), p.14, Presentation
- Kusnezoff, M.; Trofimenko, N.; Olenick, J.; Olenick, K.
Performance of electrolyte supported cells based on thin electrolyte
36th International Conference and Exposition on Advanced Ceramics and Composites – ICACC 2012, Daytona Beach/FL (22.-27.1.2012), Presentation
- Lackner, G.; Endler, I.; Meißner, F.; Czeschik, A.; Liebschner, R.; Bezugly, V.; Mayumder, A.; Mkandwire, M.; Boucher, R.; Kovalenko, D.; Lupascu, D.C.
Carbon nanotubes as electrode and acceptor in organic solar cells
Materials Science Engineering – Internationale MSE Tagung 2012, Darmstadt (25.9.2012), Presentation
- Lackner, G.; Endler, I.; Meißner, F.; Scholz, S.; Bezugly, V.; Boucher, R.; Mkandawire, M.; Michaelis, A.;

- Cuniberti, G.; Lupascu, D. C.
Carbon nanotubes in organic solar cell application
Internationaler "Dresden Barkhausen Award" & Dresdner Barkhausen-Poster-Preis, Dresden (2012), Poster
- Lackner, G.; Shvartsmann, V.; Bezugly, V.; Boucher, R.; Endler, I.; Krug, M.; Meißner, F.; Lupascu, D.C.
Dyes and carbon nanotubes
2012 MRS Fall Meeting, Boston (25.-30.11.2012), Poster
- Lackner, G.; Shvartsmann, V.; Endler, I.; Krug, M.; Meißner, F.; Lupascu, D.C.
Dyes in vertically aligned carbon nanotubes
3rd International Conference Organic Photovoltaics, Würzburg (19.9.2012), Poster
- Lämmel, C.; Schneider, M.; Heubner, C.; Michaelis, A.
Anomalies in high field growth of aluminum oxide using pulse anodizing
Vth Aluminium Surface Science & Technology – ASST 2012, Sorrento (27.-31.5.2012), Presentation
- Lämmel, C.; Schneider, M.; Heubner, C.; Michaelis, A.
In-situ temperature measurement on the metal/oxide/electrolyte interface during the anodizing
Vth Aluminium Surface Science & Technology – ASST 2012, Sorrento (27.-31.5.2012), Poster
- Lämmel, C.; Heubner, C.; Schneider, M.; Michaelis, A.
Pulseregime beim Anodisieren – Vorteile und Chancen von diskontinuierlichen Verfahren
Symposium "Anodisieren – Vom Korrosionsschutz bis zur Nanotechnologie", Dresden (29./30.11.2012), p.80-85, Presentation
- Langklotz, U.; Schneider, M.; Michaelis, A.
Anodic oxide formation on mechanically polished TiAlV6-4
Symposium "Anodisieren – Vom Korrosionsschutz bis zur Nanotechnologie", Dresden (29.-30.11.2012), p.104-110, Presentation
- Langklotz, U.; Michaelis, A.; Schneider, M.
Investigation of the water content in electrode materials for Lin-ion batteries
10th International Symposium on Ceramic Materials and Components for Energy and Environmental Applications – CMCee 2012, Dresden (20.-23.5.2012), Presentation
- Langklotz, U.; Schneider, M.; Michaelis, A.
Investigation of the water content in electrode materials for Li-ion batteries
63rd Annual Meeting of the International Society of Electrochemistry – ISE 2012, Prague (19.-24.8.2012), Presentation
- Langklotz, U.; Schneider, M.; Michaelis, A.
Spectroelectrochemical investigations on thin anodic titanium oxide films
Spectroelectrochemistry 2012, Dresden (26.8.2012), Presentation
- Lauenroth, S.; Fischer, G.
Qualifizierung eines alternativen Porenbildners zur Herstellung offenerporiger (großvolumiger) keramisch gebundener Schleifwerkzeuge II
Jahrestagung 2012 der Forschungsgemeinschaft Schleiftechnik e.V., Würzburg (29.3.2012), Presentation
- Lauenroth, S.; Fischer, G.
Wärmespeicher zur standortbezogenen Nutzung von Industrieabwärme – Möglichkeiten und Grenzen
Netzwerk-Dialog OST, Dresden (14.3.2012), Presentation
- Lausch, H.
Drahtlose – berührungslose – autarke Energieversorgung von mikro-nano-integrierten embedded multiple sensor oder sensor-actuator devices
MNT-Branchentag 2012 - "nanogoes makro" zu Potenzialen, Produkten und Dienstleistungen der Mikrotechnik und Nanotechnologie, Ilmenau (12.9.2012), Presentation
- Lausch, H.
Drahtlose Energieübertragungsverfahren mit magnetischer Kopplung
Elektronik Wireless Power Congress, Munich (4.7.2012), Presentation
- Lausch, H.
Energieversorgung bei Implantaten VDE/DGBMT/BMBF Begleitforschung Intelligente Implantate – Expertenworkshops zum Thema "Energie - Daten - Gesamtsystem", Frankfurt (3./4.5.2012), Presentation
- Leiva, D.; Langklotz, U.; Wolter, M.; Schneider, M.
Ex-situ and in-situ raman spectroscopic investigations of lithium-cobalt-oxide electrodes at different state of charge
Spectroelectrochemistry 2012, Dresden (26.-29.8.2012), Poster
- Leiva, D.; Bretthauer, C.; Fritsch, M.; Fauser, G.; Wolter, M.
LiFePO₄ cathodes: Porosity, structural properties and performance
63rd Annual Meeting of the International Society of Electrochemistry, Prague (19.-24.8.2012), Presentation
- Lenz, C.; Ziesche, S.; Partsch, U.; Neubert, H.
Low-temperature cofired ceramics (LTCC)-based miniaturized load cells
35th International Spring Seminar on Electronics Technology – ISSE 2012, Bad Aussee (9.-13.5.2012), Presentation
- Lenzner, K.; Glöb, B.; Eckhard, S.
Granulatcharakterisierung
17. DKG-Fortbildungsseminar – Technologische Grundlagen der Granulierung und Granulatverarbeitung, Dresden (18./19.4.2012), Presentation
- Ludwig, H.
Eigenschaften und innovative Anwendungspotentiale weiterentwickelter oxidkeramischer Hochleistungswerkstoffe
2. Hermsdorfer Werkstoff- und Technologiekolloquium, Hermsdorf (19.9.2012), Presentation
- Luthardt, F.; Morgenstern, A.; Adler, J.
High-temperature insulation materials manufactured via continuous direct foaming
Cellular Materials – CELLMAT 2012, Dresden (7.-9.11.2012), Presentation
- Ma, M.; Müller, M.; Richter, J.; Kriegel, R.; Böhning, D.; Beckmann, M.; Glüsing, J.; Ruhe, N.
Investigation of combined catalyst and oxygen carrier

- systems for the partial oxidation of tars from biomass gasification
20th European Biomass Conference and Exhibition, Milan
(18.-22.6.2012), Presentation
- Mammitzsch, L.; Adler, J.; Petasch, U.
- Pore-size effects on filtration behaviour in a silicon carbide diesel particle filter material**
10th International Symposium on Ceramic Materials and Components for Energy and Environmental Applications – CMCEE 2012, Dresden (20.-23.5.2012), Presentation
- Mannschatz, A.; Schilm, J.; Peschel, M.; Moritz, T.; Michaelis, A.
- Powder injection moulding of conductive glass-carbon composites for electrical resistors**
Powder Metallurgy Congress and Exhibition – Euro PM 2012, Basel (16.-19.9.2012), CD, p.73-78, Presentation
- Marschallek, F.; Herre, R.; Jahn, M.; Michaelis, A.
- Combustion in porous media – Flame monitoring based on the electric properties of open celled silicon carbide foams**
Achema 2012, Frankfurt (18.-22.6.2012), Presentation
- Marschallek, F.; Jahn, M.; Michaelis, A.
- Combustion in porous inert media – Evaluation of flame velocity and new concepts for flame monitoring**
34th International Symposium on Combustion, Warsaw (29.7.-3.8.2012), Poster
- Masover, I.; Herrmann, M.; Räthel, J.; Zuri, L.
- HIP technology trade-offs for alumina-zirconia compositions**
10th International Symposium on Ceramic Materials and Components for Energy and Environmental Applications – CMCEE 2012, Dresden (20.-23.5.2012), Presentation
- Matthey, B.; Höhn, S.; Herrmann, M.; Kinski, I.; Mühle, U.; Rafaja, D.
- Preparation and microstructure characterization of diamond-silicon carbide ceramic composites**
10th International Symposium on Ceramic Materials and Components for Energy and Environmental Applications – CMCEE 2012, Dresden (20.-23.5.2012), Presentation
- Megel, S.; Bienert, C.; Brandner, M.; Kusnezoff, M.; Michaelis, A.; Rissbacher, K.; Sigl, L.; Venskutonis, A.
- CFY stack technology: From electrolyte supported cells to high-efficiency SOFC stacks**
10th International Symposium on Ceramic Materials and Components for Energy and Environmental Applications – CMCEE 2012, Dresden (20.-23.5.2012), Presentation
- Meinl, J.
- Thermoanalytische Untersuchung von Fasermaterialien am Beispiel Polyacrylnitril**
GEFTA Symposium on Thermal Analysis and Calorimetry, Saarbrücken (10.-12.10.2012), Presentation
- Meißner, T.; Potthoff, A.
- Evaluierung von ökotoxikologischen Methoden mit Suspensionsanalysen**
2. Clustertreffen NanoCare/Nano-Nature, Frankfurt (13./14.3.2012), Poster
- Meißner, T.; Oelschlägel, K.
- Nanopartikelcharakterisierung für toxikologische Studien**
VDI Working group Granulometrie, Dresden (18.10.2012), Presentation
- Meißner, T.
- Partikelcharakterisierung für ökotoxikologische Studien**
Gemeinsame Jahrestagung von SETAC GLB und Fachgruppe Umweltchemie und Ökotoxikologie der GDCh: "Erkennen, Untersuchen, Modellieren – Vom Nutzen des Verstehens", Leipzig (10.-13.9.2012), Presentation
- Michaelis, A.
- Ceramics for innovative energy and storage systems**
36th International Conference and Exposition on Advanced Ceramics and Composites – ICACC 2012, Daytona Beach/FL (22.-27.1.2012), Presentation
- Michaelis, A.; Voigt, I.
- New ceramic membranes for energy and environmental applications**
36th International Conference and Exposition on Advanced Ceramics and Composites – ICACC 2012, Daytona Beach/FL (22.-27.1.2012), Presentation
- Moritz, T.
- Fehlerquellen bei der Herstellung keramischer Werkstoffe**
Advancer-Schulungsprogramm Hochleistungskeramik
Teil III: Konstruktion, Prüfung, Freiburg (8./9.11.2012), Presentation
- Moritz, T.
- Formgebung**
Advancer-Schulungsprogramm Hochleistungskeramik
Teil I: Werkstoffe, Verfahren, Dresden (14./15.3.2012), Presentation
- Mosch, S.; Jurk, R.; Fritsch, M.; Hendl, J.; Höhne, J.
- Novel metal nanoparticles and inks for direct writing methods**
9th International Nanotechnology Symposium – Nanofair 2012, Dresden (12./13.6.2012), Poster
- Neher, R.; Herrmann, M.; Gestrich, T.
- High-temperature thermal analysis of sintering silicon carbide with alumina and yttria: Really a liquid phase sintering?**
15th International Conference on Thermal Analysis and Calorimetry – ICTAC 2012, Osaka (20.-24.8.2012), Presentation
- Neher, R.
- Thermische Analyse im Höchsttemperaturbereich – Sintern von SiC mit Y_2O_3 , Al_2O_3 : Wirklich ein Flüssigphasensintern?**
GEFTA Symposium on Thermal Analysis and Calorimetry, Saarbrücken (10.10.2012), Presentation
- Nutto, C.; Bierwisch, C.; Lagger, H.; Moseler, M.; Höhn, S.; Bremerstein, T.; Potthoff, A.
- Towards simulations of abrasive flow machining**
7th International SPHERIC Workshop, Prato (29.-31.5.2012), Presentation
- Oberländer, A.; Kinski, I.; Michaelis, A.; Pezzotti, G.
- Structure and optical properties of cubic gallium oxynitride**
10th International Symposium on Ceramic Materials and Components for Energy and Environmental Applications – CMCEE 2012, Dresden (20.-23.5.2012), Presentation
- Oehme, F.
- Grünbearbeitung technischer**

<p>Hochleistungskeramik: Methoden, Instrumente und Entwicklungsrichtungen Advancer-Schulungsprogramm Hochleistungskeramik, Teil II: Bearbeitung, Berlin (9./10.5.2012), Presentation</p> <p>Oehme, F.</p>	<p>ten und Mikrosysteme Advancer-Schulungsprogramm Hochleistungskeramik, Teil I: Werkstoffe, Verfahren, Dresden (14./15.3.2012), Presentation</p> <p>Petasch, U.; Mammitzsch, L.; Beckert, W.; Adler, J.; Cheng, L.; Wiegmann, A.</p>	<p>Pohl, M.; Jahn, M.; Locke, C.; Michaelis, A.</p> <p>Prozessintensivierung in Hinblick auf das Temperaturverhalten eines SSiC-Katalysatorsystems bei der partiellen Oxidation 45. Jahrestreffen Deutscher Katalytiker, Weimar (14.-16.3.2012), Poster</p>	<p>Pönicke, A.; Arnold, S.; Schilm, J.; Kusnezoff, M.; Michaelis, A.</p> <p>Reactive air-brazed ceramic-metal seals for SOFC: Mechanical properties and long-term behavior 10th International Symposium on Ceramic Materials and Components for Energy and Environmental Applications – CMCEe 2012, Dresden (20.-23.5.2012), Presentation</p>
<p>Hochpräzisionsbearbeitung mittels Koordinatenschleifen Advancer-Schulungsprogramm Hochleistungskeramik, Teil II: Bearbeitung, Berlin (9.-10.5.2012), Presentation</p>	<p>Hocheffiziente keramische Filtermedien für die Rußpartikelfiltration 10. FAD-Konferenz "Herausforderung – Abgasnachbehandlung für Dieselmotoren", Dresden (7./8.11.2012), Presentation</p>	<p>Pohl, M.; Jahn, M.; Locke, C.; Michaelis, A.</p> <p>Startverhalten keramischer Brennstoffzellenkomponenten Jahrestreffen Reaktionstechnik, Würzburg (14.-16.5.2012), Poster</p>	<p>Pönicke, A.; Schilm, J.; Kusnezoff, M.</p> <p>Reaktivlöten von Keramik-Metall-Verbunden an Luft: Ein Vergleich von induktiver und konventioneller Erwärmung DKG Symposium Fügen von Keramik, Erlangen (4.12.2012), Presentation</p>
<p>Olenick, J.; Kusnezoff, M.; Michaelis, A.; Olenick, K.; Trofimenko, N.</p>	<p>Pfeifer, T.; Nusch, L.; Beckert, W.</p> <p>System concept and process layout for a micro-CHP unit based on low-temperature SOFC 10th European SOFC Forum – EFCF 2012, Lucerne (26.-29.6.2012), Presentation</p>	<p>Pönicke, A.; Reuber, S.; Dosch, C.; Megel, S.; Kusnezoff, M.; Wunderlich, C.; Michaelis, A.</p> <p>Efficient planar SOFC technology for a portable power generator 36th International Conference and Exposition on Advanced Ceramics and Composites – ICACC 2012, Daytona Beach/FL (22.-27.1.2012), p.125-136, Presentation</p>	<p>Pötschke, J.; Richter, V.; Michaelis, A.</p> <p>Pressure-assisted sintering of WC ceramics Freiberg High Pressure Symposium, Freiberg (8.-10.10.2012), Poster</p>
<p>Electrolyte supported cells based on an ultrathin 3YSZ substrate 10th International Symposium on Ceramic Materials and Components for Energy and Environmental Applications – CMCEe 2012, Dresden (20.-23.5.2012), Presentation</p>	<p>Pfeifer, T.; Barthel, M.; Männel, D.; Koszyk, S.</p> <p>System integration of micro-tubular SOFC for a LPG-fueled portable power generator 10th European SOFC Forum – EFCF 2012, Lucerne (26.-29.6.2012), Poster</p>	<p>Pönicke, A.; Arnold, S.; Schilm, J.; Kusnezoff, M.; Michaelis, A.</p> <p>Mechanical properties of reactive air-brazed ceramic-metal joints for SOFC 5th International Brazing and Soldering Conference, Las Vegas (22.-25.4.2012), p.450-457, Presentation</p>	<p>Pötschke, J.; Richter, V.; Gestrich, T.</p> <p>Sintering behaviour of binderless tungsten carbide Powder Metallurgy Congress and Exhibition – Euro PM 2012, Basel (16.-19.9.2012), CD, Presentation</p>
<p>Olenick, J.; Kusnezoff, M.; Trofimenko, N.; Michaelis, A.; Melvin, C.; Lazzaretto, A.</p>	<p>Ultrathin flexible electrolyte supported cells ASME 2012 International Mechanical Engineering Congress & Exposition, Houston/TX (9.-15.11.2012), Presentation</p>	<p>Pohl, M.; Jahn, M.</p> <p>Fast start-up with ceramic fuel cell components Achema 2012, Frankfurt (18.-22.6.2012), Presentation</p>	<p>Potthoff, A.</p> <p>Aussagen und Grenzen der Partikelmesstechnik bei der Rohstoffanmusterung 49. Sitzung des Arbeitskreises Hartmetall, Bayreuth (24.10.2012), Presentation</p>
<p>Partsch, U.; Griebmann, H.; Claus, R.; Bach, S.</p>	<p>Pohl, M.; Jahn, M.; Locke, C.; Michaelis, A.</p> <p>Form follows function – A parametric study of ceramic based CPO-reforming catalyst for hydrogen production 7th International Conference on Environmental Catalysis – ICEC, Lyon (2.-6.9.2012), Presentation</p>	<p>Pönicke, A.; Reuber, S.; Dosch, C.; Megel, S.; Kusnezoff, M.; Wunderlich, C.; Michaelis, A.</p> <p>Portable 100 W power generator based on efficient planar SOFC technology 36th International Conference and Exposition on Advanced Ceramics and Composites – ICACC 2012, Daytona Beach/FL (22.-27.1.2012), Presentation</p>	<p>Potthoff, A.</p> <p>Characterization of nanoparticles DGM-Fortbildungskurs "Nano-scale materials and advanced characterization techniques", Dresden (5./6.12.2012), Presentation</p>
<p>Dickschicht- und Multilayer-basierte keramische Komponenten für die Kunststoffverarbeitung Tagung Verarbeitungsmaschinen, Verpackungstechnik – VVD 2012, Dresden (22./23.3.2012), p.199-209, Presentation</p>	<p>Partsch, U.</p> <p>Multilayerbasierte Komponenten</p>		

- Potthoff, A.; Lenzner, K.
Einfluss des Energieeintrages bei der Aufbereitung auf die Granulateigenschaften
Jahrestagung der UVR-FIA "Aufbereitung&Recycling", Freiberg (8.11.2012), Presentation
- Potthoff, A.; Bremerstein, T.; Klohe, K.; Meyer, A.; Rödel, C.
Einfluss von Partikelparametern auf die rheologischen Eigenschaften von Suspensionen
Malvern-Seminar, Dresden (26.1.2012), Presentation
- Potthoff, A.
Pulver- und Suspensionscharakterisierung
17. DKG-Fortbildungsseminar – Technologische Grundlagen der Granulierung und Granulatverarbeitung, Dresden (18./19.4.2012), Presentation
- Rabbow, T.; Gierth, U.; Schneider, M.; Michaelis, A.
Nanoparticle surface modifications of screen-printed sensors for enhanced sensitivity
9th International Nanotechnology Symposium – Nanofair, Dresden (12./13.6.2012), Presentation
- Rabbow, T.J.; Weiser, M.; Schneider, M.; Michaelis, A.
Pulse Plating for electrocatalytic fuel cell and sensor applications
2. Workshop Oberflächentechnik, Ilmenau (6./7.9.2012), Presentation
- Räthel, J.; Beckert, W.; Herrmann, M.
FAST/SPS temperature distribution during heating ramp
10th International Symposium on Ceramic Materials and Components for Energy and Environmental Applications – CMCEE 2012, Dresden (20.-23.5.2012), Presentation
- Rebenklau, L.; Gierth, P.; Mehlich, H.; Hausmann, J.; Grimm, M.; Stein, W.; Bell, H.; Clement, C.; Vogg, F.
Low-temperature interconnection techniques for high-efficiency heterojunction solar cells
27th European Photovoltaic Solar Energy Conference and Exhibition – EU PVSEC, Frankfurt (24.-28.9.2012), Poster
- Rechberger, J.; Kusnezoff, M.; Rissbacher, K.
Modular SOFC20 system approach
10th International Symposium on Ceramic Materials and Components for Energy and Environmental Applications – CMCEE 2012, Dresden (20.-23.5.2012), Presentation
- Reichel, U.
Ceramic materials based on nanopowders
Nanotechnology Forum, St. Petersburg (3.7.2012), Presentation
- Reichel, U.
Optokeramische Werkstoffe: Stand und Vorhaben
Präsentation bei JenaOptronik GmbH, Jena (27.6.2012)
- Reimann, T.; Töpfer, J.; Barth, S.
Low-temperature sintered NTC ceramics for thick-film temperature sensors and multi-layer thermistors
8th International Conference and Exhibition on Ceramic Interconnect and Ceramic Microsystems Technologies – CICMT 2012, IMAPS/ACerS, Erfurt (16.-19.4.2012), p.536-541/WP4, Presentation
- Reinhardt, K.
Bleioxid-freie Kupfer-Dickschicht-Pasten für mehr Designflexibilität in der Leistungselektronik
DKG-Jahrestagung 2012 / Symposium Hochleistungskeramik DKG/DGM 2012, Nuremberg (5.-7.3.2012), Presentation
- Reinhardt, K.; Rebenklau, L.; Partsch, U.; Sontag, D.; Steiner, A.; Waltinger, A.
Nondestructive analyses of back contact formations at LoBaCo solar cells
27th European Photovoltaic Solar Energy Conference and Exhibition – EU PVSEC, Frankfurt (24.-28.9.2012), Poster
- Reichel, U.
Ceramic nanomaterials – Research & Development
Nanotechnology Forum, St. Petersburg (3.7.2012), Poster
- Reichel, U.; Johannes, M.; Ludwig, H.
Innovative Anwendungen oxidkeramischer Werkstoffe
Thüringer Werkstofftag, Weimar (14.3.2012), Poster
- Reichel, U.; Johannes, M.; Ludwig, H.
Innovative Anwendungen oxidkeramischer Werkstoffe
3. Jenaer Industriertage, Jena (28./29.03.2012), Poster
- Reuber, S.
A modul-based approach for multi-objective design and optimization of solid oxide fuel cell systems
10th European SOFC Forum – EFCF 2012, Lucerne (26.-29.6.2012), Presentation
- Reuber, S.; Pönicke, A.; Pfeifer, T.; Wunderlich, C.
- eneramic® – Entwicklungsstand des mobilen SOFC-Stromgenerators
Sächsisches Forum für Brennstoffzellen und Energiespeicher, Leipzig (23.10.2012), Presentation
- Reuber, S.; Pönicke, A.; Wunderlich, C.; Michaelis, A.
Portable 100 W power generator based on efficient planar SOFC technology
10th International Symposium on Ceramic Materials and Components for Energy and Environmental Applications – CMCEE 2012, Dresden (20.-23.5.2012), Presentation
- Richter, H.; Kämnitz, S.; Weyd, M.; Voigt, I.; Lubenau, U.; Mothes, R.
Adsorption selective carbon membranes for CO₂-separation
12th International Conference on Inorganic Membranes, Enschede (9.-13.7.2012), Poster
- Richter, H.; Weyd, M.; Kämnitz, S.; Kaltenborn, N.; Wöhner, S.; Voigt, I.; Mothes, R.; Lubenau, U.
CO₂-abtrennende Membran zur Biomethanherstellung
12. Treffen des BioMethan-Kuratoriums des BBK und der FEE, Hermsdorf (4.6.2012), Presentation
- Richter, H.; Voigt, I.; Kaltenborn, N.; Kämnitz, S.; Voss, H.; Terre, J.; Kuhn, J.
H₂-selective mole sieving carbon membranes
12th International Conference on Inorganic Membranes, Enschede (9.-13.7.2012), Presentation
- Richter, H.; Puhlfürß, P.; Kociemba, P.; Voigt, I.
Keramische Nanofiltrationsmembran mit einer Trenngrenze von 200 D: Neue Anwendungs-

möglichkeiten in der Papierindustrie PTS Fachseminar "Membrantechnik in der Papierindustrie", Munich (11./12.6.2012), Presentation	Ceramic Materials and Components for Energy and Environmental Applications – CMCEE 2012, Dresden (20.-23.5.2012), Presentation	Gleixner, A. Effiziente Bioethanolherstellung durch Nutzung der SBR-Technologie und Einsatz von Pervaporation zur Produktabtrennung 16. Heiligenstädter Kolloquium, Heilbad Heiligenstadt (24.-26.9.2012), Poster, Presentation	Rödig, T. Benchmarking of piezoceramic materials for generator application 14th Leibniz Conference of Advanced Science "Sensorsysteme 2012", Lichtenwalde (18./19.10.2012), Presentation
Richter, H.; Voigt, I. Large-scale ceramic membranes fabrication Pd Membrane Technology Scale-up Workshop, Rome (12.-14.11.2012), Presentation	Richter, H.-J.; Kucera, A.; Moritz, T. Fabrication of ceramic tapes with nano-zirconia powder 10th International Symposium on Ceramic Materials and Components for Energy and Environmental Applications – CMCEE 2012, Dresden (20.-23.5.2012), Presentation	Richter, V.; Meißner, T.; Kühnel, D. Development of nano-structured materials requires a continuous consideration of health and environmental aspects 10th International Symposium on Ceramic Materials and Components for Energy and Environmental Applications – CMCEE 2012, Dresden (20.-23.5.2012), Presentation	Rödig, T.; Schönecker, A. Innovative Keramiken für effiziente Generatoren Fraunhofer-Workshop "Energieautarke Sensornetzwerke", Berlin (16.2.2012), Presentation
Richter, H.; Voigt, I.; Weyd, M. Robust gas separation porous ceramic membranes Innovation for Sustainable Production – i-SUP 2012, Bruges (6.-10.5.2012), Presentation	Richter, H.-J.; Adler, J.; Mazitschek, K.; Petasch, U. New technology and equipment for alternating plugging of DPF honeycombs 10th International Symposium on Ceramic Materials and Components for Energy and Environmental Applications – CMCEE 2012, Dresden (20.-23.5.2012), Poster	Richter, V.; Pötschke, J.; Holke, R. Development of the microstructure of nano-structured materials during sintering Powder Metallurgy World Congress & Exhibition – World PM 2012, Yokohama (14.-18.10.2012), Presentation	Rödig, T. Innovative Keramiken für piezoelektrische Generatoren Advancer-Schulungsprogramm Hochleistungskeramik, Teil I: Werkstoffe, Verfahren, Dresden (14.-15.3.2012), Presentation
Richter, H. Trennen durch Sieben – Keramische Membranen in der Flüssigfiltration und Gastrennung GdCH Ortsverband Aalen-Ostalb, Aalen (20.11.2012), Presentation	Richter, H.-J.; Ahlhelm, M.; Haderk, K. Process and material development for laser sintering of silicon carbide Direct Digital Manufacturing Fraunhofer Conference – DDMC 2012, Berlin (14./15.3.2012), Presentation	Richter, V.; Pötschke, J. Grain growth and the role of grain growth inhibitors in sintering nano-scaled ceramic powders 10th International Symposium on Ceramic Materials and Components for Energy and Environmental Applications – CMCEE 2012, Dresden (20.-23.5.2012), Presentation	Rödig, T.; Schönecker, A. Preparation and characterization of acoustic transducers based on KNN-ceramics IEEE International Ultrasonics Symposium 2012, Dresden (7.-10.10.2012), Presentation
Richter, H.; Voigt, I. Zeolite hollow fibers Sino-German Symposium on Inorganic Membranes for Clean Energy and Clear Environment, Hanover (18.-23.3.2012), Presentation	Richter, H.-J.; Kriegel, R.; Voigt, I.; Kahn, R.; Glüsing, J.; Ruhe, N.; Beckmann, M.; Böhning, D.; Müller, M.; Ma, M. A combined catalyst and oxygen carrier system for the processing of tar containing gases 7th International Conference on Environmental Catalysis - ICEC 2012, Lyon (2.-6.9.2012), Poster	Richter, V.; Pötschke, J. Grain growth and the role of grain growth inhibitors in sintering nano-scaled ceramic powders 10th International Symposium on Ceramic Materials and Components for Energy and Environmental Applications – CMCEE 2012, Dresden (20.-23.5.2012), Presentation	Röhländer, D. Roh- und Werkstoffcharakterisierung Mitarbeiterschulung für PI Ceramic, Hermsdorf (22.2.2012), Presentation
Richter, H.; Voigt, I. Zeolithmembranen – Stand der Entwicklung und Anwendung ProcessNet-Jahrestagung und 30. DECHEMA-Jahrestagung der Biotechnologen 2012, Karlsruhe (10.-13.9.2012), Presentation	Richter, H.-J.; Günther, C.; Lenke, N.; Voigt, I. Thermal and hydrothermal stable zeolite membranes for H₂ separation 10th International Symposium on	Rödig, T. Benchmarking of piezoceramic materials for generator application 10th International Symposium on Ceramic Materials and Components for Energy and Environmental Applications – CMCEE 2012, Dresden (20.-23.5.2012), Presentation	Rösler, G.; Häusler, A.; Blätter, M. Niedrig-Temperatur-Sinterung von Porzellan auf ultraleichten, hochporösen Brennplatten in mit Holzgas beheizten Schnellbrandöfen 9. BMBF-Forum Forschung für Nachhaltigkeit – FONa, Berlin (22./23.10.2012), Poster

Scheithauer, U.; Haderk, K.; Mannschatz, A.; Michaelis, A.; Richter, H.-J.; Scholl, R.; Slawik, T. Development of graded ceramics by ceramic tape and lamination technology 10th International Symposium on Ceramic Materials and Components for Energy and Environmental Ap- plications – CMCee 2012, Dresden (20.-23.5.2012), Presentation	Electrochemical Micro & Nanosys- tem Technologies – EMNT 2012, Linz (15.-17.8.2012), Presentation	Dreikönigskirche, Dresden (25.6.- 10.7.2012), Poster, Presentation	Fachtagung Energiepflanzen für die Biogasproduktion, Trossin (29.8.2012), Presentation
Schilm, J.; Rost, A.; Kusnezoff, M. Lithium-Ionen leitende Glaskera- miken als funktionelle Kompo- nenten in Sekundär-Batterien FORGLAS Workshop spin-off- Projekte, Spiegelau (3.7.2012), Presentation	Schneider, M.; Leiva, D.; Fauser, G.; Bretthauer, C.; Barth, S.; Fritsch, M.; Schneider, M.; Langklotz, U.; Partsch, U.; Wunderlich, C. Characterization of processing technologies for Li-ion battery manufacturing Kraftwerk Batterie, Münster (6./7.3.2012), Poster	Schönecker, A. Smart structures with integrated piezoelectric transducers – Aspects of design and use of series technologies 64th ICAT Smart Actuator Symposium, State College/PA (2./3.10.2012), Presentation	Schwarz, B. Stand und neueste Entwicklung der Substratvorbehandlung für den Biomasseeinsatz in Biogas- anlagen 3. Biogastagung Landwirtschafts- kammer Niedersachsen "Anlagen- und Prozessoptimierung", Verden (23.2.2012), Presentation
Schmale, K.; Grünebaum, M.; Kämpfer, A.; Koops, S.; Pippardt, U. Investigations on the conducti- vity of doped ceria composite materials 10th International Symposium on Ceramic Materials and Components for Energy and Environmental Applications – CMCee 2012, Dresden (20.-23.5.2012), Poster	Schneider, M.; Kremmer, K.; Weidmann, S.K.; Fürbeth, W. Interplay between parameter variation and oxide structure of a modified PAA process 6th Aluminium Surface Science & Technology – ASST 2012, Sorrento (27.-31.5.2012), Presentation	Schönfeld, K.; Klemm, H.; Michaelis, A. Ceramic components based on non-oxide fibre composite mate- rials for advanced systems in the hightemperature energy tech- nology 36th International Conference and Exposition on Advanced Ceramics and Composites – ICACC 2012, Daytona Beach/FL (22.-27.1.2012), Presentation	Schwarz, B.; Wufka, A. Stand und Perspektiven der Nut- zung lignocellulosehaltiger Rest- stoffe für die Biogasproduktion Biogas Workshop IKTS, Dresden (9.5.2012), Presentation
Schmidt, J.; Kinski, I.; Michaelis, A.; Uhlig, S. Plasma-enhanced chemical va- pour deposition (PECVD) of ZnO for TCO application 10th International Symposium on Ceramic Materials and Components for Energy and Environmental Ap- plications – CMCee 2012, Dresden (20.-23.5.2012), Presentation	Schneider, M.; Schubert, N.; Michaelis, A. Investigation of anodic dissolu- tion of cobalt in alkaline solution 8th International Symposium on ElectroChemical Machining Technology – INSECT, Krakow (18./19.10.2012), Presentation	Schubert, N.; Schneider, M.; Michaelis, A. ECM of tungsten carbide in am- moniacal solution – Investiga- tion of anodic dissolution 8th International Symposium on ElectroChemical Machining Technology – INSECT 2012, Krakow (18./19.10.2012), Presentation	Schwarz, B. Wirtschaftlichkeit von Biogas- anlagen auf Basis des EEG 2012 Biogas Workshop IKTS, Dresden (9.5.2012), Presentation
Schneider, M.; Langklotz, U.; Michaelis, A. The anomaly of a thickness de- pendent relative permittivity in ultrathin anodic oxide films 9th International Symposium on	Schneider, M.; Langklotz, U.; Sempf, K. Korrosion im Alltag – Schaden am Fahrrad GfKORR-Jahrestagung 2012, Frankfurt (6./7.11.2012), Presentation	Schulz, M.; Kriegel, R.; Ritter, K. Experimental studies and modeling of oxygen flux in BSCF capillary modules 10th International Symposium on Ceramic Materials and Components for Energy and Environmental Ap- plications – CMCee 2012, Dresden (20.-23.5.2012), Presentation	Schwarz, B. Wirtschaftlichkeit von Biogas- anlagen auf Basis des EEG 2012 Abschlussveranstaltung Bioenergie- netzwerk Sächsische Schweiz- Osterzgebirge, Dohna (28.6.2012), Presentation
Schneider, M.; Langklotz, U.; Michaelis, A. The anomaly of a thickness de- pendent relative permittivity in ultrathin anodic oxide films 9th International Symposium on	Scholz, J. Strom aus (Ab-)Wärme – Ther- moelektrisch aktive Materialien machen es möglich 14. Sächssicher Landeswettbewerb zur Umsetzung der Agenda 21 in der beruflichen Bildung 2011/2012, Ausstellung der Ergebnisse,	Schwarz, B.; Reinhold, G. Potenziale und Wirtschaftlich- keit von Stroh als Substrat in Nassvergärungsanlagen	Sempf, K.; Bauer, F.; Herrmann, M. Analysis of thickness and com- position of thin-films 10th International Symposium on Ceramic Materials and Components for Energy and Environmental Ap- plications – CMCee 2012, Dresden (20.-23.5.2012), Presentation
Schneider, M.; Langklotz, U.; Michaelis, A. The anomaly of a thickness de- pendent relative permittivity in ultrathin anodic oxide films 9th International Symposium on	Scholz, J. Strom aus (Ab-)Wärme – Ther- moelektrisch aktive Materialien machen es möglich 14. Sächssicher Landeswettbewerb zur Umsetzung der Agenda 21 in der beruflichen Bildung 2011/2012, Ausstellung der Ergebnisse,	Schwarz, B.; Reinhold, G. Potenziale und Wirtschaftlich- keit von Stroh als Substrat in Nassvergärungsanlagen	Seuthe, T.; Ihle, M.; Kretzschmar, C.; Ziesche, S. Ag-Pasten für hochstromtragfä- hige Spulen in LTCC-Leistungs- elektronik

- DKG-Jahrestagung 2012 / Symposium Hochleistungskeramik DKG/DGM 2012, Nuremberg (5.-7.3.2012), Presentation
- Seuthe, T.; Grehn, M.; Mermillod-Blondin, A.; Rosenfeld, A.; Eichler, H. J.; Bonse, J.; Eberstein, M.
Effects of single-pulse femtosecond laser irradiation on the structure of silicate glasses
11th ESG Conference and 86. DGG-Jahrestagung, Maastricht (4.-7.6.2012), Presentation
- Simon, A.; Kaiser, S.; Kämnitz, S.; Schulz, M.; Richter, H.; Voigt, I.
Synthese und Charakterisierung von Carbon Nanotubes für die Energie- und Umwelttechnik
Thüringer Werkstofftag, Weimar (14.3.2012), Poster
- Slawik, T.
Anwendung papiertechnologischer Verfahren zur Darstellung von Halbzeugen für flächenhafte funktionelle Metall- und Metall-Nichtmetall-Schichtverbunde
23. Jahreshauptversammlung des APV Dresden, Dresden (8.6.2012), Presentation
- Slawik, T.
Anwendung papiertechnologischer Verfahren zur Entwicklung von zwei- und dreidimensionalen keramischen und metall-keramischen Werkstoffverbund-Bauteilen:
Hans-Walter-Hennicke Vortragswettbewerb, DKG-Jahrestagung 2012 / Symposium Hochleistungskeramik DKG/DGM 2012, Nuremberg (5.-7.3.2012), Presentation
- Slawik, T.; Baumann, A.; Großmann, H.; Handke, T.; Michaelis, A.; Moritz, T.; Scheithauer, U.; Scholl, R.
Ceramic and metal-ceramic product concepts based on papertechnological processes
10th International Symposium on Ceramic Materials and Components for Energy and Environmental Applications – CMCee 2012, Dresden (20.-23.5.2012), Presentation
- Slawik, T.; Moritz, T.
Spiral winding of green tapes
Junior Euromat 2012, Lausanne (23.-27.7.2012), Poster
- Sommer, E.; Kriegel, R.; Voigt, I.
Sauerstoff-Normal für die Online-Kalibrierung in der Prozess-Analytik
Thüringer Werkstofftag, Weimar (14.3.2012), Presentation
- Sonntag, F.; Schmieder, F.; Ziesche, S.; Rabbow, T.; Schmieder, S.; Bürger, M.; Klotzbach, U.
Universelle Plattform für die automatisierte, amperometrische Überwachung von Reportergen-assays
4. Dresdner Medizintechnik Symposium, Dresden (3.-5.12.2012), Presentation
- Standke, G.; Quadbeck, P.; Kümmel, K.; Balzer, H.; Wierhake, A.
Transfer of manufacturing process for stainless-steel foam to industrial-scale
Cellular Materials – CELLMAT 2012, Dresden (7.11.2012), Presentation
- Stockmann, J.
Uniaxiales Pressen
17. DKG-Fortbildungsseminar – Technologische Grundlagen der Granulierung und Granulatverarbeitung, Dresden (18./19.4.2012), Presentation
- Stockmann, J.
Verbindungstechnik
Advancer-Schulungsprogramm Hochleistungskeramik Teil III: Konstruktion, Prüfung, Freiburg (8./9.11.2012), Presentation
- Suffner, J.; Rost, A.
Glaskeramische Werkstoffe zur Fügung von hochchromhaltigen Metallen mit Keramiken zum Einsatz in der Hochtemperatur-brennstoffzelle (SOFC)
DKG Symposium Fügen von Keramik, Erlangen (4.12.2012), Presentation
- Thiele, M.; Herrmann, M.
B₂O₃ ceramics prepared by near-ambient and high-pressure sintering technologies
Freiberg High Pressure Symposium, Freiberg (8.10.2012), Presentation
- Thiele, M.; Herrmann, M.
Boron suboxide (B₂O₃) with oxide additives for cutting and wear applications
Freiberg High Pressure Symposium, Freiberg (8.10.2012), Presentation
- Toma, L.-F.; Berger, L.-M.; Langner, S.; Potthoff, A.; Rödel, C.; Scheitz, S.
Suspension spraying – Advances and potentials of a new thermal spray technology
10th International Symposium on Ceramic Materials and Components for Energy and Environmental Applications – CMCee 2012, Dresden (20.-23.5.2012), Presentation
- Tröber, O.; Kahle, H. I.; Trentsch, S.; Richter, H.; Heft, A.; Grünler, B.; Spange, S.
Stabilizing of photochromic dyes by encapsulation inside mesoporous aluminosilicate nanoparticles
24. Deutsche Zeolith-Tagung, Magdeburg (7.3.2012), Presentation
- Tröber, O.; Richter, H.; Voigt, I.
Zeolite-filled PDMS membranes for pervaporation
24. Deutsche Zeolith-Tagung, Magdeburg (7.-9.3.2012), Poster
- Tröber, O.; Richter, H.; Weyd, M.; Brüsckhe, H.; Tusel, E.
Zeolite-filled PDMS/PAN membranes for separation of low concentrated alcohol/water mixtures
Euromembrane 2012, London (23.-27.9.2012), Poster
- Uhlig, S.; Schmidt, J.; Michaelis, A.; Kinski, I.
Comparative study on doped ZnO
27th European Photovoltaic Solar Energy Conference and Exhibition – EU PVSEC, Frankfurt (24.-28.9.2012), Presentation, Poster
- Voigt, I.; Richter, H.; Kriegel, R.
Anorganische Membranen für die Flüssigfiltration und Gas-trennung
13. Wörlitzer Workshop "Membrantechnologien und Modifizierung von Membranen", Wörlitz (4.7.2012), Presentation
- Voigt, I.; Richter, H.; Weyd, M.
Ceramic membranes for an efficient biomass conversion
DKG-Jahrestagung 2012 / Symposium Hochleistungskeramik DKG/DGM 2012, Nuremberg (5.-7.3.2012), Presentation
- Voigt, I.; Richter, H.; Kriegel, R.;

Weyd, M. Ceramic membranes for vapour permeation and gas separation IMeTI & CARENA Workshop on Inorganic Membrane Technology, Montpellier (27.-28.3.2012), Presentation	Arbeitsstreffen Wissenschaftliche Netzwerk "Silane", Düsseldorf (26.1.2012), Presentation	aligned MWCNT for PEMFC 5th European Pulse Plating Seminar, Wien (9.3.2012), Poster	Olmo, M. F. Fouling resistant ceramic honeycomb nanofilters for efficient water treatment - trends of project CeraWater 2nd Dissemination Workshop of the Nano4water Cluster, Thessaloniki (24.-25.4.2012), Presentation
Voigt, I.; Puhlfürß, P.; Richter, H.; Endter, A.; Duscher, S.; Herrmann, K. Ceramic NF-membranes with a cut-off of 200 Da 12th International Conference on Inorganic Membranes, Enschede (9.-13.7.2012), Presentation	Wätzig, K.; Krell, A.; Michaelis, A. Highly transparent MgAl₂O₄ spinel prepared by powder of sol gel synthesis 10th International Symposium on Ceramic Materials and Components for Energy and Environmental Applications – CMCEE 2012, Dresden (20.-23.5.2012), Presentation	Weiser, M.; Dörfler, S.; Schneider, M.; Althues, H.; Michaelis, A.; Kaskel, S. Platinum pulse plating on aligned MWCNT for the application in PEMFC 9th International Nanotechnology Symposium – Nanofair 2012, Dresden (12.-13.6.2012), Poster	Weyd, M.; Prehn, V. Keramische Mikro-, Ultra- und Nanofiltrationsmembranen für die Energie und Umwelttechnik Ceramatec 2012, Munich (22.-25.5.2012), Presentation
Voigt, I.; Kriegel, R.; Sommer, E. Effiziente Sauerstofferzeugung für Verbrennungs- und Vergasungsprozesse ThEGA-Forum, Erfurt (11.10.2012), Presentation	Wätzig, K.; Grimm, M.; Kinski, I.; Michaelis, A. Microcrystalline silicon thin-films using PECVD and high-order silanes 10th International Symposium on Ceramic Materials and Components for Energy and Environmental Applications – CMCEE 2012, Dresden (20.-23.5.2012), Presentation	Weiser, M.; Dörfler, S.; Schneider, M.; Althues, H.; Michaelis, A.; Kaskel, S. Platinum pulse plating on aligned MWCNTs for PEMFC 10th International Symposium on Ceramic Materials and Components for Energy and Environmental Applications – CMCEE 2012, Dresden (20.-23.5.2012), Poster	Weyd, M.; Richter, H.; Stahn, M.; Puhlfürß, P.; Voigt, I. CeraWater – Ceramic membranes für water treatment Aachener Membran Kolloquium, Aachen (7.-8.11.2012), Poster
Voigt, I.; Hoyer, T.; Fischer, G.; Kämnitz, S.; Köhler, B.; Sikora, R.; Tupaika, F.; Niemi, F. G.; Schulze, T. Keramischer Hohlfaserkontakt für die Membranextraktion Thüringer Werkstofftag, Weimar (14.3.2012), Poster	Wätzig, K. Transparent spinel ceramic – New perspectives of a well-known material 7th International Scientific & Technological Conference – Polish Ceramics 2012, Krakow (9.-12.9.2012), Presentation	Weiser, M.; Dörfler, S.; Schneider, M.; Althues, H.; Michaelis, A.; Kaskel, S. Pulse plating of platinum nanoparticles on aligned multi-walled CNTs 9th International Symposium on Electrochemical Micro & Nanosystem Technologies – EMNT 2012, Linz (15.-17.8.2012), Presentation	Wolter, M.; Fauser, G.; Bretthauer, C.; Roscher, M.A. End-of-line testing and formation process in Li-ion battery assembly lines 9th International Multi-Conference on Systems, Signals and Devices – SSD, Chemnitz (20.-23.3.2012), Presentation
Voigt, I. Nano-Kohlenstoffsichten für Anwendungen in der Membrantechnik und Katalyse 2. Fachtagung Nano-Kohlenstoff, Augsburg (28.9.2012), Presentation	Weiser, M.; Dörfler, S.; Schneider, M.; Althues, H.; Michaelis, A.; Kaskel, S. Platinum pulse plating on aligned MWCNTs for PEMFC 3rd CARISMA International Conference on medium and high Temperature PEM Fuel Cells, Copenhagen (3.-6.9.2012), Presentation	Weyd, M.; Richter, H.; Tröber, O.; Hoyer, T.; Voigt, I. Bio-alcohol concentration by pervaporation with organophilic zeolite membranes – Influence of protective coatings on fouling tendency Euromembrane 2012, London (23.-27.9.2012), Presentation	Wolter, M.; Potthoff, A.; Knecht, F.; Meißner, T. Fertigung von Elektroden für Lithium-Ionen-Batterien – Spezifische Anforderungen an lufttechnische Anlagen aus Prozesssicht 3. ULT-Symposium – Lufttechnik für Zukunftstechnologien, Löbau (29.3.2012), Presentation
Voigt, I.; Puhlfürß, P.; Herrmann, K.; Duscher, S.; Richter, H. New ceramic nanofiltration membranes with a cut-off below 450 D Achema 2012, Frankfurt (18.-22.6.2012), Presentation	Wätzig, K. Erhöhung der Abscheidungsrate von Si-Schichten mit höheren Silanen	Weiser, M.; Dörfler, S.; Schneider, M.; Althues, H.; Michaelis, A.; Kaskel, S. Platinum nanoparticles on	Wolter, M.; Bretthauer, C.; Wunderlich, C.; Roscher, M.A. Industrial production of Li-ion battery cells and systems – Scale-up from lab to fab

Advanced Automotive Battery Conference – AABC Europe 2012, Mainz (18.-22.6.2012), Poster	Wunderlich, C.; Kusnezoff, M.; Megel, S.; Schilm, J.; Pönicke, A.; Mai, B.E.	Ceramitec 2012, Munich (22.-25.5.2012), Presentation	Dr. Jahn, M. Lecture and practice "Chemische Verfahrenstechnik/ Reaktionstechnik" HTW Dresden, Chemieingenieurwesen (SS 12; WS 12/13)
Wufka, A. Breitenwirksame, wirtschaftliche Biogasgewinnung aus hoch lignozellulosehaltigen biogenen Reststoffen Energetische Biomassenutzung – Neue Technologien und Konzepte für die Bioenergie der Zukunft, Berlin (5./6.11.2012), Presentation	Status Entwicklung SOFC Stack-technologie am Fraunhofer IKTS DGM Fortbildungsseminar "Werkstofffragen der Hochtemperatur-Brennstoffzelle (SOFC)", Jülich (9.-11.5.2012), Presentation	Zins, M. Treffpunkt Keramik – Durch Kooperation zur Innovation Ceramitec 2012, Munich (22.-25.5.2012), Presentation	Dr. Jahn, M. Lecture "Verfahrenstechnische Entwicklung eines SOFC-Systems für den Einsatz von Biogas" in the course "Apparate und Anlagen" TU Dresden, Fakultät Maschinenwesen, Institut für Verfahrenstechnik und Umwelttechnik, degree course Verfahrenstechnik (9.1.2012)
Wufka, A. Potenziale und Wirtschaftlichkeit von Stroh als Substrat in Nassvergärungsanlagen Fachverband Biogas: "Neuentwicklungen in der Biogastechnologie in Mitteldeutschland", Halle (25.10.2012), Presentation	Zeidler, S.; Puhlfürß, P.; Kätzel, U.; Voigt, I. Solvent nanofiltration with a molecular weight cut-off < 500 Da Euromembrane 2012, London (23.-27.9.2012), Presentation	Teaching activities of IKTS employees	
Wufka, A. Strohmonovergärung Bioenergie-Tag, Applikationszentrum Bioenergie Pöhl (6.3.2012), Presentation	Zelm, R.; Handke, T.; Slawik, T.; Moritz, T.; Scholl, R. Anwendung papiertechnologischer Verfahren zur Erzeugung metallkeramischer Werkstoffverbunde Internationales ECEMP-Kolloquium 2012, Dresden (25./26.10.2012), Presentation	Dr. Barth, S. Lecture "Keramische Verfahrenstechnik" Ernst-Abbe-Fachhochschule Jena, Department Scitec (WS 12/13)	Dr. Jahn, M. Lecture "Brennstoffzellen", in the course "Keramische Werkstoffe – anorganisch-nichtmetallische Hochleistungswerkstoffe" TU Dresden, Institut für Werkstoffwissenschaft (27.1.2012)
Wunderlich, C. Die Brennstoffzelle – Was vermagen sie wirklich? Energiesammtisch Elbland, Radebeul (10.4.2012), Presentation	Ziesche, S.; Ihle, M.; Eberstein, M. High-current conductors in LTCC 8th International Conference and Exhibition on Ceramic Interconnect and Ceramic Microsystems Technologies – CICMT 2012, IMAPS/ACerS, Erfurt (16.-19.4.2012), p.25-29/TA14, Presentation	Dr. Eberstein, M. Lecture "Technologie der Keramik" Technische Universität Berlin, Fakultät III, Prozesswissenschaften, Werkstoffwissenschaften und -technologien/Keramische Werkstoffe (WS12/13)	Dr. Jahn, M. Lecture "Verfahrenstechnische Entwicklung eines SOFC-Systems für den Einsatz von Biogas" HTW Berlin, degree course Regenerative Energietechnik (30.10.2012)
Wunderlich, C. Mobile Stromgeneratoren auf Brennstoffzellenbasis Fraunhofer Symposium "Netzwerk", Munich (4./5.12.2012), Presentation	Zins, M. Anwendung und Lieferanten keramischer Hochleistungskomponenten Advancer-Schulungsprogramm Hochleistungskeramik, Teil I: Werkstoffe, Verfahren, Dresden (14./15.3.2012), Presentation	Dr. Fries, M. Lecture "Produktgestaltung keramische Sprühgranulate" Georg-Simon-Ohm, Hochschule Nuremberg (5.12.2012)	Dr. Jahn, M. Lecture "Keramische Verfahrenstechnik" Ernst-Abbe-Fachhochschule Jena, Department Scitec (WS 12/13)
Wunderlich, C. Sächsische Brennstoffzellen im internationalen Wettbewerb IHK Forum Brennstoffzelle, Dresden (31.5.2012), Presentation	Zins, M. Technische Keramik – Keramische Komponenten für die Energie und Umwelttechnik	Dr. habil. Herrmann, M. Lecture and student affairs "Technische Keramische Werkstoffe" University of Witwatersrand, Johannesburg, South Africa (03/2012 and 09/2012)	Dr. Kriegel, R. Lecture "Keramische Verfahrenstechnik" Ernst-Abbe-Fachhochschule Jena, Department Scitec (WS 12/13)
		Dipl.-Ing. Höhn, S. Lecture "Keramografie", in the course "Metallografie" TU Dresden, Institut für Werkstoffwissenschaft (30.1.2012)	Prof. Dr. Michaelis, A.; Dr. Kusnezoff, M.; Dr. Stelter, M.; Dr. Partsch, U.; Dr. Jahn, M.; Heddrich, M. Lecture "Keramische Funktionswerkstoffe" TU Dresden, Institut für

Werkstoffwissenschaft (SS 12)

Prof. Dr. Michaelis, A.

Lecture and practical training
"Keramische Werkstoffe"
TU Dresden, Institut für Werkstoff-
wissenschaft (WS 11/12; WS 12/13)

Prof. Dr. Michaelis, A.;

Dr. Rebenklau, L.;

Dr. Schönecker, A.

Chapter: "Technologien der Dick-
schichttechnik" in the lecture series
"Hybridtechnik"
TU Dresden, Fakultät Elektrotechnik
und Informationstechnik (WS 11/12)

Dr. Moritz, T.

Lecture
"Keramikspritzgießen"
Ernst-Abbe-Fachhochschule Jena
(22.11.2012)

Dr. Moritz, T.

Lecture
"Keramikspritzgießen"
TU Bergakademie Freiberg
(15.6.2012)

Dr. Moritz, T.

Lecture
"Grundlagen der Technischen
Keramik"
Kunsthochschule Halle, Burg
Griebichenstein (WS 12/13)

Dr. Rebenklau, L.

Lecture
"Dickschichttechnik" and "Multi-
layerkeramik" in the course of Prof.
Michaelis "Funktionskeramik"
TU Dresden, Institut für Werkstoff-
wissenschaft (SS 12)

Dr. Stelter, M.

Lecture
"Technische Chemie I"
Friedrich-Schiller-Universität Jena
(SS 12; WS 12/13)

Dipl.-Ing. Svoboda, H.;

Dr. Fries, M.

Lecture
"Pulveraufbereitung und -konfek-
tionierung" in the course "Kerami-
sche Werkstoffe"
TU Dresden, Institut für Werkstoff-
wissenschaft (9.11.2012)

Dr. Voigt, I.

Lecture
"Keramische Verfahrenstechnik"
Fachhochschule Jena, Department
Scitec (WS 12/13)

Dr. Zins, M.

Lecture
"Metalle, Kunststoffe, Keramiken –
Technische Keramik als Leichtbau-
stoff"
TU Dresden, Institut für Werkstoff-
wissenschaft (WS 11/12, WS 12/13)

**Participation in bodies and
technical committees**

Bodies

Dr. Krell, A.

- Associate Editor of "Journal of
the American Ceramic Society"

Prof. Dr. Michaelis, A.

- Editorial Board of "Journal of Ce-
ramic Science and Technology"
- Editorial Board of "International
Journal of Materials Research"
- Publication series "Kompetenzen
in Keramik", Michaelis, A.
(Hrsg.), Stuttgart: Fraunhofer IRB
Verlag, Start 2006
- Publication series "Kompetenzen
in Keramik und Umweltverfah-
renstechnik", Michaelis, A.
(Hrsg.), Stuttgart: Fraunhofer IRB
Verlag, Start 2008

Prof. Dr. Michaelis, A.

- AGEF e.V. Institut at Heinrich-
Heine-Universität, Arbeitsgemein-
schaft Elektrochemischer Forsch-
ungsinstitutionen e.V., Member
- Forschungszentrum Dresden
Rossendorf, Member
- DECHEMA Gesellschaft für
Chemie Technik und Biotechnolo-
gie e.V., Member
- DGM Deutsche Gesellschaft für
Materialkunde, Member
- "World Academy of Ceramics"
WAC, Member
- WAC Forum Committee
(2010-2014), Cooperation
- DKG Member of Executive
Board and chairman of For-
schungsgemeinschaft der Deut-
schen Keramischen Gesellschaft
- DGM/DKG joint committee
"Hochleistungskeramik", Wor-
king Group "Koordinierung"
- DGM/DKG joint committee
"Hochleistungskeramik", Wor-
king Group "Funktionskeramik",
Director
- DECHEMA working committee
"Angewandte Anorganische
Chemie"
- Fraunhofer AdvanCer Alliance,
Spokesman
- DPG-Deutsche Physikalische
Gesellschaft
- Institute Council of IfWW, TU
Dresden
- Company Roth & Rau, Member
of Supervisory Board
- AiF Wissenschaftlicher Rat
- Solarvalley Mitteldeutschland
e.V., Executive Board
- Scientific Advisory Board "Photo-
voltaik Silicon Saxony", Member
- FH Council of Westsächsische
Hochschule Zwickau, Member
- Dresdner Gesprächskreis der
Wirtschaft und Wissenschaft e.V.
- NanoChem, BMBF, consultant
- Evaluation team "Interne

Programme" of Fraunhofer
Gesellschaft, Member

- Steering committee of Innovati-
onszentrum Energieeffizienz,
TU Dresden
- Advisory Board of eZelleron GmbH
- Executive Board of Materialfor-
schungsverbund Dresden e.V.
MFD, Member
- Energiebeirat des Wirtschaftsmini-
steriums Sachsen
- Advisory Board of Industrielles
Netzwerk Erneuerbare Energien
Sachsen EESA
- Dresden concept e.V.
- Clean Tech Media Award,
Member of the jury
- Evaluation team "Märkte von
Übermorgen" of Fraunhofer-Ge-
sellschaft, consultant

Dr. Richter, H.

- International Zeolite Association

Dr. Voigtsberger, B.

- DKG Member of Presidential
Council and Executive Board
- DGM/DKG joint committee
"Hochleistungskeramik", Wor-
king Group "Koordinierung",
chairman
- FH Council of Fachhochschule
Jena
- MNT Mikro-Nano-Technologie
Thüringen e.V., Member of Exe-
cutive Board
- Wirtschaftsbeirat der Ministerprä-
sidentin Thüringens
- IHK Ostthüringen zu Gera,
Ausschuss für Industrie und
Forschung

Dr. Wunderlich, C.

- Energy Saxony e.V., Executive
Board and Deputy Chairman
- Fuel Cell Energy Solutions GmbH,
Member of Advisory Board
- European Fuel Cell Forum,
International Board of Advisors

Technical committees

Dipl.-Krist. Adler, J.

- DGM technical committee "Zelluläre Werkstoffe"
- FAD-Förderkreis "Abgasnachbehandlungstechnologien für Dieselmotoren e.V."

Dr. Beckert, W.

- Fraunhofer Alliance "Numerische Simulation von Produkten und Prozessen" NUSIM

Dipl.-Math. Brand, M.

- Technical committee "Schallemissionsprüfung (SEP)" of Deutsche Gesellschaft für zerstörungsfreie Prüfung DGZfP

Dr. Faßauer, B.

- Fraunhofer SysWasser Alliance
- Wasserwirtschaftliches Energiezentrum Dresden – e.qua impuls e.V.

Freund, Susanne

- Fraunhofer AdvanCer Alliancer, central office

Dr. Friedrich, E.

- Fachverband "Biogas"

Dr. Fries, M.

- DGM/DKG Working Group "Verarbeitungseigenschaften synthetischer keramischer Rohstoffe", Director
- DKG technical committee FA III "Verfahrenstechnik"
- ProcessNet technical group "Agglomerations- und Schüttguttechnik", Member of Advisory Board
- ProcessNet technical group "Trocknungstechnik", Member of Advisory Group

Dr. Gestrich, T.

- Joint committee "Pulvermetallur-

gie", expert group "Sintern"

- GEFTA Working Group "Thermophysik"

Dipl.-Ing. Gronde, B.

- Gemeinschaft "Thermisches Spritzen e.V."
- DVS Working Group "Thermisches Spritzen"

Dr. Herrmann, M.

- DGM technical committee "Thermodynamik, Kinetik und Konstruktion der Werkstoffe"

Dipl.-Ing. Jaenicke-Rößler, K.

- DGM technical committee "Field Assisted Sintering Technique/Spark Plasma Sintering"

Dipl.-Ing. Jaenicke-Rößler, K.

- GEFTA Working Group "Thermophysik"
- GEFTA Working Group "Messunsicherheit von Thermodynamometern"

Dr. Klemm, H.

- DKG Working Group "Verstärkung keramischer Stoffe"
- DIN Committee for Standardization "Materialprüfung NMP 291"
- Carbon Composites e.V., Working Group "Ceramic Composites"

Kunath, R.

- Working Group "Dresdner Informationsvermittler e.V."
- Working Group "Spezialbibliotheken"

Dr. Kusnezoff, M.

- DIN/VDE, Referat K 141, DKE Deutsche Kommission, "Elektrotechnik Elektronik Informationstechnik"
- Working Group "Aufbau- und Verbindungstechnik für Hochtemperatursensoren"

Dr. Lausch, H.

- VDE/VDI Gesellschaft Mikroelektronik, Mikro- und Feinwerktechnik, GMM technical committee 4.7 Mikro-Nano-Integration
- VDE/DGMT/BMBF Begleitforschung Intelligente Implantate, external member
- Fraunhofer-Gesellschaft e.V., Forschungsplanung, Fraunhofer Discover Markets 2030

Dipl.-Ing. Lincke, Marc

- ANS e.V. technical committee "Biokohle"

Dipl.-Ing. Ludwig, H.

- DGM technical committee "Biomaterialien"

Dr. Moritz, T.

- ENMAT "European Network of Materials Research Centres", Vice President
- Management Committee of COST action MP0701 "Nanocomposite Materials"
- DECHEMA technical committee "Nanotechnologie"
- DKG expert group "Keramik-spritzguss", Chairman of Executive Board
- Editorial Board of cfi/Ber. DKG, chairman

Dipl.-Phys. Mürbe, J.

- VDI-Bezirksverein Dresden, Working Group "Granulometrie"

Nake, K.

- DGM Working Group "Härteprüfung und AWT", technical committee "FA-12"

Dr. Petasch, U.

- FAD-Förderkreis "Abgasnachbehandlungstechnologien für Dieselmotoren e.V."

Dipl.-Ing. Pönicke, A.

- DVS-Ausschuss für Technik, Working Group W3 "Fügen von Metall, Keramik und Glas"

Dr. Potthoff, A.

- DGM/DKG Working Group "Prozessbegleitende Prüfverfahren"
- DECHEMA/VCI Working Group "Responsible Production and Use of Nanomaterials"
- Fraunhofer Nanotechnology Alliance

Dipl.-Ing Rätchel, J.

- DGM technical committee "Field Assisted Sintering Technique / Spark Plasma Sintering"

Dr. Rebenklau, L.

- VDI/VDE-GMM technical committee 5.5 "Aufbau- und Verbindungstechnik"
- VDE/VDI-Gesellschaft für Mikroelektronik, Mikro- und Feinwerktechnik
- Working Group "Aufbau- und Verbindungstechnik für Hochtemperatursensoren"

Dr. Reichel, U.

- DKG technical committee "Werkstoffanwendungen"
- DKG Working Group "Verarbeitungseigenschaften synthetischer keramischer Rohstoffe"
- DGM technical committee "Field Assisted Sintering Technique/ Spark Plasma Sintering"

Dr. Richter, H.-J.

- DGM/DKG joint committee "Hochleistungskeramik", Working Group "Keramische Membranen"
- DGM/DKG joint committee "Hochleistungskeramik", Working Group "Biokeramik"
- DGM/DKG joint committee

- "Hochleistungskeramik",
Working Group "Generative
Fertigung keramischer Kompo-
nenten"
- Dr. Richter, V.**
- VDI technical committee
"Schneidstoffanwendung"
 - DECHEMA/VCI Working Group
"Responsible Production and Use
of Nanomaterials"
 - DGM Working Group "Material-
kundliche Aspekte der Tribologie
und der Endbearbeitung"
 - DIN Committee for Standardiza-
tion "Werkstofftechnologie"
(NWT), AA "Probenahme und
Prüfverfahren für Hartmetalle"
 - DIN Committee for Standardiza-
tion "Materialprüfung" (NMP),
AA "Nanotechnologien"
 - DGM/DKG joint committee "Pul-
vermetallurgie", expert group
"Sintern"
 - Fraunhofer Nanotechnology Alli-
ance
 - EPMA Working Group "European
Hard Materials Group"
- Dr. Rost, Axel**
- DVS-Ausschuss für Technik,
Working Group W3 "Fügen von
Metall, Keramik und Glas"
- Dr. Schilm, J.**
- DGG technical committee "Phy-
sik und Chemie des Glases"
 - DKG/DGG Working Group "Gla-
sigkristalline Multifunktionswerk-
stoffe"
 - DVS-Ausschuss für Technik,
Working Group W3 "Fügen von
Metall, Keramik und Glas"
- Dr. Schönecker, A.**
- Advisory Board of Smart Material
GmbH Dresden
- Dipl.-Chem. Schubert, R.**
- DKG expert group "Keramik-
spritzguss"
- Standke, Gisela**
- DGM technical committee
"Zellulare Werkstoffe"
- Dipl.-Ing. Stahn, M.**
- VDI-Entwicklung, Konstruktion,
Vertrieb
- Dr. Stelter, M.**
- DGM/DKG joint committee
"Hochleistungskeramik",
Working Group "Energie"
 - DGM technical committee
"Werkstoffe der Energietechnik"
- Dipl.-Min. Thiele, S.**
- GTS-Gemeinschaft Thermisches
Spritzen e.V.
- Dr. Voigt, I.**
- GVC technical committee
"Produktionsintegrierte Wasser-
und Abwassertechnik"
 - ProcessNet working committee
"Membrantechnik"
 - DGM/DKG joint committee
"Hochleistungskeramik", Wor-
king Group "Keramische
Membranen", Director
 - DGM/DKG joint committee
"Hochleistungskeramik", Wor-
king Group "Koordinierung"
- Dr. Wunderlich, C.**
- VDI technical committee "Brenn-
stoffzellen"
- Dr. Zins, M.**
- DKG coordination group "Struk-
turwerkstoffe Fachausschüsse"
 - Technical committee "Pulverme-
tallurgie"
 - DKG technical committee "Kera-
mikanwendungen"
 - Deutsche Messe AG, Advisory
- Board "Industrial Supply"
- Messe Munich, Advisory Board
"Ceramitec"
 - Institut für Prozess- und Anwen-
dungstechnik Keramik, RWTH
Aachen, Executive Board
- Advisory boards for symposia
and conferences**
- Prof. Dr. Michaelis, A.**
- Vision Keramik 2014
 - ProcessNet DECHEMA-Diskussi-
onstagung "Anorganisch-Techni-
sche Chemie", Frankfurt (2012),
preparatory committee
 - DKG-Jahrestagung 2012 /
Symposium Hochleistungskera-
mik DKG/DGM 2012, Nuremberg
(5.-7.3.2012)
 - 10th International Symposium on
Ceramic Materials and Compo-
nents for Energy and Environ-
mental Applications – CMCEe,
Dresden (20.-23.5.2012), organi-
zational committee
 - Materials Science Engineering –
Internationale MSE Tagung 2012,
Darmstadt (25.-27.9.2012)
 - 3. Dresdner Werkstoffsymposium
"Werkstoffe für die Mobilität",
Dresden, TU Dresden IfWW
(6./7.12.2012)
- Dipl.-Min. Adler, J.**
- 10th International Symposium on
Ceramic Materials and Compo-
nents for Energy and Environ-
mental Applications – CMCEe,
Dresden (20.-23.5.2012),
program section "High-tempera-
ture ceramic filters and membra-
nes", organizational committee
- Dr. Eberstein, M.**
- 10th International Symposium on
Ceramic Materials and Compo-
nents for Energy and Environ-
mental Applications – CMCEe,
Dresden (20.-23.5.2012), pro-
gram section "Advanced function-
al ceramic materials and sys-
tems", organizational committee
- Dr. Endler, I.**
- 10th International Symposium on
Ceramic Materials and Compo-
nents for Energy and Environ-
mental Applications – CMCEe,
Dresden (20.-23.5.2012), pro-
gram section "Ceramic coatings
for structural, environmental and
functional applications – Ceramic
thin-films", organizational com-
mittee
- Dr. Faßbauer, B.**
- 10th International Symposium on
Ceramic Materials and Compo-
nents for Energy and Environ-
mental Applications – CMCEe,
Dresden (20.-23.5.2012),
program section "Advanced
structural ceramics for energy
and environmental technology",
organizational committee
- Freund, S.**
- AdvanCer training program
"Hochleistungskeramik Teil I:
Werkstoffe, Verfahren", IKTS
Dresden (14./15.3.2012)
- Dr. Fries, M.**
- 17th DKG Training seminar
"Technologische Grundlagen der
Granulierung und Granulatverar-
beitung", IKTS Dresden/
TU Dresden (18./19.4.2012),
program organizer
 - 5. DKG/DGM Working Group
meeting "Verarbeitungseigen-
schaften synthetischer Roh-
stoffe", IKTS Dresden
(22.3.2012), program organizer
- Gronde, B.**
- 10th International Symposium on

- Ceramic Materials and Components for Energy and Environmental Applications – CMCEE, Dresden (20.-23.5.2012), program section “Ceramic coatings for structural, environmental and functional applications – Ceramic spray coatings”, organizational committee
- Dr. Gestrich, T.**
- 31. Hagener Symposium Pulvermetallurgie “Pulvermetallurgie – zukunftsweisend vom Rohstoff bis zur Anwendung”, Hagen (29./30.11.2012), program committee
- Dr. Herrmann, M.**
- 10th International Symposium on Ceramic Materials and Components for Energy and Environmental Applications – CMCEE, Dresden (20.-23.5.2012), program section “Novel, green and energy efficient processing and manufacturing technologies” and program section “Nanoscaled ceramic powders and fibers, their properties and applications”, organizational committee
 - 2nd meeting of the DGM technical committee “Field Assisted Sintering Technique/Spark Plasma Sintering”, IKTS Dresden (13.11.2012)
- Dr. Klemm, H.**
- 10th International Symposium on Ceramic Materials and Components for Energy and Environmental Applications – CMCEE, Dresden (20.-23.5.2012), program section “Advanced structural ceramics for energy and environmental technology” and program section “Ceramic matrix composites”, organizational committee
- Dr. Kinski, I.**
- 10th International Symposium on Ceramic Materials and Components for Energy and Environmental Applications – CMCEE, Dresden (20.-23.5.2012), program section “Precursor derived ceramics/Persistent phosphors and luminescent materials”, organizational committee
- Dr. Krell, A.**
- 10th International Symposium on Ceramic Materials and Components for Energy and Environmental Applications – CMCEE, Dresden (20.-23.5.2012), program section “Transparent ceramics”, organizational committee
- Dr. Kusnezoff, M.**
- 10th International Symposium on Ceramic Materials and Components for Energy and Environmental Applications – CMCEE, Dresden (20.-23.5.2012), program section “SOFC materials and Technology”, organizational committee
- Dr. Martin, H.-P.**
- 10th International Symposium on Ceramic Materials and Components for Energy and Environmental Applications – CMCEE, Dresden (20.-23.5.2012), program section “Energy harvesting systems”, organizational committee
- Dr. Potthoff, A.**
- 10th International Symposium on Ceramic Materials and Components for Energy and Environmental Applications – CMCEE, Dresden (20.-23.5.2012), program section “Nanoscaled ceramic powders and fibers, their properties and applications”, organizational committee
- Dr. Partsch, U.**
- 10th International Symposium on Ceramic Materials and Components for Energy and Environmental Applications – CMCEE, Dresden (20.-23.5.2012), program section “Ceramic materials and systems for energy conversion and storage” and program section “Advanced functional ceramic materials and systems”, organizational committee
- Dr. Rebenklau, L.**
- 10th International Symposium on Ceramic Materials and Components for Energy and Environmental Applications – CMCEE, Dresden (20.-23.5.2012), program section “Advanced functional ceramic materials and systems”, organizational committee
- Dr. Richter, V.**
- 10th International Symposium on Ceramic Materials and Components for Energy and Environmental Applications – CMCEE, Dresden (20.-23.5.2012), program section “Nanoscaled ceramic powders and fibers, their properties and applications”, organizational committee
- Dr. Schönecker, A.**
- 10th International Symposium on Ceramic Materials and Components for Energy and Environmental Applications – CMCEE, Dresden (20.-23.5.2012), program section “Energy harvesting systems” and program section “Transparent ceramics”, organizational committee
- Dr. Schneider, M.**
- 10th International Symposium on Ceramic Materials and Components for Energy and Environmental Applications – CMCEE, Dresden (20.-23.5.2012), program section “Ceramic materials and systems for energy conversion and storage”, organizational committee
- Dr. Stelter, M.**
- 10th International Symposium on Ceramic Materials and Components for Energy and Environmental Applications – CMCEE, Dresden (20.-23.5.2012), program section “Novel, green and energy efficient processing and manufacturing technologies”, organizational committee
 - Sächsisches Forum für Brennstoffzellen und Energiespeicher, Leipzig (23.10.2012), program committee
- Dr. Voigt, I.**
- 12th International Conference on Inorganic Membranes, Enschede, Netherlands (9.-13.7.2012), committee
 - 10th International Symposium on Ceramic Materials and Components for Energy and Environmental Applications – CMCEE, Dresden (20.-23.5.2012), program section “High-temperature ceramic filters and membranes”, organizational committee
- Dr. Voigtsberger, B.**
- DKG-Jahrestagung 2012/Symposium Hochleistungskeramik DKG/DGM 2012, Nuremberg (5.-7.3.2012)
- Dr. Wätzig, K.**
- 10th International Symposium on Ceramic Materials and Components for Energy and Environmental Applications – CMCEE, Dresden (20.-23.5.2012), program section “Ceramic materials and systems for energy conversion and storage” and program section “Advanced functional ceramic materials and systems”, organizational committee

nents for Energy and Environmental Applications – CMCee, Dresden (20.-23.5.2012), program section “Persistent phosphors and luminescent materials”, organizational committee

Dr. Wolter, M.

- 10th International Symposium on Ceramic Materials and Components for Energy and Environmental Applications – CMCee, Dresden (20.-23.5.2012), program section “Ceramic materials and systems for energy conversion and storage”, organizational committee

Dr. Wunderlich, C.

- 10th European SOFC Forum – EFCF 2012, Lucerne (26.-29.6.2012), Advisory Board

Dr. Zins, M.

- CERAMITEC Forum “Tag der Technischen Keramik”, Munich (24.5.2012)

Dissertations

Heddrich, Marc Philipp

Thermodynamische Analyse von SOFC-Systemkonzepten und experimentelle Validierung
Dissertation 2012
IKTS Dresden – TU Clausthal, Institut für Metallurgie

Kavurucu Schubert, Sena

Effects of hydrogen sulfide in fuel gas on SOFC stack performance with nickel containing anodes
Dissertation 2012
IKTS Dresden – TU Dresden, Fakultät Maschinenwesen

Meißner, Tobias

Methoden der Nanopartikelcharakterisierung zur Optimierung toxikologischer Studien
Dissertation 2012
IKTS Dresden – TU Dresden, Fakultät Maschinenwesen

Meyer, Anja

Einfluss der Mahlung auf die Stabilität von Böhmit in wässrigen Suspensionen
Dissertation 2012
IKTS Dresden – Universität Karlsruhe, Fakultät Maschinenbau, Institut für Angewandte Materialien-Angewandte Werkstoffphysik

Nicolai, Michael

Polarisierungsverhalten von Piezokeramik unter kombinierter elektrischer, mechanischer und thermischer Beanspruchung
Dissertation 2012
IKTS Dresden – TU Dresden, Fakultät Maschinenwesen, Institut für Werkstoffwissenschaft

Rost, Axel

Entwicklung degradationsstabiler Glaslote für keramische Hochtemperaturbrennstoffzellen
Dissertation 2012
IKTS Dresden – TU Dresden, Fakultät Maschinenwesen, Institut für Werkstoffwissenschaft

Diploma theses

Abel, Johannes

Einfluss des Feuchtegehalts keramischer Feedstocks auf die Verarbeitungseigenschaften und die Qualität spritzgegossener Bauteile
Diploma theses 2012
IKTS Dresden – TU Dresden, Fakultät Maschinenwesen

Bernhard, Matthias

Leitfähigkeitsuntersuchungen an

mischleitenden Membranen

Master theses 2012

IKTS Hermsdorf – Ernst-Abbe-Fachhochschule Jena, Fachbereich Sci-Tec

Bindernagel, Daniel

Untersuchung des Trennverhaltens von Zeolithmembranen
Bachelor theses 2012
IKTS Hermsdorf – Ernst-Abbe-Fachhochschule Jena, Fachbereich Sci-Tec

Brieskorn, Leander

Untersuchung von Gaszusätzen auf das Wachstum gerichteter Carbon Nanotubes unter Verwendung unterschiedlicher Katalysatoren
Diploma theses 2012
IKTS Dresden – TU Dresden, Fakultät Maschinenwesen

Friedrich, Felix

Labortechnische Untersuchungen zur biologischen Hydrolyse von mechanisch-enzymatisch vorbehandelten lignocellulosehaltigen Reststoffen
Diploma theses 2012
IKTS Dresden – TU Dresden, Fakultät für Forst-, Geo- und Hydrowissenschaften, Institut für Abfallwirtschaft und Altlasten

Furche, Stefan

Entwicklung und Charakterisierung von Glasmatrixkomponenten als poröse Abdeckschicht für Multilayer basierte Referenzelektroden
Diploma theses 2012
IKTS Dresden – HTW Dresden, Fakultät Maschinenbau/Verfahrenstechnik

Göbel, Martin

Charakterisierung und elektrochemische Bewertung eines Mikro-SOFC-Stack
Diploma theses 2012

IKTS Dresden – TU Dresden, Fakultät Maschinenwesen

Große, Frieder

Labortechnische Untersuchungen zur quasikontinuierlichen Vergärung von lignocellulosehaltigen Reststoffen
Diploma theses 2012
IKTS Dresden – TU Dresden, Fakultät für Forst-, Geo- und Hydrowissenschaften, Institut für Abfallwirtschaft und Altlasten

Herre, Robert

Untersuchung der temperaturabhängigen elektrischen Eigenschaften offenzelliger keramischer Schäume aus Siliziumkarbid
Diploma theses 2012
IKTS Dresden – TU Dresden, Fakultät Elektrotechnik und Informationstechnik

Heubner, Christian

In-situ Temperaturmessung über die Phasengrenzen einer Lithiumionen-batteriezele
Diploma theses 2012
IKTS Dresden – TU Dresden, Fakultät Maschinenwesen

Hofacker, Martin

Entwicklung einer integrierten Trocknungsmethode für dünnwandige keramische Extrudate
Master theses 2012
IKTS Hermsdorf – Ernst-Abbe-Fachhochschule Jena, Fachbereich Sci-Tec

Höfgen, Eric

Herstellung und Charakterisierung von dotierten BaMgAl₁₀O₁₇-Pulvern (BAM) unterschiedlicher Partikelgröße
Bachelor theses 2012
IKTS Dresden – TU Bergakademie Freiberg, Institut für Mechanische

Verfahrenstechnik und Aufbereitungstechnik

Kanz, Jana

Untersuchung einer kombinierten Nachbrenner-Reformer-Einheit für den Einsatz in einem Hochtemperaturbrennstoffzellensystem
Diploma theses 2012
IKTS Dresden – TU Dresden, Fakultät Maschinenwesen

Killer, Mathias

Entwicklung und Untersuchung von Regelungsverfahren für direkt bestromte Hochtemperatur-Gaserhitzer in der Brennstoffzellen-Systementwicklung
Diploma theses 2012
IKTS Dresden – Hochschule Lausitz, Fakultät für Ingenieurwissenschaften und Informatik

Klohe, Kathrin

Maßgeschneiderte TiO₂-Schichten durch Anpassung der Parameter beim Suspensionsspritzen
Diploma theses 2012
IKTS Dresden – Fraunhofer IWS Dresden – TU Dresden, Fakultät Maschinenwesen

Klose, Patrick

Herstellung und Charakterisierung keramischer Formkörper über die Gießformgebung auf Basis von Zirkoniumoxid
Diploma theses 2012
IKTS Dresden – TU Dresden, Fakultät Maschinenwesen

Knaus, Anton

Entwicklung und Erprobung von alternativen Beschichtungsverfahren zur Herstellung von gasdichten asymmetrischen sauerstoffpermeablen Membranen
Bachelor theses 2012
IKTS Dresden – Ernst-Abbe-Fach-

hochschule Jena, Fachbereich Sci-Tec

Knies, Franziska

Entwicklung der Direktstrukturierung UV-härtbarer Grünfolien
Diploma theses 2012
IKTS Dresden – TU Bergakademie Freiberg, Institut für Keramik, Glas- und Baustofftechnik

Krügel, Holger

Herstellung und Charakterisierung von MSC-Schichtverbunden unter Anwendung papiertechnologischer Streichverfahren
Diploma theses 2012
IKTS Dresden – TU Dresden, Fakultät Maschinenwesen

Lange, Karsten

Mikrowellensynthese von zeolithischen Pulvern und Membranen für die Gastrennung
Bachelor theses 2012
IKTS Dresden – Hochschule Aalen, Studiengang Chemie

Lohrberg, Carolin

Entwicklung LTCC-basierter hochempfindlicher Strömungssensoren
Diploma theses 2012

IKTS Dresden – TU Dresden, Fakultät Elektrotechnik und Informatik, Institut für Feinwerktechnik und Elektronik-Design

Lorenz, Alexander

Untersuchung und Charakterisierung der rheologischen Materialeigenschaften faser- und partikelgefüllter siliziumorganischer Polymere
Diploma theses 2012
IKTS Dresden – TU Dresden, Institut für Leichtbau und Kunststofftechnik

Mathieu, Virgile

Entwicklung, Realisierung und Verifizierung einer Vorrichtung zur ein-

seitigen Einbringung eines Thermochocks in gradierte keramische Mehrlagenlamine
Diploma theses 2012
IKTS Dresden – TU Dresden, Fakultät Maschinenwesen, Institut für Werkstoffwissenschaft

Mennicke, Tobias

Theoretische und experimentelle Untersuchungen zur Stabilisierung technischer Verbrennungsreaktionen in keramischen Schäumen aus Siliziumkarbid
Bachelor theses 2012
IKTS Dresden – HTW Dresden, Fachbereich Maschinenbau/Verfahrenstechnik

Morgenstern, Anne

Verfahrensentwicklung zur Herstellung eines zu charakterisierenden Aluminiumoxid-Direktschaums mit definierter Porenstruktur unter Verwendung unterschiedlich schnell härtender Bindersysteme
Diploma theses 2012
IKTS Dresden – TU Bergakademie Freiberg, Fakultät Maschinenbau, Verfahrens- und Energietechnik

Roszeitis, Sven

Herstellung und Charakterisierung von borreichen Borcarbiden für thermoelektrische Anwendungen
Diploma theses 2012
IKTS Dresden – TU Dresden, Fakultät Maschinenwesen

Swiecinski, Kai

Charakterisierung und Validierung mittels Aerosoldruck hergestellter Widerstände auf Niedertemperatur-Einbrand-Keramiken (LTCC)
Diploma theses 2012
IKTS Dresden – TU Dresden, Fakultät Maschinenwesen

Vogel, Andy

Konstruktion einer Beschichtungsanlage zur Herstellung von gasdichten, asymmetrischen, sauerstoffpermeablen Membranrohren
Master theses 2012
IKTS Hermsdorf – Ernst-Abbe-Fachhochschule Jena, Fachbereich Maschinenbau

Winkler, Matthias

Einsatz von Sinterhilfsmitteln für die Erhöhung der Dichte von asymmetrischen sauerstoffpermeablen Membranen
Bachelor theses 2012
IKTS Hermsdorf – Ernst-Abbe Fachhochschule Jena, Fachbereich Sci-Tec

EVENTS AND TRADE FAIRS 2013

Conferences

Nano- and membrane-based systems for water treatment
April 17–18, 2013, Dresden

ISPA 2013 – International Symposium on Piezocomposite Applications
September 19–20, 2013, Dresden

Biogas Conference
November 11–12, 2013, Dresden

Ceramics Vision
January 16–17, 2014, Dresden

Events

Fraunhofer Talent School
November 15–17, 2013, Dresden
www.talent-school-dresden.de

Seminars/Workshops

DFG-Workshop – Current Topics in Smart Materials and Systems Research
September 18, 2013, Dresden

DKG seminars

Technological fundamentals of granulation and granule processing
April 10–11, 2013, Dresden

Thermoplastic shape-forming of advanced ceramics – technology and training
October 9–10, 2013, Dresden

Debinding of ceramic bodies
October 10–11, 2013, Dresden

Spray drying of ceramic suspensions
November 6–7, 2013, Dresden

Please find further information at www.dkg.de

Seminars of the Fraunhofer AdvanCer Alliance: Introduction into Advanced Ceramics

Part I: Materials, technology
March 6–7, 2013, Dresden

Part II: Machining
May 14–15, 2013, Berlin

Part III: Construction, testing
November 14–15, 2013, Freiburg

For further information please see
www.advancer.fraunhofer.de

Participation in trade fairs

World Future Energy Summit (WFES)
January 15–17, 2013, Abu Dhabi

TerraTec
January 29–31, 2013, Leipzig

Nanotech
January 30–February 1, 2013, Tokyo

FuelCell Expo
February 27–March 1, 2013, Tokyo

INTEC

February 26–March 1, 2013, Leipzig

IDS (Internationale Dentalschau)

March 12–16, 2013, Köln

Jenaer Industry Days

March 17, 2013, Jena

Hannover Messe

April 8–12, 2013, Hannover

SMT/Hybrid/Packaging

April 16–18, 2013, Nürnberg

POWTECH

April 23–25, 2013, Nürnberg

BiogasWorld

April 23–25, 2013, Berlin

Sensor+Test

May 14–16, 2013, Nürnberg

20th Innovationstag Mittelstand

May 16, 2013, Berlin

EuroPM

September 15–18, 2013, Gothenburg

EMO

September 16–21, 2013, Hannover

ISPA

September 19–20, 2013, Dresden

IMAPS 2013

September 29– October 3, 2013, Orlando

EU PVSec 2013

October 1–3, 2013, Paris

Materialica

October 15–17, 2013, München

Productronica

November 12–15, 2013, München

Medica

November 20–23, 2013, Düsseldorf

Hagener Symposium

November 28–29, 2013, Hagen

HOW TO REACH US

How to reach us in Dresden

by car

- At the three-way highway intersection "Dresden West" exit Autobahn A4 onto Autobahn A17 in direction "Prag" (Prague)
- Exit at "Dresden Prohlis" (Exit 4)
- Continue 2 km along the secondary road in direction "Zentrum" (City Center)
- At the end of the secondary road (Kaufmarkt store will be on the right side), go through light and continue straight ahead along Langer Weg in direction "Prohlis" (IHK)
- After 1 km, turn left onto Mügeler Strasse
- Turn right at the next traffic light onto Moränenende
- Continue under the train tracks and turn left at next traffic light onto Breitscheidstrasse
- Continue 3 km (the road name will change to An der Rennbahn and then to Winterbergstrasse)
- Fraunhofer IKTS is on the left side of the road (Winterbergstrasse 28)

by train

- From Dresden main station take train S1 (direction Bad Schandau) or train S2 (direction Pirna) to stop "Haltepunkt Strehlen"
- Change to bus line 61 (direction Weißig/Fernsehturm) or 85 (direction Striesen) and exit at "Grunaer Weg"

by plane

- From Airport Dresden-Klotzsche take a taxi to Winterbergstrasse 28 (distance is approximately 7 miles or 10 km)
- Or use suburban train S2 (underground train station) to stop "Haltepunkt Strehlen"

How to reach us in Hermsdorf

by car

- From exit Bad Klosterlausnitz/Hermsdorf (A9, exit 23) follow the road to Hermsdorf, go straight ahead up to the roundabout
- Turn right to Robert-Friese-Strasse
- The 4th turning to the right after the roundabout is Michael-Faraday-Strasse
- Fraunhofer IKTS is on the left side
- From exit Hermsdorf-Ost (A4, exit 56a) follow the road to Hermsdorf
- At Regensburger Strasse turn left and go straight ahead up to the roundabout
- Turn off to right at the roundabout and follow Am Globus
- After about 1km turn off left to Michael-Faraday-Strasse
- Fraunhofer IKTS is on the left side

by train

- From Hermsdorf-Klosterlausnitz main station turn right and walk in the direction of the railway bridge
- Walk straight into Keramikerstrasse (do not cross the bridge)
- Pass the porcelain factory and the Hermsdorf town house
- Turn right, pass the roundabout and walk straight into Robert-Friese-Strasse
- After 600 m turn right into Michael-Faraday-Strasse
- Find Fraunhofer IKTS after 20 m

Editorial team/layout

Katrin Schwarz
 Peter Peuker
 Susanne Freund
 Annika Ballin
 Rita Kunath

Printing

ELBTAL Druckerei & Kartonagen Kahle GmbH

Photo acknowledgments

Atelier "Mein Foto" Dresden
 Foto Wachs, Dresden
 Photographer Jürgen Lösel, Dresden
 Photographer Sebastian Reuter, Jena
 fotoline studio, Dresden
 Fraunhofer IKTS
 MEV Verlag

Institute address

**Fraunhofer Institute for
 Ceramic Technologies and Systems IKTS**

Dresden branch of the institute
 Winterbergstrasse 28, 01277 Dresden, Germany
 Phone +49 351 2553-7700
 Fax +49 351 2553-7600

Hermsdorf branch of the institute
 Michael-Faraday-Strasse 1, 07629 Hermsdorf, Germany
 Phone +49 36601 9301-0
 Fax +49 36601 9301-3921

info@ikts.fraunhofer.de
 www.ikts.fraunhofer.de

Press and public relations

Dipl.-Chem. Katrin Schwarz

Phone +49 351 2553-7720
 katrin.schwarz@ikts.fraunhofer.de

Reproduction of any material requires the editors' consent.

© Fraunhofer IKTS, Dresden 06/2013